

MACHINE LEARNING IN TODAY'S SCENARIO AND THE OPPORTUNITIES
CAC2223 - MACHINE LEARNING TECHNIQUES
FIELD VISIT REPORT TO



Staff Coordinators: Mr. V.M. Niaz Ahamed and Mr. Rizwam Alam/CA

Date 19.09.2018

Number of Students Visited: 245



The details of students participated in the Industrial visit are

S.No.	RRN	Name of the student
1	181371601001	ABDUL NAZER J
2	181371601002	ABDUL RAHAMAN M
3	181371601003	ABITHA BANU A
4	181371601004	ABRAR AHAMED A
5	181371601005	ABU RRUHEL M
6	181371601006	ABUBAKKAR SIDDIK S
7	181371601007	ARUL SURESH G A
8	181371601008	ASHWIN G
9	181371601009	BHAKIYA LAKSHMI B
10	181371601010	BHARNIDHARAN R
11	181371601011	CHANDRASEKAR V
12	181371601012	CHATURVEDIKA A
13	181371601013	DARSHAN K
14	181371601014	DINESH KUMAR V
15	181371601015	DINESH J P
16	181371601016	FARHAN A
17	181371601017	FARITH A FATHIMA L
18	181371601018	FAROOK ABDUL AZIZ A
19	181371601019	Ganesh.K
20	181371601020	GIRIDHARAN R
21	181371601021	HARISH R
22	181371601022	INDRAPRIYADHARSHINI K
23	181371601023	ISHAK S
24	181371601024	JAYASHRUTHI G
25	181371601025	JOHN ARUL W
26	181371601026	JOTHIKA L
27	181371601027	KARAN S
28	181371601076	KARTHICK.S
29	181371601028	KAVITHA V
30	181371601029	LEZAN AHAMED H
31	181371601030	MANAZIR AHSAN J
32	181371601031	MANIKANDAN M
33	181371601032	MANOJ P
34	181371601038	MD SHEIK ZUBAIR HUSSAIN K
35	181371601033	MOHAMED HASAN A
36	181371601034	MOHAMED IBRAHIM S
37	181371601035	MOHAMED KAMIL Y
38	181371601036	MOHAMED RIYAS A
39	181371601037	SHAHUL HAMEED S.M.B
40	181371601039	MOHAMED SAKEEL M
41	181371601040	MOHAMED WASEEM M
42	181371601041	MOHAMMED RIYAS A

43	181371601042	MOHAMMED AFZAL M
44	181371601043	MOHAMMED FARAZ KHAN
45	181371601044	MOHAMMED RIYAS M
46	181371601045	MOHAMMED YUSUF M
47	181371601046	MUBEEN M
48	181371601047	MUKESH B
49	181371601048	MUKESH V
50	181371601049	MUTHUKUMAR S
51	181371601050	NAGALAKSHMI N
52	181371601051	NANDHINI S
53	181371601052	NEVATHITHA K
54	181371601053	NITHISH JAISANKAR J
55	181371601054	POORNIMA S
56	181371601055	PRAKASH R
57	181371601056	PRINCE JACOB D
58	181371601057	RANJITH KUMAR R
59	181371601058	RANJITHA R
60	181371601059	RIZWAN A
61	181371601060	ROHITH A V B
62	181371601061	SAI PRASHANTH H
63	181371601062	SANDHIYA K
64	181371601063	SHARMILA V
65	181371601064	SNEHA S
66	181371601065	SRISURIYA A
67	181371601066	SUDHA P
68	181371601067	SURENDER S
69	181371601068	THASLEEM S
70	181371601069	THASNEEM A
71	181371601070	UMAR FAROOK Y
72	181371601071	UPPLISREENEVAS V
73	181371601072	VELPRABAKAR P
74	181371601073	VIJAYAKUMAR R
75	181371601074	VIMAL V
76	181371601075	YASMIN R
77	181421601001	AAKASH R
78	181421601002	ABHISHEK J
79	181421601003	AHMED ZEESHAN FAZAL
80	181421601004	ANISH A
81	181421601005	ARAVINDH S
82	181421601006	ARBAZ SIDDIQUI
83	181421601043	ASIF AHAMED
84	181421601007	ASIF SHERIFF A
85	181421601008	ASTLE JOSPHAT A
86	181421601009	BHARATH KUMAR M
87	181421601010	DEEPIKA A
88	181421601011	DINESH R

89	181421601012	EDWIN VICTOR J
90	181421601013	GOKUL D
91	181421601014	HABEEB RILWAN R
92	181421601015	HUDAFIA FABIN S S
93	181421601016	ILAKIYA K
94	181421601017	INZAMAM ULHAQ S
95	181421601018	JEEVA S
96	181421601019	JISHNU S
97	181421601020	JOTHILAKSHMI L
98	181421601021	KARTHICK R
99	181421601022	KIRTHIGA M H
100	181421601023	LATHA K
101	181421601024	MAGESH BAGYARAJ R
102	181421601025	MISHALIN M
103	181421601026	MOHAMED FAZIL T
104	181421601027	MOHAMED SAJITH S
105	181421601028	MOHAMED YASINAFSAR M
106	181421601029	MOHANRAJ S
107	181421601030	MOHAMMAD RAIYAN A
108	181421601031	NANDHA KISHORE A
109	181421601032	NAVEEN T
110	181421601033	PRIYANKA G
111	181421601034	RAMKUMAR A
112	181421601035	SACHIN
113	181421601036	SALMAN KHAN S
114	181421601037	SANTHOSH G
115	181421601038	SHABANA BEGUM A
116	181421601039	SHAHITH KHAN E
117	181421601040	SHRIKADHIR K
118	181421601041	SURENDAR V
119	181421601042	TONY PRASANTH L
120	181361601001	ABDUL SUBHAN G
121	181361601002	AJANSHA S
122	181361601003	DANNY NORMAN N
123	181361601004	DEEPAI SAI V
124	181361601005	DEEPAN B
125	181361601006	HIQUMATHULLA S
126	181361601007	KALAISELVAN P
127	181361601008	MANOJ KUMAR V
128	181361601009	MOHAMED JAMEER SHAHITH V
129	181361601010	MOHAMED NOORUL MUBEEN N A
130	181361601011	MOHAMED RIZWAN
131	181361601012	MOHD. SADAKATHULLAH MUJAHIR M
132	181361601013	MOHAMMED ABUBAKKAR SIDDIQ S
133	181361601014	MOHAMMED ASHIK S
134	181361601016	MUHAMMAD MAHASUQ S

135	181361601017	NIVAS AHAMED N
136	181361601020	SAIFUDEEN AHAMED
137	181361601021	SATHISH KUMAR J
138	181361601024	THAMIMUL ANSARI P
139	181361601025	THANVEER NAWAZ S
140	181361601029	VENKATESH.S
141	181361601026	WASIM AFSER A
142	181361601027	WISWA M
143	181361601028	YOKESH R
144	181351601001	ABINESH. M
145	181351601002	AFNAN SHAKEEL
146	181351601003	AHAMED IMAM. A
147	181351601004	AJAY KUMAR. B
148	181351601005	AJESH. T
149	181351601006	AKSHAY. K
150	181351601007	ANWAR AFRIDI. Y
151	181351601008	ARUNA. A
152	181351601009	ASHREETHA. U
153	181351601010	ASHWINI. S
154	181351601011	BAESIL SHOWCATH
155	181351601012	BALAJI. D
156	181351601013	BALAMURALI KRISHNA. D
157	181351601014	BHUVANESHWARAN. R.P
158	181351601015	DEVESH RAJ. M
159	181351601016	DHANIYAVEL. B
160	181351601017	DHANUSH. D
161	181351601018	DHASEELAN. S
162	181351601019	DHIYANESHWARAN. S
163	181351601020	DIBHISHA. A
164	181351601021	DURGA. M
165	181351601022	ELANGO VAN. R
166	181351601023	FAHD SYED NAINA
167	181351601024	FAYIZA MARZOOKA. T.F
168	181351601025	FEHMAN HARIS. K
169	181351601026	FEROZ KHAN. M
170	181351601027	GERALD NETHANIEL. F
171	181351601028	HABEEB MOHAMMED BADHUSHA
172	181351601029	HAMEEDUL MAS. H
173	181351601030	HARIHARAN. M
174	181351601032	IJAZ AHAMED. A
175	181351601033	INIYAVAN. M
176	181351601034	JAGADESH
177	181351601035	JITISH KUMAR. B
178	181351601036	KARTHICK
179	181351601037	KARTHIKRAJAN. S
180	181351601038	KIRAN KRISHN. G

181	181351601039	KIRUBHA. S
182	181351601040	KIRUTHIKA. R
183	181351601041	KRITHIVASAN. R
184	181351601042	LOKESH. S
185	181351601044	MAHESHWARAN. V
186	181351601045	MEENAKSHI.S
187	181351601046	MOHAMED BATCHA M
188	181351601047	MOHAMED FARIZ. M.R
189	181351601048	MOHAMED IBRAMSHA. A
190	181351601049	MOHAMMED ISMAIL FAZIL. K.J
191	181351601099	MOHAMED NADEEM
192	181351601101	DEEPIKA
193	181351601103	MOHAMED SAJITH S
194	181351601105	SUBIKSHA PUSHANAM
195	181351601106	ASHWIN THOMAS
196	181351601110	GOWTHAM
197	181351601050	MOHAMED JAFIR ABDEEN. T.A
198	181351601051	MOHAMED MUBARAK
199	181351601052	MOHAMED SAHIR. J
200	181351601053	MOHAMED SALMAN SHA. A
201	181351601054	MOHAMED SHAHEED. A
202	181351601055	MOHAMMED ABDUL MULTHASEEM. S
203	181351601056	MOHAMMED ANAS. A
204	181351601057	MOHAMMED DANISH. M
205	181351601058	MOHAMMED MUSHRAF. Y
206	181351601059	MOHANARAMAN.P.A
207	181351601060	MUJAMIL. S
208	181351601061	NAZEEM NOOR
209	181351601062	POOJA SRI. S
210	181351601063	PRASANTH. S
211	181351601064	PRAVINNKUMAR. E
212	181351601065	RAAGHAVENDRAN. J
213	181351601066	RAFEEKA. S
214	181351601067	RAHUL.C
215	181351601068	RAJESH KUMAR. B
216	181351601069	RAVEEN.P
217	181351601070	RICHARD. D
218	181351601071	SAI CHARAN.P.R
219	181351601072	SAIFUDEEN. N
220	181351601073	SAKTHIVEL VARMA. S.R
221	181351601074	SAMEENA. A
222	181351601075	SARANYA. M
223	181351601076	SARAVANA. D
224	181351601077	SHAALINI. S
225	181351601078	SHAHA BUDEEN. A
226	181351601079	SHAIFUL ISLAM A

227	181351601080	SHALINI. U
228	181351601081	SRIJA SIVAKUMAR
229	181351601082	SRIRAM. S
230	181351601083	STEPHEN RAJ.M
231	181351601084	SWATHI K V
232	181351601085	SWATHY. G
233	181351601086	SYED ASIF. G
234	181351601087	SYED AFTHAB AHAMED. A
235	181351601088	THAMEEMUL ANSARI. R
236	181351601089	THARUN. C
237	181351601090	THARUNVARSHAN. R.K
238	181351601091	THONDREESWARAN. S
239	181351601092	VIGNESH. R
240	181351601093	VIGNESHWAR. S
241	181351601094	VISHAL. J
242	181351601095	VISHAL. R
243	181351601096	VISWA. V
244	181351601097	YOGESHWARAN. K
245	181351601098	YUKESH. U

Preamble:

This report exhibits about Project based Learning on Machine Learning Techniques. Students of I-B.Sc (Computer Science), I-BCA (Data Science), I-BCA (Mobile Applications & Information Security) and I-BCA (Cloud & Information Security) have visited to Caddam Technologies Pvt. Ltd., to know about future prospects in Machine Learning. A demonstration was given to the students on the Machine Learning applications in various fields.

Caddam Technologies Pvt. Limited is located in Ekkatuthangal, Chennai. The objective of this visit is to understand the impact of Machine Learning in today's scenario and the opportunities available in this field visit. The students were given an overview about the tools that are required for Machine Learning. They insisted on the statistical knowledge required to perform the analysis. They have briefed on the applications of Machine learning in various field. They focused on the use of machine learning techniques for image classification, pattern recognition and data science in computer applications. It also focused on mathematical techniques and enlightened the knowledge in developing many complex applications.

Machine Learning is one of the essential fundamentals required to step into the rapidly emerging and upcoming era of Artificial Intelligence (AI). Data processing

requires “COMPUTATIONAL THINKING” and is essential to have hands-on experience in using computational tools for problem-solving. This visit has explored the recent development and various machine learning and deep learning based security approaches in the field of cyber security. This visit will be an 'eye-opener' to build the computational skills required for machine learning.

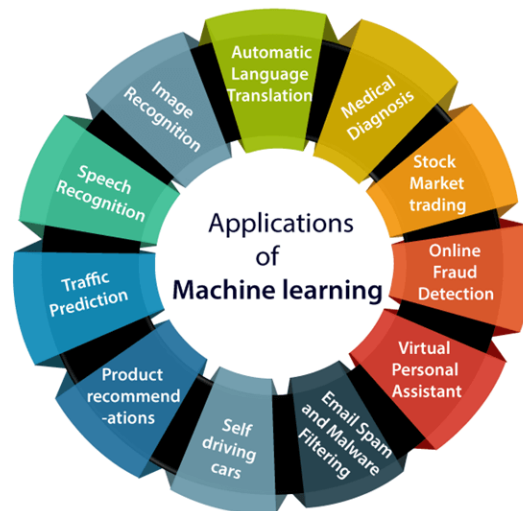

Fig: Applications of Machine Learning

This visit gave an exposure on the fundamental and advanced machine learning concepts in the field of image processing and motivated the students to involve in research and use machine learning techniques to improve the learning process.

Outcome of the Industrial Visit

- Exposure to industry atmosphere.
- Gained knowledge about the opportunities in the field of Machine Learning.
- Experienced about the latest techniques in Machine Learning.
- Provided a guideline for the students to pursue their project in this area.

Staff Coordinator

Mr.V.M.Niaz Ahamed

Mr.Rizwan Alam

A. Jaya
HOD/CA 20/9/18

Dr. A.JAYA, M.C.A.M.E,Ph.D
Professor & Head
Department of Computer Applications
B.S. Abdur Rahman Crescent Institute of
Science and Technology
Chennai - 600 048

ACCELERATING DIGITAL TRANSFORMATION - INTERNET OF THINGS

CAD7203- ADVANCED TECHNOLOGIES

INDUSTRIAL VISIT TO



Staff Coordinator: Dr. Shahar Banu and Ms. Shahtaj/CA

Date 20.8.2018

Number of Students Visited: 123



The details of students participated in the Industrial visit are

S.NO.	RRN	NAME OF THE STUDENT
1	181371601001	ABDUL NAZER J
2	181371601002	ABDUL RAHAMAN M
3	181371601003	ABITHA BANU A
4	181371601004	ABRAR AHAMED A
5	181371601005	ABU RRUHEL M
6	181371601006	ABUBAKKAR SIDDIK S
7	181371601007	ARUL SURESH G A
8	181371601008	ASHWIN G
9	181371601009	BHAKIYA LAKSHMI B
10	181371601010	BHARNIDHARAN R
11	181371601011	CHANDRASEKAR V
12	181371601012	CHATURVEDIKA A
13	181371601013	DARSHAN K
14	181371601014	DINESH KUMAR V
15	181371601015	DINESH J P
16	181371601016	FARHAN A
17	181371601017	FARITH A FATHIMA L
18	181371601018	FAROOK ABDUL AZIZ A
19	181371601019	GANESH.K
20	181371601020	GIRIDHARAN R
21	181371601021	HARISH R
22	181371601022	INDRAPRIYADHARSHINI K
23	181371601023	ISHAK S
24	181371601024	JAYASHRUTHI G
25	181371601025	JOHN ARUL W
26	181371601026	JOTHIKA L
27	181371601027	KARAN S
28	181371601076	KARTHICK.S
29	181371601028	KAVITHA V
30	181371601029	LEZAN AHAMED H

31	181371601030	MANAZIR AHSAN J
32	181371601031	MANIKANDAN M
33	181371601032	MANOJ P
34	181371601038	MD SHEIK ZUBAIR HUSSAIN K
35	181371601033	MOHAMED HASAN A
36	181371601034	MOHAMED IBRAHIM S
37	181371601035	MOHAMED KAMIL Y
38	181371601036	MOHAMED RIYAS A
39	181371601037	SHAHUL HAMEED S.M.B
40	181371601040	MOHAMED WASEEM M
41	181371601041	MOHAMMED RIYAS A
42	181371601042	MOHAMMED AFZAL M
43	181371601043	MOHAMMED FARAZ KHAN
44	181371601044	MOHAMMED RIYAS M
45	181371601045	MOHAMMED YUSUF M
46	181371601046	MUBEEN M
47	181371601047	MUKESH B
48	181371601048	MUKESH V
49	181371601049	MUTHUKUMAR S
50	181371601050	NAGALAKSHMI N
51	181371601051	NANDHINI S
52	181371601052	NEVATHITHA K
53	181371601053	NITHISH JAISANKAR J
54	181371601054	POORNIMA S
55	181371601055	PRAKASH R
56	181371601056	PRINCE JACOB D
57	181371601057	RANJITH KUMAR R
58	181371601058	RANJITHA R
59	181371601059	RIZWAN A
60	181371601060	ROHITH A V B
61	181371601061	SAI PRASHANTH H
62	181371601062	SANDHIYA K
63	181371601063	SHARMILA V
64	181371601064	SNEHA S

65	181371601065	SRISURIYA A
66	181371601066	SUDHA P
67	181371601067	SURENDER S
68	181371601068	THASLEEM S
69	181371601069	THASNEEM A
70	181371601070	UMAR FAROOK Y
71	181371601071	UPPLISREENEVAS V
72	181371601072	VELPRABAKAR P
73	181371601073	VIJAYAKUMAR R
74	181371601074	VIMAL V
75	181371601075	YASMIN R
76	171371601001	ABDUL RAVOOF M A K
77	171371601002	ABUBAKKAR SIDDIQ J
78	171371601003	ANGEETHA M
79	171371601005	AVINESH R
80	171371601007	DIVYA.U
81	171371601008	GOWTHAM R
82	171371601009	HARIHARAN R
83	171371601010	HARIHARAN S N
84	171371601011	HARIHARAN.G
85	171371601012	HARISHKUMAR T
86	171371601013	HYQA FAZAL FACTOO
87	171371601014	JANANI H.
88	171371601015	JOEL R
89	171371601016	KAMAL RAJENDRAN
90	171371601017	KARTHIKEYAN M
91	171371601018	KRISLYN FELECIA XAVIER
92	171371601019	LEKHASRI. B
93	171371601020	MADHU PRITHAA V B
94	171371601021	MANOJ KUMAR H.
95	171371601022	MOHAMAD BASITH.M
96	171371601023	MOHAMED NASIR K
97	171371601024	MOHAMMED IRFAN P
98	171371601025	MOHAMMED NADEEM KHAN.N

99	171371601026	PRIYADHARSHINI R
100	171371601027	RAGHUL SANJAY. S
101	171371601029	SAMEERA M
102	171371601030	SARFARAAZ AHAMED S
103	171371601031	STEPHEN F
104	171371601033	SYED AKRAM R
105	171371601034	UMER S.
106	171371601035	VIGNESH A
107	171371601036	VISHAAL. S
108	171371601037	VISHWAJITH V
109	171371601038	AFRUL RAHMAN.J
110	171371601039	MOHAMMED ABDULLAH H.K
111	161371601001	ABINASH J
112	161371601003	FAHED
113	161371601004	HARIKRISHNAN M
114	161371601005	JAYARAJ S
115	161371601006	KARTHICK R
116	161371601007	MARZOOK HASAN R
117	161371601010	SHEIK MOHAMMED S
118	161371601011	SALMAN KHAN A M
119	161371601012	SHARUKHAN S
120	161371601013	SUSMITHA KANIMOZHI S
121	161371601016	MOHAMMED FAZIL MAIDEEN S
122	161371601017	MUGILAN
123	161371601018	SALIM MALIK H

Preamble

An industrial visit to Technosoft Corporation, scheduled for B.Sc. Computer Science students of Computer Application department with respect to their course “ADVANCED TECHNOLOGIES” to provide more depth knowledge on course and hands on experience from industry persons on 20/08/18. A total of 123 students attended the visit. Technosoft’s global team delivers custom high tech solutions to clients all over the world.

Internet of Things is all about change the things in your world. IoT devices can improve the quality of life for citizens of smart cities in many ways, whether the devices save lives, manage noise pollution or decrease response time to natural disasters. The sensors could be used for situations such as traffic management or public safety. Their digital and engineering architects help our clients shift from pilot solutions to production at enterprise scale. They explained about their companies developing strategy and approach to implement integrated digital initiatives and ecosystems that deliver value at every step.

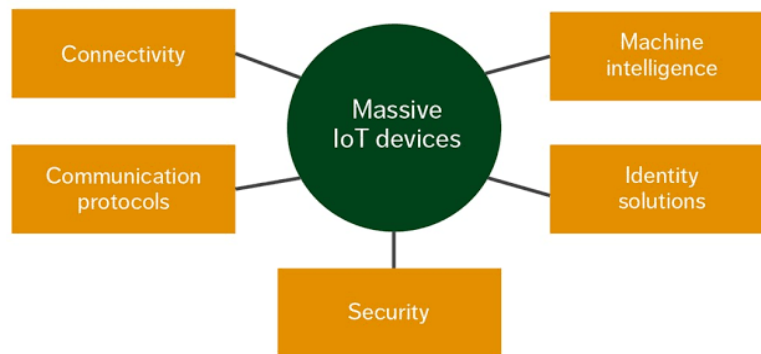

Fig: IoT devices

The students were given a lecture on Numerous IoT research and application projects have been done by universities or in joint industry-university consortia in recent years. IoT applications in the sense of this industry workshop are solutions using IoT technologies to improve industrial manufacturing processes, enable new and efficient ways to do operate production plants, create new service or supervision means for industrial installations, offer an optimized infrastructure, reduce operational cost or improve human safety in industrial areas. From an industry point of view value creation form IoT applications and sustainability are essential. How these problems will be addressed and solved will influence the use of IoT technologies in the industry, on a larger scale, in the coming years. This visit made the students to kindle and stimulate ideas.



Fig: During Technical Session

Outcome of the Industrial Visit

- Students learned much practical application
- Gained knowledge about the opportunities in the field of IoT.
- Experienced about the latest techniques in IoT.

Staff Coordinator

Dr. Shahar Banu

Ms. Shahta

A. Jaya
22/8/18

HOD/CA

Dr. A.JAYA, M.C.A, M.E, Ph.D
Professor & Head
Department of Computer Applications
B.S. Abdur Rahman Crescent Institute of
Science and Technology
Chennai - 600 048

INSIGHT TO ANIMATIONS

CAD6201 - COMPUTER GRAPHICS AND MULTIMEDIA SYSTEMS

Report on Field Visit to Maya Academy of Advanced Cinematics

Staff Coordinators: Mr. A. Salman Ayaz and Mr. V.M. Niaz Ahamed/CA

Date: 14-2-2019

No. of Students Participated:105



I. Preamble

An industrial visit to Maya Academy of Advanced Cinematics was scheduled on 14-02-2019, for MCA students with respect to the course to “**Computer Graphics and Multimedia Systems**”. The main reason behind this is to provide more depth knowledge on course and hands on experience from industry persons. It allows the students to know things practically through interaction, working methods and employment practice. Moreover it gives exposure from academic point of view. It also provides a good opportunity to the students to gain full awareness about industrial practices. Through these visits students got awareness about new technologies in the android development field. After visiting an industry, students can get a combined knowledge of both theory and practical. They were able to understand how images, words, symbols, and letters can be used as effective means of communication and portray the right message to the right audience at the right time. The students were given a practical implementation of the six animation techniques that they use in their real time projects. They have given an insight into five different types of animation.

II. About the Visit

On 14.2.2019 students of III MCA Section A and B (105 nos) with two faculty members visited MAAC Academy, Guduvancherry. The following are the list of students participated in the Industrial visit. Mr. A. Salman Ayaz and Mr. V.M. Niaz Ahamed, Assistant Professor, Dept. of CA, accompanied the students during the industrial visit.

S.No.	Reg No	Name
1	160282602001	ABDUL MALIK. H
2	160282602002	ABDUL MOHAMMED. J
3	160282602003	ABUBACKER SIDDIQUE. M

4	160282602004	AHAMED MOITHEEN FAYAZ. T
5	160282602005	AHMED MUSTHAFA. A
6	160282602006	AJMALBASA. B
7	160282602007	ALRASHITH. N
8	160282602008	MD AMIR SOHAIL. K
9	160282602009	ANITHA. A
10	160282602010	ASHA BURJANA. S
11	160282602011	ASHWINI. K
12	160282602012	BALAJI. R.S
13	160282602013	BHAKYALAKSHMI. B
14	160282602014	DEEPIKA. P
15	160282602015	DIVYA. S
16	160282602016	ESTHER. J
17	160282602017	FAZALULLA. A
18	160282602018	FIRDHOS. A
19	160282602019	FOUSIYA BEGUM. A
20	160282602020	GAAYATHRE. K.S
21	160282602021	GOPI. K
22	160282602022	GOPI KRISHNAN. R
23	160282602023	HAARIS EGHBAL
24	160282602024	HUSNA KOUSER. A
25	160282602025	ILYAS HUSSAIN
26	160282602026	IMRAN BASHA. K.A
27	160282602027	ISHVARYA. S
28	160282602028	JAHABER SHAIK ALLAVUDEEN. M.I
29	160282602029	JALALUDEEN. M
30	160282602030	JAYASHREE. S
31	160282602031	JISHA. L.S
32	160282602032	KALYANI. J
33	160282602033	KEERTHANA. S
34	160282602034	KHAJA HUSSAIN AHAMED. A
35	160282602035	KIRUBA SANKAR. R
36	160282602036	LALITHA LAKSHMI. P
37	160282602037	LAVANYA. S

38	160282602038	LAVANYA. S
39	160282602039	LIYAKATH ALI. W
40	160282602040	MATHESWARAN. E
41	160282602041	MATHIVANAN. S
42	160282602042	MD ASGHAR. A
43	160282602043	MEERA. J
44	160282602044	MOHAMED ABDUL HAMEED. I
45	160282602045	MOHAMED ABDUL HUSSAIN. A
46	160282602046	MOHAMED FAIROJUDEEN. M
47	160282602047	MOHAMEDFASIL. J
48	160282602048	MOHAMEDHAJAIFTHIKARUDEEN. S
49	160282602049	MOHAMED NOWSATH ALI. Z.A
50	160282602050	MOHAMED RIZWAN. S
51	160282602051	MOHAMED SHAKEEL. A
52	160282602052	MOHAMED UDHUMAN. A.K
53	160282602053	MOHAMMED ASLAM. A
54	160282602055	MOHAMMED KASHIF.B
55	160282602056	MURALI. R
56	160282602057	NANDHINI. K
57	160282602058	NAVEEN KUMAR. V
58	160282602059	NIKITHA. N
59	160282602061	NIVETHA. M
60	160282602062	PAVEETHIRA. S
61	160282602063	PRABHAKAR. S
62	160282602064	PRABHURAM. K.R
63	160282602065	PRATHIKSHA. S.V
64	160282602066	PREETHI. N
65	160282602067	PRIYANKA. S
66	160282602068	PUGAZH MANI. B.S
67	160282602069	RAGA SUDHA. M
68	160282602070	RAJALAKSHMI. D
69	160282602071	RAMYA. B
70	160282602072	RESHMA. R
71	160282602073	ROKITH RAJ. P

72	160282602074	SABARISH. R.N
73	160282602075	SALIM KHAN. F
74	160282602076	SAMIUDEEN. S
75	160282602077	SANJAI. L.E
76	160282602078	SANJAY KANNAN. P
77	160282602079	SARDAR HAMEEDULLAH. R
78	160282602080	SARFARAZ. A
79	160282602081	SHAIK NAINA MARICAR. K
80	160282602082	SHAMSUDHEEN. S
81	160282602083	SHARAN. M
82	160282602084	SHEREEN PARVIN. S
83	160282602085	SIVA SANKARI. G
84	160282602086	SRINIVASAN@SHANMUGAVEL
85	160282602087	SRUTHI. R
86	160282602088	SUDHARSANA RAGHAVAN. S.R
87	160282602089	SWATHI PRIYA. R
88	160282602090	SYED ABOOTHAHIR. M
89	160282602091	SYED IRBAS AHMED. K
90	160282602092	SYED RAAVIYA. S
91	160282602093	SYED SHAKIR. Y
92	160282602094	TAMILSELVI. S
93	160282602095	TARIQ AHMED. R
94	160282602096	THANGA PANDIYAN. R
95	160282602097	THANVEER AHAMED. A
96	160282602098	THARIQ MOHAMED. A
97	160282602099	VENKATARAMANA. B
98	160282602100	VIGNESH. R
99	160282602101	VIGNESHWARAN. E
100	160282602102	VIGNESHWARI G
101	160282602103	VIVEKANANDAN. A.N
102	160282602104	YUVADHARANI. S
103	160282602105	YUVARAJ. V
104	160282602106	ALI BASHA. K
105	160282602107	MUSHARIF IMRAN. A



Fig: MAAC staff delivering the contents of animation

The objective of the visit is to understand about Apps are developed and to combine the theoretical knowledge with practical exposure through field observation, inquiry and submission of relevant report. Students were able to grasp the various intricacies involved in app development. The key file storage and interchange formats and Application Programming Interface (APIs) to multimedia devices.



Fig: Students Interaction with the MAAC Staff

Outcome of the Industrial Visit

- Fantastic experience to industrial atmosphere
- Able to familiarize with the way an application is developed
- Able to comprehend the ways in which apps can be delivered using various technologies.

Staff Coordinator

A. Jaya
15/2/19
HOD/CA

Dr. A. JAYA, M.C.A, M.E, Ph.D
Professor & Head
Department of Computer Applications
B.S. Abdur Rahman Crescent Institute of
Science and Technology
-Chennai - 600 048

**INDUSTRIAL VISIT PROJECT REPORT ON
“TOXICOLOGY STUDIES & ANIMAL HANDLING AND
ANIMAL MODELS FOR DISEASES ”**

**Visited to Bioresearch Foundation, Sengadu Village & Post, Via
Manavala Nagar, Sriperumpudur, Chennai, Tamil Nadu**

BTB2106 Basic Bioanalytical Techniques

**Course Content: Module1 -6: Calorimetry, Spectroscopy, Centrifugation and
electrophoresis**

BTB 2213 Animal Biotechnology

Course Content: Module 5 : Transgenic animals

Faculty coordinator: Dr. Shazia Jamal(Assistant Professor)

Dr. Vimal Kumar (Assistant Professor)

Dr. Faridha Begum (Scientific Assistant)

**Class: (B.Tech 2nd , 4th SEM students and M.Sc, M.Tech (IV
Semester) Students); No. of Students: 220**



Preamble: An industrial visit to “Bioresearch Foundation, Manavala Nagar, Sriperumpudur, Chennai, Tamil Nadu was organised by the school of Life Sciences on 26.09.2018 & 27.09.2018 (Wednesday & Thursday). Two hundred and twenty students of B.Tech 2nd, 4th SEM students and M.Sc, M.Tech (IV Semester) Students with three coordinators namely Dr. Shazia Jamal Dr. Vimal Kumar and Dr. Faridha Begum visited the lab. In this visit students learned bioanalytical techniques, toxicological analysis and animal models and handling.

Salient features: Bioscience Research Foundation (BRF) is an integrated discovery and developing Contract Research Organization (CRO). BRF, situated near Sriperumpudur, Chennai, Tamil Nadu, India. BRF was established to promote scientific research through biotechnology, with specific emphasis on agrochemicals, pharmaceuticals, health care and other industrial chemicals including bio-inputs and to facilitate the extension of knowledge in the field of regulatory affairs and Bioscience, especially for contract research.

Bioscience Research Foundation (BRF) is a eco-friendly test facility with modern equipped analytical instruments along with programmes planned and carried out under five broad categories, Such as

Agrochemicals,

Pharmaceutical products,

Veterinary drugs,

Industrial Chemicals,

Food and feed additives.

BRF focused to enthrall in chemistry, toxicology, genetic toxicology, ecotoxicology, entomology, pathology, and animal breeding (Big animal house)





DETAILS OF THE STUDENTS PARTICIPATED

B. Tech Biotechnology (IV SEM A Section)

S. No	RRN Number	Name of the student
1	160151601002	ABERNA S
2	160151601003	AHAMED ATHEEF N A
3	160151601004	ANITHA S
4	160151601005	ANUPAMA V
5	160151601006	ARSHIYA A
6	160151601007	ARUN KUMAR T C
7	160151601008	ASHWIN K
8	160151601009	ASLAM AHMED.M.S.
9	160151601010	AYESHA SIDDIQUA K
10	160151601012	AYISHA MUNAWWARAH
11	160151601013	BARAKATHUNISA H
12	160151601014	DEEPAK A

13	160151601015	DEEPIKA A H
14	160151601016	DEVADARSINI T
15	160151601017	DINESH B
16	160151601018	DINESH P R
17	160151601019	FAIZA FATHIMA A S
18	160151601020	FARHEEN N
19	160151601021	FATHIMA N I
20	160151601022	GAYATHRI M
21	160151601023	GOKUL NAINAR S
22	160151601025	HAJEERA BANU A
23	160151601026	HASEENA BEGUM P
24	160151601027	HAWAMA M
25	160151601028	HIKHMATHUNNISA S N
26	160151601029	ILAKKIYA R
27	160151601030	ILAYABHARATHI V
28	160151601031	JAINUL AFRIN ASHIKA K
29	160151601032	JANNET REFONA J K
30	160151601033	JAYASHREE B
31	160151601034	JENISHA BEGAM.H
32	160151601035	KASHIFA FATHIMA J
33	160151601036	KIRANBABU R
34	160151601037	KIRUBHA SANKAR S
35	160151601038	KRITHIKA.V.

36	160151601039	MANCY A
37	160151601040	MARWAN S M

B. Tech Biotechnology (IV SEM B Section)

S. No	RRN Number	Name of the student
1	1600151601041	MOHAMED DHARWISH M
2	1600151601042	MOHAMED SYED SHAIK ISMAIL G
3	1600151601043	MOHAMMED SHAJIUDDIN
4	1600151601044	MOHSEEN FATHIMA S
5	1600151601045	NAIFA JAMEEL K
6	1600151601046	NARENDRAN R
7	1600151601047	NAZIYA SAYEED H
8	1600151601048	NIKITHA SHERIN NISAR
9	1600151601049	NISHA K
10	1600151601050	NIVEDITA V
11	1600151601051	POOJA P A
12	1600151601052	PRADEEP PARTHASARATHY M
13	1600151601053	RAMEEZA BANU S
14	1600151601054	RISHIVANTH S
15	1600151601056	RUKAIYA HASANI KHASAMWALA
16	1600151601057	SAFIYA HUSSAIN
17	1600151601058	SAMRIN ABDUL SATHAR
18	1600151601059	SEDHA MAMTHA V
19	1600151601060	SELVARAJ MUKESH
20	1600151601061	SEVENTHI S
21	1600151601063	SHANAZ SALMA J
22	1600151601064	SHRIRAM S

23	1600151601065	SONIYA A
24	1600151601067	SRIRAM B
25	1600151601068	SYED ASFAR LATHIF S
26	1600151601069	SYED FAHAD S
27	1600151601070	THARANI P
28	1600151601071	UMME KULSUM. R.
29	1600151601072	VAANI A C
30	1600151601073	VINODHINI C
31	1600151601075	Akshaya T
32	1600151601076	ANGEL SHARON P.
33	1600151601078	ROSHINI P
34	1600151601080	RAMYAKRISHNAN R
35	1600151601081	MAHALAKSHMI M
36	1600151601085	SHAHARIYAR K.M

B.Tech Biotechnology (II SEM, A, B, C sections)

1	160151601059	Sedha Mamtha V
2	160151601088	Mohamed Asif Salman S
3	170151601001	Aadil Sharjath Aalam K F
4	170151601003	Abdul Haseeb I
5	170151601004	Abdul Kalam A
6	170151601005	Abdul Matheen
7	170151601006	Abdullah Naveed Khan A
8	170151601007	Abinaya R
9	170151601008	Aditya Subramanian V
10	170151601009	Afrose Farzana V A
11	170151601010	Afshana Thabasum A R
12	170151601011	Aisshvarya P
14	170151601013	Angelin Priscilla S
15	170151601014	Antony Jenish A
16	170151601015	Aravind Raj R
17	170151601016	Arifa Begum Y
18	170151601017	Arjun R
19	170151601018	Arshad Wahab

20	170151601019	Ashwin G Khedkar
21	170151601020	Asma Baig
22	170151601021	Barathan B
23	170151601022	Bouvanesh J
24	170151601023	Charlz Nithin J
25	170151601024	Charumathi D
26	170151601025	Dhanusha D
27	170151601026	Dinagar R
28	170151601027	Dinesh Kumar T
29	170151601028	Divya R
30	170151601030	Fariya Ahmed M
31	170151601031	Gayathri S
32	170151601032	Hari Priyaa M
33	170151601033	Harini A T
34	170151601034	Harini R M
35	170151601035	Hemashree K
36	170151601036	Hurrathul Fazila R I
37	170151601037	Ishwarya M
38	170151601038	Jamira Begam F
39	170151601039	Janani J
40	170151601040	Janani Prabha G
41	170151601042	Jaulikar Mohamed Saalis
42	170151601043	Javvadi Girish Naidu
43	170151601044	Jeevitha A
44	170151601046	Kamala Varshini S
45	170151601048	Karthika Devi U
46	170151601049	Kathija N
47	170151601050	Keerthivasan S
48	170151601051	Kiran Govind R
49	170151601052	Lakshmi Shruthi K M
50	170151601053	Lubna Talath S H
51	170151601054	Karthik Meyyappan M
52	170151601055	Manaal Sheerin Khan
53	170151601056	Namita Nanda
54	170151601057	Zainab Rahmath M
55	170151601058	Sabeena B
56	170151601059	Mathivadhani C
57	170151601060	Mohamed Jamalkhan S
58	170151601061	Mohamed Juvad N

59	170151601062	Mohamed Niyaz H
60	170151601063	Mohammed Imaad Khan T
61	170151601064	Mohammed Muzzammil A
62	170151601065	Mohammed Nashith A N
63	170151601066	Mohamutha Farshana T
64	170151601068	Mubeena U
65	170151601069	Muneer S
66	170151601070	Muthu Parvathi B
67	170151601071	Muzaiyen
68	170151601072	Mydeen Fathima S
69	170151601074	Nashiha Begum K
70	170151601075	Navyatejashree S Reddy Mullangi
71	170151601076	Neeraja P
72	170151601077	Nimitha R
73	170151601078	Nisha A S
74	170151601079	Ozair Jainul Hussain
75	170151601080	Parveen Shanofer S B
76	170151601081	Pavithra G
77	170151601082	Pooja C
78	170151601083	Prasad S P
79	170151601084	Preesha Christina Anand
80	170151601085	Princy J
81	170151601086	Rabiathul Shameera S M
82	170151601087	Radhika K
83	170151601089	Mohamed Shuaib S S
84	170151601090	Sadassivam P
85	170151601091	Sadiya Aafreen G
86	170151601092	Sadiya S
87	170151601093	Saiprem P
88	170151601094	Salma Mohamed Firdouse
89	170151601095	Sana Shaik R
90	170151601097	Shameera Begum B
91	170151601098	Shanib C
92	170151601100	Shobana V S
93	170151601101	Srivasunthara U
94	170151601102	Supraja TAP
95	170151601103	Sushmitha M
96	170151601104	Swarna Malya R
97	170151601105	Syed Faisal J

98	170151601106	Syed Masood Ahmed G
99	170151601107	Vengadesan D
100	170151601108	Vishal Sankrithi B J
101	170151601109	Viswaa Darshan B
102	170151601110	Yaasmin Barkath Bi K
103	170151601111	Zubeida Anjum M A
104	170151601112	Asnija Fathima S
105	170151601113	Mohamed Ahmed
106	170151601114	Syed Atif Ali
107	170151601115	Aakila Banu J
108	170151601116	Jeevidha V
109	170151601117	Karishma G R
110	170151601118	Mohamed Akif S
111	170151601119	Mumtaz Jabeen A
112	170151601120	Nivedhitha Sridhar
113	170151601121	Rahul Krishna G
114	170151601122	Vishva K
115	170151601123	Zuhaib Imaz B
116	170151601126	Mohd Yusuf K
117	170151601128	Kaaviya B
118	170151601133	Yalavadi Asma
119	170151601134	Mohd Azeem M
120	170151601135	Saabira Banu
121	170151601137	Priyadarshini A
122	170151601139	V Harinishree
123	170151601140	Mohd Abdul Ahad R

M.Tech (Biotechnology (II SEM))

S. No	RRN	Name
1	171442601001	ANTHONY ROXON M
2	171442601002	DONY JOSE
3	171442601003	FATHIMA SAMEENA M
4	171442601004	HARSHA HARIDAS
5	171442601005	ISHWARYA R
6	171442601006	MOHAMMED ABRAR BASHA
7	171442601007	SHOWKAT AHMAD LONE

M.Sc Biotechnology (II SEM)

S. No	RRN	Name
1	170542601001	Aravindh A
2	170542601002	Balaji Prasanna Kumar G
3	170542601004	Mahalakshmi
4	170542601005	Md. Adnan
5	170542601006	Rumelee Das
6	170542601008	Santosh Kumar M
7	170542601009	Syed Shafreen Azhari
8	170542601010	Thajul Vaslin M
9	150542601004	Buhaisath K T

M.Sc Microbiology (II SEM)

S. No	RRN	Name
1	170532601001	Abdullah
2	170532601002	Nehavarshini V
3	170532601003	Nirupama TV
4	170532601004	Pavithra S
5	170532601005	Sai Lakshmi

M.Sc Biochemistry and Molecular Biology (II SEM)

S. No	RRN	Name
1	170562601001	Arivazhagan R
2	170562601002	Pavithra P
3	170562601003	Santhosini



Outcome of the field visit

1. Students interacted with all the scientists and technicians.
2. Students learned the working principles and operating details of various bioanalytical techniques such as HPLC, electrophoresis, Chromatography, various types of centrifuges.
3. Students learned the various disease models of animals and their usage and how to handle small animals.
4. Students understood the importance of toxicological studies of various drugs and the methods of evaluation of toxicity studies.

Co-ordinator

(VIMAL KUMAR)

(FARIDHA BEGUM)

Dean, SLS

DEAN

School of Life Sciences
B.S. Abdur Rahman

Crescent
Institute of Science & Technology
Vandalur, Chennai-600 040

**INDUSTRIAL VISIT PROJECT REPORT ON
“TOOLS FOR BIOTECHNOLOGISTS”**

**Visited to Eppendorf india Limited, Sidco Industrial estate,
Ambattur, Chennai, Tamil Nadu**

BTB3104 Bioprocess Engineering

Course Content: Module 6: Reactor Engineering

Faculty coordinator: Dr. Karthikeyan R (Associate Professor)

Dr. Vimal Kumar (Assistant Professor)

Class: B.Tech (6th SEM students)

Number of Students: 73



EPPENDORF India Ltd.

In touch with life

Preamble: An industrial visit to “Eppendorf India Limited, Sidco Industrial estate, Ambattur, Chennai-58, Tamil Nadu was organised by the school of Life Sciences on 22.01.2019 (Tuesday). Seventy three students of B.Tech 6th SEM students with two coordinators from school of Life sciences namely Dr. Karthikeyan Ramalingam and Dr. Vimal Kumar visited the company. In this visit students learned bioanalytical techniques such as centrifuge section, Pipettes section, Fermenter section, Cell culture section, PCR/RTPCR section, Microscopic section

Salient features: Eppendorf india Limited is a leading life science company that develops and sells instruments, consumables, and services for liquid-, sample-, and cell handling in laboratories worldwide. Its product range includes pipettes and automated pipetting systems, dispensers, centrifuges, mixers, spectrometers, and DNA amplification equipment as well as ultra-low temperature freezers, fermentors, bioreactors, CO2 incubators, shakers, and cell manipulation systems. Consumables such as pipette tips, test tubes, microtiter plates, and single-use bioreactor vessels complement the range of highest-quality premium products.





DETAILS OF THE STUDENTS PARTICIPATED

B. Tech Biotechnology (IV SEM A Section)

1	160151601002	ABERNA S
2	160151601003	AHAMED ATHEEF N A
3	160151601004	ANITHA S
4	160151601005	ANUPAMA V
5	160151601006	ARSHIYA A
6	160151601007	ARUN KUMAR T C
7	160151601008	ASHWIN K
8	160151601009	ASLAM AHMED.M.S.
9	160151601010	AYESHA SIDDIQUA K
10	160151601012	AYISHA MUNAWWARAH
11	160151601013	BARAKATHUNISA H
12	160151601014	DEEPAK A
13	160151601015	DEEPIKA A H
14	160151601016	DEVADARSINI T
15	160151601017	DINESH B
16	160151601018	DINESH P R
17	160151601019	FAIZA FATHIMA A S
18	160151601020	FARHEEN N
19	160151601021	FATHIMA N I
20	160151601022	GAYATHRI M
21	160151601023	GOKUL NAINAR S

22	160151601025	HAJEERA BANU A
23	160151601026	HASEENA BEGUM P
24	160151601027	HAWAMA M
25	160151601028	HIKHMATHUNNISA S N
26	160151601029	ILAKKIYA R
27	160151601030	ILAYABHARATHI V
28	160151601031	JAINUL AFRIN ASHIKA K
29	160151601032	JANNET REFONA J K
30	160151601033	JAYASHREE B
31	160151601034	JENISHA BEGAM.H
32	160151601035	KASHIFA FATHIMA J
33	160151601036	KIRANBABU R
34	160151601037	KIRUBHA SANKAR S
35	160151601038	KRITHIKA.V.
36	160151601039	MANCY A
37	160151601040	MARWAN S M

B. Tech Biotechnology (IV SEM B Section)

1	1600151601041	MOHAMED DHARWISH M
2	1600151601042	MOHAMED SYED SHAIK ISMAIL G
3	1600151601043	MOHAMMED SHAJIUDDIN
4	1600151601044	MOHSEEN FATHIMA S
5	1600151601045	NAIFA JAMEEL K
6	1600151601046	NARENDRAN R
7	1600151601047	NAZIYA SAYEED H
8	1600151601048	NIKITHA SHERIN NISAR

9	1600151601049	NISHA K
10	1600151601050	NIVEDITA V
11	1600151601051	POOJA P A
12	1600151601052	PRADEEP PARTHASARATHY M
13	1600151601053	RAMEEZA BANU S
14	1600151601054	RISHIVANTH S
15	1600151601056	RUKAIYA HASANI KHASAMWALA
16	1600151601057	SAFIYA HUSSAIN
17	1600151601058	SAMRIN ABDUL SATHAR
18	1600151601059	SEDHA MAMTHA V
19	1600151601060	SELVARAJ MUKESH
20	1600151601061	SEVENTHI S
21	1600151601063	SHANAZ SALMA J
22	1600151601064	SHRIRAM S
23	1600151601065	SONIYA A
24	1600151601067	SRIRAM B
25	1600151601068	SYED ASFAR LATHIF S
26	1600151601069	SYED FAHAD S
27	1600151601070	THARANI P
28	1600151601071	UMME KULSUM. R.
29	1600151601072	VAANI A C
30	1600151601073	VINODHINI C
31	1600151601075	Akshaya T
32	1600151601076	ANGEL SHARON P.
33	1600151601078	ROSHINI P
34	1600151601080	RAMYAKRISHNAN R
35	1600151601081	MAHALAKSHMI M
36	1600151601085	SHAHARIYAR K.M

Outcome of the field visit

1. Eppendorf India limited is one the largest manufacturers of all the bio analytical instruments for the laboratory purposes. Hence, students learned about the maintenance and internal organization of all the instruments.
2. Students learned the working principles and operating details of various bioanalytical techniques such, Pipettes, Fermenters, Cell culture instruments PCR/RTPCR work station, Microscopic section, various types of centrifuges.
3. Students learned about handling of pipettes and calibration of pipettes.

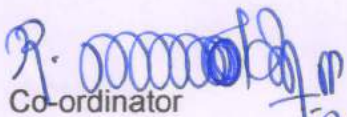
Co-ordinator
30/01/2019

Dean, SLS
DEAN
School of Life Sciences
B.S. Abdur Rahman
Crescent
Institute of Science & Technology
Jandalur, Chennai-600 048.



INDUSTRIAL VISIT PROJECT REPORT ON
“KNOWING THE FOOD MICROBES AND TOXINS”

**Visited to Hi Rise Food Tech Lab, Golden Jubilee Biotech Park
for Women society, Siruseri, Chennai, Tamil Nadu**

LSCX 113 FOOD BIOTECHNOLOGY

Course Content: Module 5 & 6: Food storage & Food Quality and Control

Faculty coordinator: Dr. P. Ashok Kumar (Assoc Prof)

Class: B.Sc. Biotechnology (IV SEM)

Number of students: 21



Preamble: An industrial visit to “Hi-Rise Food Tech Lab” located in “Golden Jubilee Biotech Park for Women society” in Siruseri, Chennai, Tamil Nadu was organised by the school of Life Sciences on 06.02.19 (Wednesday). Twenty one students of B.Sc Biotechnology (IV SEM) with class advisor Dr. Ashok Kumar P (Assoc. Prof) visited the lab. In this visit students learned to diagnose the food contaminant and microbial culture techniques. Dr. Ramya (Founder and Chief Scientist) demonstrated all the activities of the lab.

Food Toxins:

- Some natural toxins can be formed in food as defence mechanisms of plants, through their infestation with toxin-producing mould, or through ingestion by animals of toxin-producing microorganisms.
- Natural toxins can cause a variety of adverse health effects and pose a serious health threat to both humans and livestock. Some of these toxins are extremely potent.
- Adverse health effects can be acute poisoning ranging from allergic reactions to severe stomach ache and diarrhoea, and even death.
- Long-term health consequences include effects on the immune, reproductive or nervous systems, and also cancer.

Salient features: HiRise lab received food samples from hotels, hostels; food company's to check the quality of the food. They equipped with Incubator, biosafety cabinets, colony counter and UV –Visible spectrophotometer to analyse the food quality. Students interacted very well with Dr. Ramya and got the awareness of food testing and its importance's.





DETAILS OF THE STUDENTS PARTICIPATED

B.Sc. Biotechnology (IV SEMESTER)

S. No	RRN	STUDENTS NAME
1	171391601001	AMREEN BANU K
2	171391601002	ANURADHA S
3	171391601005	GOKULANANDAN K
4	171391601007	JANANI D
5	171391601008	JASELA BANU N
6	171391601009	JEEVITHA P
7	171391601012	KAVIYA S
8	171391601013	KAVYA C
9	171391601014	LEENA STEEFINA G
10	171391601016	MANJULA V
11	171391601017	MOHAMED YASAR A H
12	171391601018	NAFIDHA RAHMATH B
13	171391601019	P ILLAKYA
14	171391601020	PRADEEPA A
15	171391601021	SAHIRA NASEEM S B
16	171391601023	SHAHAZ AFREEN M S
17	171391601024	SOPHIA J
18	171391601025	SRINITHIYA S
19	171391601026	WASIFHA IDRIS HUSSANIY SYED
20	171391601027	JAWAHAR A
21	171391601028	JAGATHRAKSHAKAN



B.S. Abdur Rahman

Crescent

Institute of Science & Technology
Deemed to be University u/s 3 of the UGC Act, 1956

Outcome of the field visit

1. Students understood the common microbes and toxins that affect food.
2. Students learned how to take food sample for testing and what are all the conditions that a food needs to be checked?
3. Students learned the basic equipment's that are necessary for the food testing lab.
4. Students interacted with the Dr. Ramya, Director of HiRise lab and exposed to entrepreneurial skills.

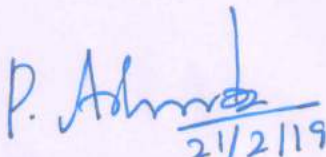
21/2/19
Co-ordinator

Dr. P. Ashok Kumar, Ph.D
Associate Professor
School of Life Sciences
B.S. Abdur Rahman Crescent Institute
of Science and Technology
Vandalur, Chennai - 600 048.

20/2/19
Dean, SLS

DEAN
School of Life Sciences
B.S. Abdur Rahman
Crescent
Institute of Science & Technology
Vandalur, Chennai-600 048



B.S. Abdur Rahman

Crescent

Institute of Science & Technology
Deemed to be University u/s 3 of the UGC Act, 1956
GST Road, Vandalur, Chennai 600 048



B.S. Abdur Rahman

Crescent

Institute of Science & Technology
Deemed to be University u/s 3 of the UGC Act, 1956
GST Road, Vandalur, Chennai 600 048

School of Arabic and Islamic Studies

Field Visit Report

Date: 07.02.2019

No. of Students: 40

No. of Faculty: 2

DEAN
School of Arabic & Islamic Studies
B.S. Abdur Rahman
Crescent
Institute of Science & Technology
Vandalur, Chennai-600 048.



Report on Field (Institutional) Visit

I. Preamble:

Apart from the routine Classroom teachings, field trips in the form of visiting other educational and vocational institutes will provide practical insights to various teaching pedagogies and practices to the students. The students also can learn the learning process, resources, standards and other important aspects of that particular institute. These visits will also help the students to have a better view of the learning and teaching environment and also a chance to meet and interact with the people associated with these institutions.

II. About the visit:

On 7th February 2019, 40 students from B.A. Islamic Studies (Final Year) along with two faculty members visited Yousuffiya Arabic College located in Dindugal.

The objectives of this field trip were to expose students:-

- i. To practically grasp the layout and structure of a traditional Arabic College
- ii. To practically observe the teaching methodologies followed in colleges like that.
- iii. To acquire knowledge regarding the curriculum, syllabus, study materials and reference books used.
- iv. To visit the college library and list out the rare and classical Arabic books available there.

The list of students who participated in the institutional visit is attached below:

S.No.	RRN	Name
1	160111601001	ABDUL HALEEM S
2	160111601002	ABDUL RASHIK A
3	160111601003	ASADULLAH A
4	160111601004	ASHIF RAHMAN M S
5	160111601005	ASHRAF ALI T
6	160111601006	EJAS AHAMED J
7	160111601007	IBRAHIM J
8	160111601008	IDAYATHULLA S
9	160111601009	IMTHIYAS S
10	160111601010	KATAKA MOHAMMED ASFAR ALI
11	160111601011	MOHAMED AMJEETH IBRAHIM M
12	160111601012	MOHAMED ASIF B
13	160111601013	MOHAMED FAZIL S



B.S. Abdur Rahman
Crescent

Institute of Science & Technology
Deemed to be University, U-3 of the UGC Act, 1956
GST Road, Vandalur, Chennai 600 048

14	160111601014	MOHAMED FROOZ A
15	160111601015	MOHAMED HASHEEM S A
16	160111601016	MOHAMED IRFAN J
17	160111601017	MOHAMED JALALUDEEN S
18	160111601018	MOHAMED JAVID G Z
19	160111601019	MOHAMED RIFAI H
20	160111601020	MOHAMED RIYAS M
21	160111601022	MOHAMED THARIQ A S
22	160111601024	MOHAMMED ALI KHAN H
23	160111601025	MOHAMMED DAWOOD ANSARI V A
24	160111601026	MOHAMMED FAZIL M
25	160111601027	MOHAMMED FAZIL N
26	160111601028	MOHAMMED MALIQ R K
27	160111601029	MOHAMMED MASIULLAH
28	160111601030	MOHAMMED VAJAKATH NOUFAL S S
29	160111601031	MUHAMMAD IRFANUL HAQ A
30	160111601032	NAFEES AHAMED SIDDHICK M
31	160111601033	NAFEES ALI M
32	160111601034	RIYAS ABDUL HAMEED A
33	160111601035	S ABUBAKKAR SIDDIK
34	160111601036	SADIQ BASHA J
35	160111601037	SHAHITH AHAMED N
36	160111601038	SHEIK ABDUL KATHAR SUHAIL P M
37	160111601039	THOUFEEK ASLAM M
38	160111601040	THOWFIK AHAMED J
39	160111601041	ABDUL MALIK M
40	160111601044	YASAR ARAFATH B

Dr. A. M. Muhiyadeen Lebbai and Mr. M. Ahamedullah accompanied the students during this visit.

Details of the visit:

Students and staff members reached Dindugal by train and then reached Yousufiyya Arabic College by a bus. After completing the breakfast, they were taken to roam around the campus. Our students visited all the hostel buildings, Masjid, kitchen, canteen and all the amenities provided for the students.

Then, the students visited the class rooms and attended classes taken on important subjects like Arabic Grammar, Quranic Exegesis, Islamic Jurisprudence, Arabic Literature. During the classes, they

raised questions and cleared their doubts with the respective teachers. They also talked in Arabic with them as that is our medium of teaching learning process. Couple of our students also delivered elocution in Arabic as well.

Then, the students completed their Dhuhar prayer and had their lunch in the Yousufiyya Arabic College's mess.

After that, the syllabus and curriculum followed there were explained by the senior professors working there. Students listened to that carefully and asked questions about some of the courses included and the courses which were not incorporated in the syllabus.

Finally, they all visited the college library which had huge volumes of Arabic books starting from Tafseer, Hadeeth, Fiqh, Usool Al Fiqh etc. They spent their valuable time there by going through some of the important books. They also took notes from those books.

Our students had interacted with the students of Yousufiyya Arabic College and exchanged their views, opinions and experiences. Faculty Member Dr. Muhiyadeen Lebbai also delivered a special guest lecture to all the students on the importance of knowledge gaining and its implications.

Outcomes of the visit:

After the field visit, the students were able to:

- i. Understand the structure and infrastructure of traditional Arabic colleges.
- ii. Figure out the teaching methodologies, pedagogies and practices followed.
- iii. Comprehend the syllabus, curriculum, text books and reference materials followed in traditional Arabic colleges.
- iv. Explain the structure and components of the libraries in traditional Arabic colleges.

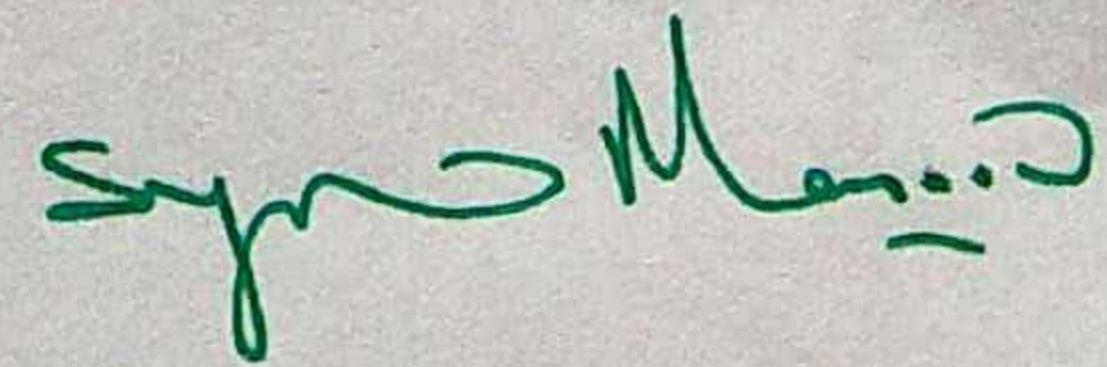

DEAN
School of Arabic & Islamic Studies
B.S. Abdur Rahman
Crescent
Institute of Science & Technology
Vandalur, Chennai-600 048,



B.S. Abdur Rahman
Crescent

Institute of Science & Technology
Deemed to be University Act 1987 Sec. 3
GST Road, Vandalur, Chennai-600 048

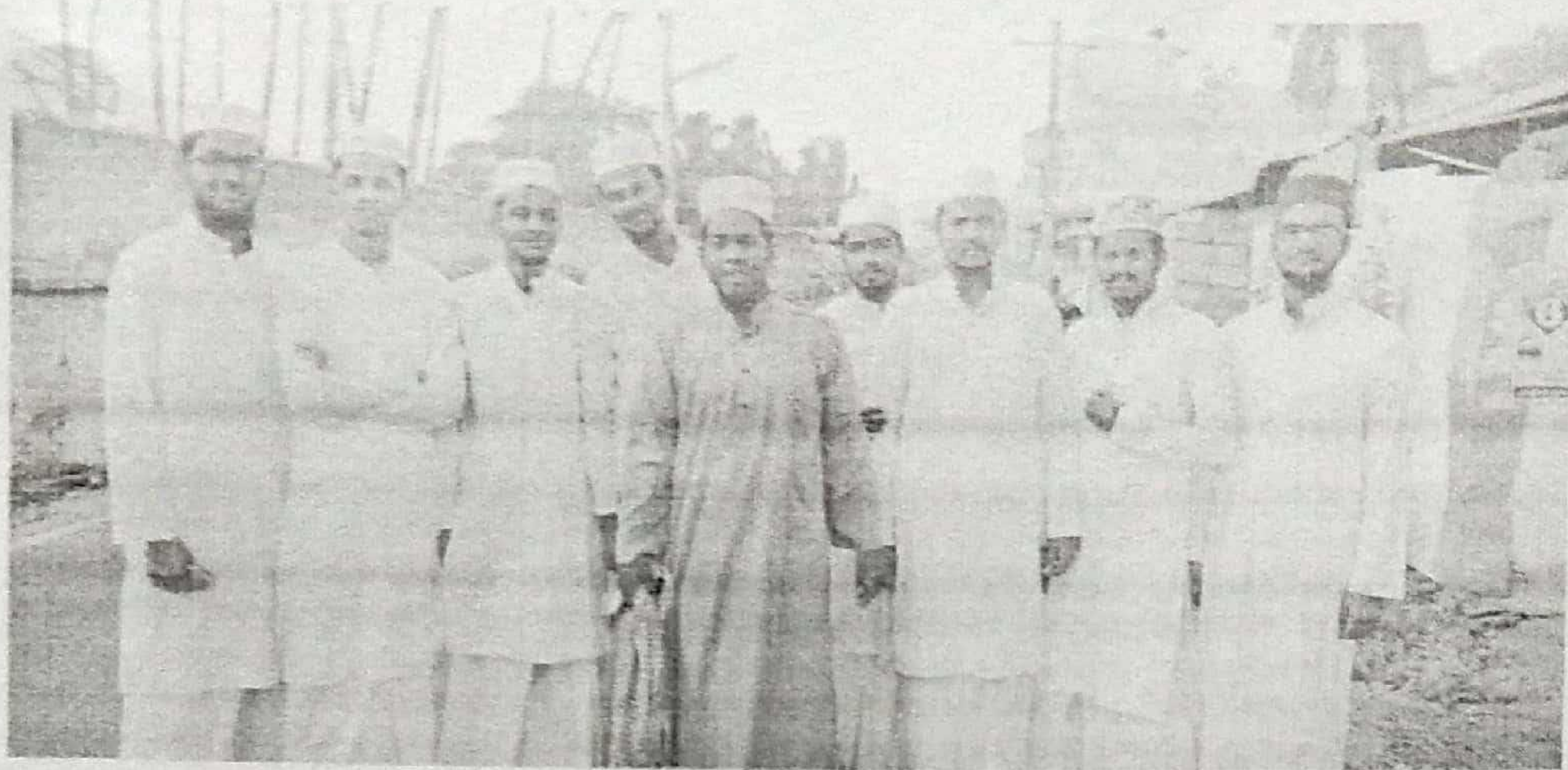

Syamsuddin

DEAN
School of Arabic & Islamic Studies
B.S. Abdur Rahman
Crescent
Institute of Science & Technology
Vandalur, Chennai-600 048



Scanned with
CamScanner



B.S. Abdur Rahman

Crescent

Institute of Science & Technology

Deemed to be University u/s 3 of the UGC Act, 1956

INDUSTRIAL VISIT REPORT

To study on a working Principle of Sewage Treatment Plant- Perungudi, Chennai

Date of Visit: 26-04-2018

No. of Students: 24

Staff Co-ordinator : Mr. Y. Ibrahim



J. Flori *26/04/19*

DEAN (ACADEMIC AFFAIRS)

B.S. Abdur Rahman Crescent
Institute of Science & Technology

Vandalur, Chennai - 600 048.

The details of students participated in the project are as follows:

Sl. No.	RRN	Name
1.	150011601024	AVILALA ANANTHA KUMAR
2.	150011601081	NIYAZ KHAN
3.	150011601145	MUTHUKRISHNAN. R
4.	160011601008	AHAMED JALAL G
5.	160011601045	MOHAMED RASHEED P
6.	160011601046	MOHAMED RASHITHTHURAI M
7.	160011601047	MOHAMED RIFFON M
8.	160011601048	MOHAMED SABITH A
9.	160011601049	MOHAMMED AQUEED USAYEED A.S
10.	160011601050	MOHAMMED FAROOQ J
11.	160011601051	MOHAMMED FAZULUR RAHMAN K
12.	160011601052	MOHAMMED MUJAMMIL.H
13.	160011601053	MOHAMMED SHAFIR A
14.	160011601054	MOHAMMED SHAHID AFRAZ
15.	160011601055	MOHAMMEDJAINOOLBHASARATH K
16.	160011601056	MUADH M F
17.	160011601057	MUHAMMAD ASHRAF M
18.	160011601058	NERESH KUMAR S
19.	160011601059	NOUSHAD AHAMED C M
20.	160011601060	OMAR A
21.	160011601061	RAM KUMAR R
22.	160011601063	SAANTHANU B
23.	160011601064	SANTHOSH BALAN P
24.	160011601066	SHAHIN AHAMED B

DEAN (ACADEMIC AFFAIRS)
B.S. Abdur Rahman Crescent
Institute of Science & Technology
Vandalur, Chennai - 600 048.

Abstract

This report presents the experience we had and the processes that are going in the plant. A visit to Perungudi sewage treatment was carried as a project-based learning for the subject, 'Water and Waste Water Engineering'. The plant is located in perungudi. This sewage treatment plant is under the Chennai metropolitan municipal corporation. This treatment plant is responsible for the sewage produced in southern areas of Chennai like Adyar, Velachery, Pallavaram, etc., The capacity of the plant is 135 MLD. We were explained the treatment process of the sewage at different phases and the live demonstrations of how the systems work.

Introduction

The Perungudi Sewage Treatment Plant is located in Perungudi, Chennai. The plant treats the sewage from Zone 5 of Chennai Corporation, which covers a large part of southern Chennai like Adyar, Velachery, Perungudi, Alandur, Pallavaram, etc., The sewage is pumped to the STP by 49 individual pumping stations. The plant has three phases (I, II, III) with capacities 54, 60 and 16 MLD respectively.

The plant is based on conventional activated sludge process with anaerobic sludge digestion and biogas utilisation by means of a power generation plant based on gas engine of capacity 1317 KVA.

Process Flow Diagram

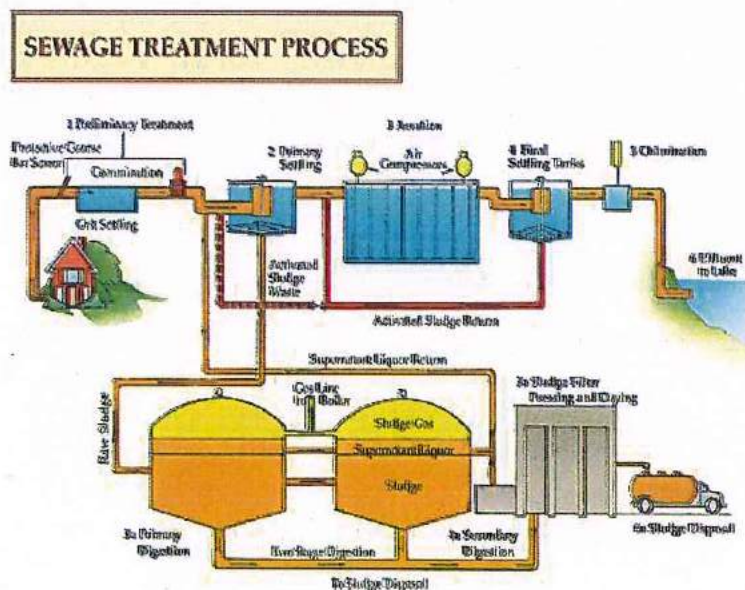

Different units of Sewage treatment

Inlet Chamber

The first unit is Inlet Chamber, in which the discharge from Common rising main through Raw Sewage Pumps is received. The inlet chamber is mainly used to control the velocity of raw

A. K. Ravi
02/04/19

influent and also for its smooth distribution of flow to the fine screen channel. In Perungudi sewage water treatment plant it collects raw sewage from south Chennai of 54 MLD of sewage.

Screen Chamber

Screening is the first unit operation used at wastewater treatment plants (WWTPs). Screening removes objects such as rags, paper, plastics, and metals to prevent damage and clogging of downstream equipment, piping, and appurtenances. Some modern wastewater treatment plants use both coarse screens and fine screens. The screen chamber in Perungudi is of dimension 10.0m x 0.89m



Grit Chamber

Grit chambers are basin to remove the inorganic particles to prevent damage to the pumps, and to prevent their accumulation in sludge digesters. The dimension is 11.6 x 0.8m LD.

Primary Clarifier

The purpose of a Primary clarifier is to remove solids, produce a cleaner effluent and concentrate solids. Concentration of solids removed from the wastewater reduces the volume of sludge for dewatering and or disposal. The smaller the volume of sludge removed results in lower capital and operating costs for dewatering equipment and/or sludge disposal. Sometimes existing dewatering equipment may not have enough capacity if the sludge is not concentrated.



B. S. Abdur Rahman
DEAN (ACADEMIC AFFAIRS)
B.S. Abdur Rahman Crescent
Institute of Science & Technology
Vandalur, Chennai - 600 048.

Sludge Digester

A sludge digestion tank is a room or compartment into which settled sewage solid wastes are placed, away and apart from the sewage or settling tanks, under proper anaerobic conditions, the solids will undergo decomposition, the results of which are partial liquefaction gasification of volatile matter, and a partial breaking of the bond which holds the solids in aqueous solution or colloidal suspension. At the final stage which is called the gasification stage, the organic acid produced in the previous stage is used by certain microbes as substrate and methane and carbon dioxide gases are produced as a result. This stage is slower it leads to production of methane.

Gas Holder

A **gas holder**, is a large container in which **natural gas** or **town gas** produced from the **sludge digester** is stored near **atmospheric pressure** at **ambient temperatures**. The volume of the container follows the quantity of stored gas, with pressure coming from the weight of a movable cap.

In drainage waste water treatment plant the gas holder is used to store the methane gas which is acquired from the sludge treatment as we observed in our INDUSTRIAL VISIT

Aeration tank

The biological treatment of the wastewater takes place in the aeration tank. Before the wastewater gets to this tank, it is mixed with activated sludge. This contains countless microorganisms, such as bacteria, that can break down the colloidal, organic contaminants dissolved in the wastewater. The air pumped in pipes and is diffused through a diffuser from the bottom of the tank.

Sewage liquor is run into deep tanks with **diffuser** grid aeration systems that are attached to the floor. These are like the diffused **air stone** used in **tropical fish** tanks but on a much larger scale. Air is pumped through the blocks and the curtain of bubbles formed both oxygenates the liquor and also provides the necessary mixing action. Where capacity is limited or the sewage is unusually strong or difficult to treat, oxygen may be used instead of air. Typically, the air is generated by some type of blower or compressor.

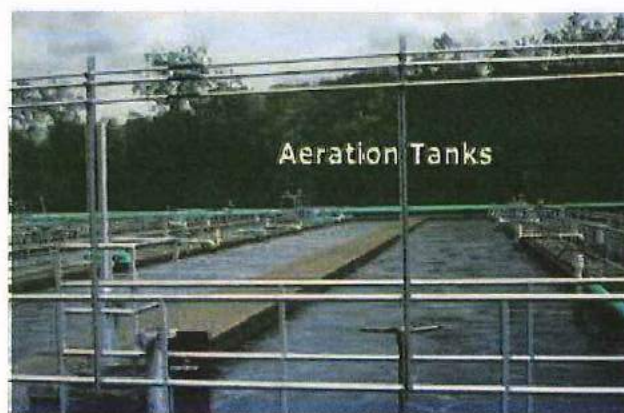

A. Torri
DEAN (ACADEMIC AFFAIRS)
B.S. Abdur Rahman Crescent
Institute of Science & Technology
Vandalur, Chennai - 600 048.

Secondary clarifier

A circular basin in which effluent from the activated sludge process is held for a period of time during which the heavier biomass (microorganisms) settles to the bottom as “activated sludge.” This sludge, teeming with hungry microorganisms, can be returned to the first aeration basin to begin the activated sludge treatment process all over again.

Centrifuge for sludge handling

Centrifugation has been demonstrated to be capable of thickening a variety of wastewater sludges. Centrifuges are a compact, simple, flexible, self-contained unit. They have the disadvantages of high capitals, maintenance and power costs and often a poor, solids-capture efficiency if chemicals are not used for bio sludges.

Centrifugal thickening is acceleration of sedimentation through the use of centrifugal force. Centrifuges are commonly used for thickening the Waste Activated Sludge. Primary sludge is normally not fed to centrifuge as it may contain abrasive material. In addition of being effective in thickening, they have additional advantage of less space requirement, less odour potential & housekeeping requirement. The energy of centrifugal for sludge handling is 10HP.

Final effluent pump house

Thus, the treated sewage water, which is called Effluent is pumped to the final effluent pumping station. There the pumps will pump the treated sewage water into the water bodies.

Bio-gas Engine

The gas thus produced from the sludge decomposition is pumped to the gas-engine. Where, it will be combusted to produce energy. The gas engine at Perungudi STP is capable of producing around 10 MW /day.



DEAN (ACADEMIC AFFAIRS)
B.S. Abdur Rahman Crescent
Institute of Science & Technology
Vandalur, Chennai - 600 048.

QUALITY OF EFFLUENT STANDARD

- i. As per TNPCB - BOD=20mg/litre S. S=30mg/litre
- ii. As achieved in the plant - BOD less than 20mg/litre
- S.S less than 30mg/litre
-Fecal Coliform less than 10,000MPN/100ml

CONCLUSION

The Perungudi sewage treatment plant operates in the Zone-V of Chennai corporation, which is the second largest of the five macro systems and is to the South of the City which is bifurcated by the Adyar River. Areas covered are Ice House, Mylapore, Adyar, Guindy, Velacherry, Gandhi Nagar, Indra Nagar etc. Each day average 54 ML is treated and a Peak flow of 135 MLD. Although the Perungudi sewage treatment is allegedly known for polluting the Perungudi area, it is still doing a fair job in the treatment of the Chennai's Sewage. The government has planned to add another few units to the STP to increase its Standards

y. shorahim

Name & Signature of Staff Co-ordinator

Vasanthi P

Dean, School of Infrastructure

DEAN
School of Infrastructure
B.S. Abdur Rahman
Crescent
Institute of Science & Technology
Vandalur, Chennai-600 048.

J. Hari
DEAN (ACADEMIC AFFAIRS)
B.S. Abdur Rahman Crescent
Institute of Science & Technology
Vandalur, Chennai - 600 048.



Field Project report

SUNSHINE SCHOOL-

20-Jul-18

Crescent School of Architecture
CSA

Field Project report

SUNSHINE SCHOOL

Sunshine Montessori school , architect designed a unique settings for education have been created to occur with a mix of interior classrooms and teaching areas, central atrium space and play spaces for children.

Preamble :

Sunshine is an architect designed school which well planned , located in the heart of the city , easily accessible .Creative and optimistic learning environment.. The new building is constructed in 2010, Velachery creates the unique and holistic learning environment for children.

Student List :

S.NO	RRN.NO.	NAME OF THE Student
1	170101601001	ABDUR RAHMAN M
2	170101601002	ADARSH TS
3	170101601003	AISHWARYA A
4	170101601004	AISHWARYA BANERJEE
5	170101601005	AKALYA P
6	170101601006	APARNA GAYATHRI

7	170101601007	BIBINA ACQULIN J.
8	170101601008	DEEPTHI B
9	170101601009	FAHEEMA HAJA
10	170101601010	FATHIMA ZAHRA MUSHTAQ KHAN
11	170101601012	HEMALATHA G
12	170101601013	KARTHIKEYAN. B
13	170101601014	KEERTHANA PRIYA R
14	170101601015	MAHMOOD MUNSIF M.A.C.
15	170101601016	MEENUABIRAMI S.
16	170101601017	MOHAMED AJMAL J
17	170101601019	MOHAMED ASLAM MUSTHAF A S
18	170101601020	MOHAMED IBRAHIM. Z
19	170101601021	MOHAMMED ABDAL HUSSAIN SOWDAGAR
20	170101601022	MOHAMMED FARHAN S.
21	170101601023	MUHAMMED ZAKI IQBAL
22	170101601024	MUKESH. C
23	170101601025	NAMITHA RAMESH
24	170101601026	NISHITHA R.
25	170101601027	PRATHIBHASRI SRIDHARANE
26	170101601028	RAGHUNANDHAN S.
27	170101601029	RASHIKA.R
28	170101601030	RASIKA.B
29	170101601031	REBECCA M
30	170101601032	REVANTH. S
31	170101601033	RUBINA SHANAS F
32	170101601034	SAMEERAH .M
33	170101601035	SANIYA AHMED
34	170101601036	SELVA RAHUL.S
35	170101601037	SHRUTHI RAJESWARI J.
36	170101601038	SRI VAISHNAVI. H
37	170101601040	SURYA A
38	170101601041	SWATHI. U
39	170101601042	SWATTHE ROSILY. P.J
40	170101601043	VISHAL R.
41	170101601045	LEKSHANA C

SailentFeatures :

At Sunshine instilled in practical experience and also a new perception on the prjoect. Further site visit provided a valuable opportunity, of learning from different architectural perceptions to all second year students of architecture Buildings and grounds are welcoming, safe and secure.

Good environmental condition throughout including optimum levels of natural light and ventilation. Well designed external spaces offering a variety of different settings for leisure, learning and sport

Photos :





Outcome :

- The students analyze the project in all the aspects and try to find ways to find solutions and solve problems..
- Experience the importance of Practical knowledge
- Understand the concept of planning structures of commercial buildings

S. Amin
Project Co.ordinator Sign
(Mr. S. DWARI)

21/09/18
Prof. G. Jayalakshmi,
Dean/ Crescent School of Architecture.
DEAN
Crescent School of Architecture
B.S. Abdur Rahman
Crescent
Institute of Science & Technology
Vandalur, Chennai-600 042

CASE STUDY REPORT

APOLLO CRADLE

LOCATION : Karapakkam, OMR
Date : **05.01.2019**



PREAMBLE

As a part of their curriculum, the students of 2nd Year B.Arch (IV semester) were to do a case study of a Hospital to understand the spaces and functioning of it to help them design better.

A group of 41 students and 2 teachers visited the facility on **05.01.2019** and gathered relevant information to proceed with the design process .

S.N	R. No	Name
1	170101601001	ABDUR RAHMAN M
2	170101601002	ADARSH TS
3	170101601003	AISHWARYA A
4	170101601004	AISHWARYA BANERJEE
5	170101601005	AKALYA P
6	170101601006	APARNA GAYATHRI
7	170101601007	BIBINA ACQULIN J.
8	170101601008	DEEPTHI B
9	170101601009	FAHEEMA HAJA
10	170101601010	FATHIMA ZAHRA MUSHTAQ KHAN
11	170101601012	HEMALATHA G
12	170101601013	KARTHIKEYAN. B
13	170101601014	KEERTHANA PRIYA R
14	170101601015	MAHMOOD MUNSIF M.A.C.

S.N	R. No	Name
14	170101601015	MAHMOOD MUNSIF M.A.C.
15	170101601016	MEENUABIRAMI S.
16	170101601017	MOHAMED AJMAL J
17	170101601019	MOHAMED ASLAM MUSTHAFA S
18	170101601020	MOHAMED IBRAHIM. Z
19	170101601021	MOHAMMED ABDAL HUSSAIN SOWDAGAR
20	170101601022	MOHAMMED FARHAN S.
21	170101601023	MUHAMMED ZAKI IQBAL
22	170101601024	MUKESH. C
23	170101601025	NAMITHA RAMESH
24	170101601026	NISHITHA R.
25	170101601027	PRATHIBHASRI SRIDHARANE
26	170101601028	RAGHUNANDHAN S.

S.N	R. No	Name
27	170101601029	RASHIKA.R
28	170101601030	RASIKA.B
29	170101601031	REBECCA M
30	170101601032	REVANTH. S
31	170101601033	RUBINA SHANAS F
32	170101601034	SAMEERAH .M
33	170101601035	SANIYA AHMED
34	170101601036	SELVA RAHUL.S
35	170101601037	SHRUTHI RAJESWARI J.
36	170101601038	SRI VAISHNAVI. H
37	170101601040	SURYA A
38	170101601041	SWATHI. U
39	170101601042	SWATTHE ROSILY. P.J
40	170101601043	VISHAL R.
41	170101601045	LEKSHANA C

Scope of Services

Anesthesiology	உணர்வகற்றியல்
Gynaecology	பெண்ணோயியல்
Immunization	நோய்த்தடுப்பு
Neonatology	சிறுகுழந்தை சிகிச்சை
Obstetrics	மகப்பேறியல்
Pediatrics	குழந்தை மருத்துவம்
Neonatal NICU	சிறு குழந்தை தீவிர சிகிச்சைப்பிரிவு
HDU	பிரத்தியேக தீவிர சிகிச்சைப்பிரிவு
Infection Control	கிருமி தொற்று கட்டுப்பாடு
Lab Services	ஆய்வுகூட சேவைகள்
Blood storage centre	இரத்த சேமிப்பு மையம்
Dentistry	பல் மருத்துவம்
General Medicine	பொது மருத்துவம்
Radiology & Imaging	கதிரியக்கவியல்
ECG	ஈசிஜி
X-Ray	எக்ஸ்-ரே
Mammogram	மேமோகிராம்
Dexa scan	டெக்ஸ் ஸ்கேன்
Ultrasound	அல்ட்ராசவுண்ட்
IUI lab	கருவூட்டல் ஆய்வுகூடம்

APOLLO MEDICAL CENTRE

FIRST FLOOR

1

RECEPTION
CONSULTATION SUITE
APOLLO HEALTH CHECK
ECG / ULTRASOUND
VACCINATION
MAMMOGRAM / PFT
X-RAY/ DEXA SCAN
BLOOD COLLECTION
TREATMENT ROOM
FEEDING ROOM
PLAY AREA
CAFETERIA
PHYSICALLY HANDICAPPED
TOILET

SECOND FLOOR

2

DAY CARE
PHYSIOTHERAPY
DENTAL CLINIC
IUI LAB
ROOM NO: 202 TO 215
OP PHARMACY

THIRD FLOOR

3

ROOM NO: 301 TO 315
BLOOD STORAGE CENTRE

FOURTH FLOOR

4

WAITING AREA
NICU / HDU
FEEDING ROOM / NURSERY
OPERATION THEATRE
LABOUR WARD
DELIVERY ROOM
PRE & POST WARD

Floor Plan



B.S. Abdur Rahman

Crescent

Institute of Science & Technology

Deemed to be University u/s 3 of the UGC Act, 1956

An ISO 9001:2015 Certified Institution



ENTRANCE

RECEPTION

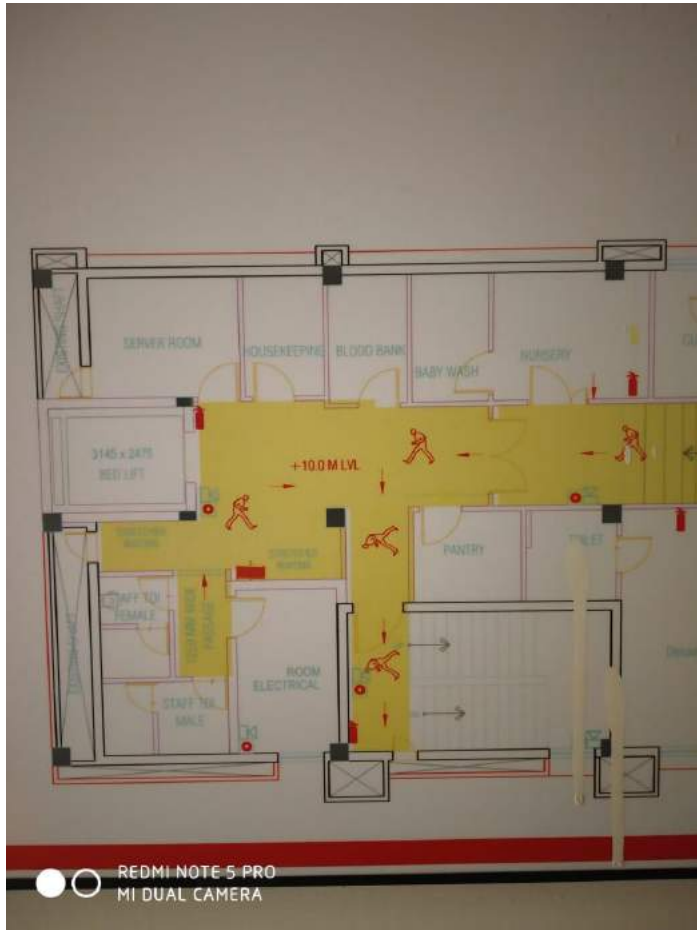

FIRE ESCAPE LAYOUTS



EMERGENCY ROOM



PAITENT'S SUITE ROOM

LABOUR ROOM





STUDENTS OF B.ARCH 2017-2022

OUTCOME

At the end of the case study the students had a clear picture of the functional organization of the various spaces in a hospital and the flow of functions within it. It helped them to design the Primary Health Care Centre – Part of their Studio Design.

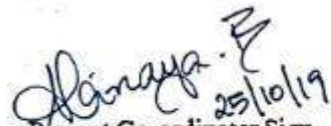
25/10/19
Project Co.ordinator Sign
(ABINAYA)

02/10/19
Ar. G. Jayalakshmi,
Professor & Dean
Crescent School of Architecture.

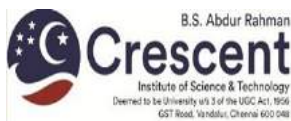

PRIYADARSHINI R <rriyadarshini@crescent.education>

APPROVAL for Industrial Visit on 20th Sept. 2018.

1 message

Surendar Marketing-Training [Sands] <mktg.trg@sandsindia.com>

Mon, Sep 10, 2018 at 9:17 AM

To: PRIYADARSHINI R <rriyadarshini@crescent.education>

Cc: "P Karthik Venkatesh [Sands]" <p.karthikvenkatesh@sandsindia.com>, Training Sands <sandstraining@sandsindia.com>, Site office Training <training@sandsindia.com>

Dear Ms.R.Priyadarshini,**Greetings From SANDS!!!**

With reference to trailing mail, We herewith **Approve** the **Industrial visit for total 50 students from 4th Year B.Tech. IT Dept., 3 students from 2nd Year M.tech.IT Dept. and 3 Staff Members from B.S.A. Crescent Institute of Science & technology, on 20th Sept 2018 (Thursday)**

Your Timing shall be from 10:00 am to 11:30am (1 1/2 Hrs only)The exposure shall be mainly in **IIOT & BIGDATA** for your Students.**Program Schedule:-**

- 1) Introduction to Industry & **SANDS** Products,
- 2) Introduction to Internet of Things & Big Data.
- 3) **SANDS** Product demo for 3-4 Nos for 5-7 minutes each
- 4) Discussion & Clarification about technology to students & Staffs
- 5) Tea Break
- 6) Departmental Visits

Please do call the undersigned for any further clarifications.**Kindly send your confirmation by mail.****Good day...****Thanks & Regards,****K.Surendar****Marketing Engineer****SANDS**®

SIGNALS & SYSTEMS (India) Pvt. Ltd.

15/D-19, SIPCOT I.T Park, Siruseri, Chennai - 603103.

Mob: +91- 9003262765, 9841718045 (WhatsApp)

Landline : 044 - 27470001, 27470003, 27470087, 27470088

Email: mktg.trg@sandsindia.comWebsite : www.sandsindia.comwww.sandscerebro.com

On Fri, Sep 7, 2018 at 12:28 PM, PRIYADARSHINI R <rriyadarshini@crescent.education> wrote:

Dear Sir/Madam,

As you may be aware, B.S.A Crescent Institute of Science and Technology, Chennai is one of the most reputed Institutions in Tamil Nadu and known for its excellent record in academics and co-curricular activities.

As a part of the curriculum, the students are required to undertake Industrial Visits to a few reputed industries. We would like to visit your organization, for one day such that the students can

have an industrial exposure to see various processes such as

We feel it will be fruitful for the students with the academic background having the glimpse of the industry in order to have a better appreciation of practical applications of theory.

In the above background, we would like to send a batch of about **total fifty (50) Students of IV** year B.Tech Information Technology and 3 students of II Yr. M.tech Information Technology. Department students accompanied by **three(3) staff members** to visit your esteemed industry preferably on **20.09.2018**.

I request you, to kindly accord the necessary permission for the above visit and make necessary arrangement for guiding the students.

I assure you that our students will observe the rules and regulations that are prescribed by your company for the visitors and will in no way disturb the functioning of the company during their visit.

I shall be grateful for a favorable response.

Thanking You,

Thanks and Regards,

R.Priyadarshini,

Assistant Prof. (Sr.Gr.),

Department of Information Technology,

B.S.Abdur Rahman Crescent Institute of Science and Technology,

Chennai-48.

[Crescent Profile](#) | [Google Scholar Profile](#) | [Scopus Profile](#) | [Research Gate Profile](#) | [Linked-In-Profile](#) |

2 attachments



SANDS IIoT products.pdf

365K



SANDS Learning Division.pdf

5321K

DEPARTMENT OF INFORMATION TECHNOLOGY

INDUSTRIAL VISIT – SANDS PVT. LTD.

The following students have attended Industrial visit on 20.09.2018 in SANDS PVT. LTD., Chennai on account of the course in M.Tech IT IT7101, Internet of Things.

S.No	RRN	Name
1	150081601002	AHAMED ABDUL KHADER A
2	150081601006	BOBSON CHURCHILL S
3	150081601007	BUSHRA SULTANA K
4	150081601008	BUVANESH J
5	150081601009	DINESH KUMAR.S
6	150081601010	DIVYA M
7	150081601013	HEM PRASANTH K C
8	150081601014	INUL MARLIYA H
9	150081601020	MOHAMMED IRFAN A
10	150081601024	MYDEEN ABDUL KADER
11	150081601025	NAVANEETH R JA
12	150081601028	RUHI ARSHIYA Z
13	150081601030	SALIL BAGGA
14	150081601031	SARTAJ.P
15	150081601032	SHAID HUSSAIN A
16	150081601035	SHAREEN S K
17	150081601036	SHARMILA BANU S
18	150081601039	SUMAIYA BEGUM I
19	150081601040	SUSAN KHANUM A
20	150081601043	VIDHYA S
21	181272601001	Serena Rajakumar
22	181272601002	K.Sowmiya
23	171272601001	AMIT S.
24	171272601002	KOWSHAL A.
25	171272601003	NIVETHA THIRUMAGAL N.



Industrial visit Report

Our college gave us the immense opportunity to visit a company named SANDS which is in Siruseri for industrial visit on Thursday (20/09/2018). We (25 students) were accompanied by M.Tech students and two of our very friendly and responsible staffs Dr.N.Prakash, Associate Prof., IT, Ms. R.Priyadarshini, Assistant Prof., IT for the IV. The company was very impressive with its huge and attractive infrastructure. As we entered there, they started the lecture with a video clip about machine learning which was very interesting to watch. Later we were taken to see their company owned products. They gave explanation to each of their products one by one. The products were,

- TPRS-1107 (three phase reference standard meter) is portable equipment. The main objective of this device is to calibrate the errors in three-phase and single-phase energy meters i.e. the meter under test (MUT). The TPRS supports both static and electro-mechanical types of meters. It can also be used to compute the voltage, current, energy, power factor etc of the meter under test. It has an LCD display, an alphanumeric keypad that makes it easy for the user to operate the TPRS. It can be interfaced with the PC for data analysis. It has a capability of storing up to 8000 test results.
- Polaris software - A Real time Bill Audit / Check Meter System installed at the industry, to check the correctness of utility bill, identify peak demand and trace penalty.
- Raspberry Pi which is an advanced board it contains Wi-Fi and 1GB RAM and here we use python language so memory is needed it has ARM 7 Processor, so it is also called as a small computer. It has a specific window using this we have a transmitter in the board so no need for external transistor using Wi-Fi we can send the information to cloud..
- Energy Meter- OPAL is a hand held computer used to download data from electronic tri-vector meters, supporting different protocols like IEC, ANSI and PACT. OPAL can be interfaced with portable printer for Spot Billing applications. OPAL comes with Linux Operating system. OPAL is available with memory sizes ranging from 128 MB to 8 GB. The products were explained to a limit which was very much appropriate to the time limit given to them.

Further we went to their seminar hall for another lecture given by one of their company named Mr. Goutham, which was quite very informative. The day ended with filling the feedback forms which had an option of attending their company again for college projects help, job preparation help, internship etc with focus on bridging the gap between the university curriculum and industry's requirement for ready to design engineers and offers a complete end to end revenue protection service which was a bonus point which impressed us a lot. We would definitely make use of such opportunity in future. As we thank our management, Vice Chancellor, Registrar, HOD and staff to arrange for us such an informative Industrial Visit.

P. Prakash
Staff In charges 21/9/2018

[Signature]
21/9/18

[Signature]
HOD / IT 21/9/18

Photographs of Industrial Visit on IOT in SANDS Pvt. Ltd. On 20.09.2018

The students had a demo session on different components like Raspberry Pi and Arduino in different sectors of industry.



Later we were taken to see their company owned products. They gave explanation to each of their products one by one. The products were

TPRS-1107 (three phase reference standard meter) is portable equipment. The main objective of this device is to calibrate the errors in three-phase and single-phase energy meters i.e. the meter under test (MUT).

The TPRS supports both static and electro-mechanical types of meters. It can also be used to compute the voltage, current, energy, power factor etc of the meter under test. It has an LCD display, an alphanumeric keypad that makes it easy for the user to operate the TPRS. It can be interfaced with the PC for data analysis. It has a capability of storing up to 8000 test results.

Polaris software - A Real time Bill Audit / Check Meter System installed at the industry, to check the correctness of utility bill, identify peak demand and trace penalty.

Raspberry Pi which is an advanced board it contains Wi-Fi and 1GB RAM and here we use python language so memory is needed it has ARM 7 Processor, so it is also called as a small computer



Industrial Visit on IIOT & BIGDATA

on

25-10-2018

SIGNALS & SYSTEMS (INDIA) PVT. LTD.

SANDS[®]





SHAKKEERA L <lshakeera@crescent.education>

Approval for Industrial visit for Crescent University on 25th October, 2018 at 10.00am

Surenadar Marketing-Training [Sands] <mktg.trg@sandsindia.com>

Mon, Oct 1, 2018 at 3:12 PM

To: lshakeera@crescent.education

Cc: Training Sands <sandstraining@sandsindia.com>, Site office Training <training@sandsindia.com>, "P Karthik Venkatesh [Sands]" <p.karthikvenkatesh@sandsindia.com>, Prabhakar K <prabhakar.k@sandsindia.com>, mktg Sands <mktg.sands@sandsindia.com>

Dear Ms. L.Shakeera,

Greetings From SANDS!!!

With reference to the trailing mail, We herewith **Approve** the **Industrial visit for the total maximum 75 students from 2nd & 3rd Year B.Tech. IT Dept., along with 3 to 4 Staff's Members from B.S.A. Crescent Institute of Science & technology, on 25th Oct 2018 (Thursday)**
Your Timing shall be from 10:00 am to 11:30am (1 1/2 Hrs only)

The exposure shall be mainly in **IIOT & BIGDATA** for your Students.

Program Schedule:-

- 1) Introduction to Industry & **SANDS** Products,
- 2) Introduction to Internet of Things & Big Data.
- 3) **SANDS** Product demo for 3-4 Nos for 5-7 minutes each
- 4) Discussion & Clarification about technology to students & Staffs
- 5) Tea Break
- 6) Departmental Visits

Please do call the undersigned for any further clarifications.

Kindly send your confirmation by mail.

Good day...

Thanks & Regards,

K.Surenadar
Marketing Engineer

The logo for SANDS (Signals & Systems) features the word "SANDS" in a bold, red, stylized font with a registered trademark symbol (®) to its upper right.

SIGNALS & SYSTEMS (India) Pvt. Ltd.

15/D-19, SIPCOT I.T Park, Siruseri, Chennai - 603103.

Mob: +91- 9003262765, 9841718045 (WhatsApp)

Landline : 044 - 27470001, 27470003, 27470087, 27470088

Email: mktg.trg@sandsindia.com

Website : www.sandsindia.com
www.sandscerebro.com

On Thu, Sep 27, 2018 at 2:30 PM Shakkeera <lshakeera@crescent.education> wrote:

Dear Sir,

As per the telephonic conversation regarding the industrial visit to SANDS (India) Pvt. Ltd, Chennai, now we are conforming the industrial visit date on 25th October, 2018 at 10.30am. Kindly arrange half day visit at company premises itself. As per our Head of the Department instruction, we are combining both second and third year students.

The following are the student's information regarding the visit.

Programme - B.Tech (IT)
Year of Study - Second & Third Year
No. of students - 70 - 80 students
No. of faculties - 3-4

Thanks & Regards

Ms.L.Shakkeera, B.Tech., M.E, (Ph.D).
Assistant Professor(Senior Grade)
Department of Information Technology
School of Computer, Information and Mathematical Sciences
BSA Crescent Institute of Science and Technology, Vandalur, Chennai-48.
Mobile No: +91-9444710836
Office No: +91-44-22751347 (Ext-234)



B.S. Abdur Rahman
Crescent
Institute of Science & Technology
Deemed to be University u/s 3 of the UGC Act, 1956
GST Road, Vandalur, Chennai 600 048

DEPARTMENT OF INFORMATION TECHNOLOGY

INDUSTRIAL VISIT – SANDS (India) Pvt., Ltd

STUDENT'S NAME LIST

S.NO	RRN	STUDENT NAME	PROGRAMME & BRANCH & SEMESTER
1.	160081601001	ABDUL HALEEM A	B.TECH – IT & V SEM
2.	160081601002	ABISHEK R	B.TECH – IT & V SEM
3.	160081601003	AHAMED ASIF S	B.TECH – IT & V SEM
4.	160081601004	AMEENUL MUTHALIFF	B.TECH – IT & V SEM
5.	160081601006	ASHWIN G	B.TECH – IT & V SEM
6.	160081601007	ATHIBA M	B.TECH – IT & V SEM
7.	160081601008	BHUVANESWARI S	B.TECH – IT & V SEM
8.	160081601009	CHITRA K	B.TECH – IT & V SEM
9.	160081601010	DEVANANTH A B	B.TECH – IT & V SEM
10.	160081601011	DINESH RAJ E	B.TECH – IT & V SEM
11.	160081601012	DIVYA K	B.TECH – IT & V SEM
12.	160081601013	FAIZAL HUSSAIN J	B.TECH – IT & V SEM
13.	160081601014	IMRAN M	B.TECH – IT & V SEM
14.	160081601016	JUDI GRACE RAJ S	B.TECH – IT & V SEM
15.	160081601018	KAMAL SHERIFF A K	B.TECH – IT & V SEM
16.	160081601019	KARTHEKEYAN M N	B.TECH – IT & V SEM
17.	160081601020	KIRAN R	B.TECH – IT & V SEM
18.	160081601022	MD SEHAN ISMAIL K	B.TECH – IT & V SEM
19.	160081601023	MISHAL FATHIMA S H	B.TECH – IT & V SEM
20.	160081601024	MOHAMED AFZAL KASIM	B.TECH – IT & V SEM
21.	160081601025	MD ARSHAD ARSALAN	B.TECH – IT & V SEM

22.	160081601026	MOHAMED AZEEM M A	B.TECH – IT & V SEM
23.	160081601027	MOHAMED JASIM HUSSAIN S	B.TECH – IT & V SEM
24.	160081601028	MOHAMED MOOSA Z	B.TECH – IT & V SEM
25.	160081601029	MOHAMED NAVEETH	B.TECH – IT & V SEM
26.	160081601030	MOHAMED SAFITH S	B.TECH – IT & V SEM
27.	160081601031	MOHAMED SAHED AFRIDI H	B.TECH – IT & V SEM
28.	160081601032	MOHAMED SYED SAJID H	B.TECH – IT & V SEM
29.	160081601033	MOHAMED YASAR ARABATE N	B.TECH – IT & V SEM
30.	160081601034	MOHAMED ZAKIR HUSSAIN S M	B.TECH – IT & V SEM
31.	160081601035	MOHAMMED ARSHAD FAROOQ A	B.TECH – IT & V SEM
32.	160081601036	MOHAMMED FIROZE	B.TECH – IT & V SEM
33.	160081601037	MOHAMMED RIYAS SUDEEN A	B.TECH – IT & V SEM
34.	160081601038	MURSHID M R	B.TECH – IT & V SEM
35.	160081601040	NIVEDHA R	B.TECH – IT & V SEM
36.	160081601041	NIZAR AHAMED J	B.TECH – IT & V SEM
37.	160081601042	RAHUL R	B.TECH – IT & V SEM
38.	160081601043	RAMAKRISHNAN NARASIMHAN	B.TECH – IT & V SEM
39.	160081601044	ROHITHA S M	B.TECH – IT & V SEM
40.	160081601045	ROSHAN S	B.TECH – IT & V SEM
41.	160081601046	SANJAY R	B.TECH – IT & V SEM
42.	160081601049	SITHAARTHAN D	B.TECH – IT & V SEM
43.	160081601050	SOUNDHARI N	B.TECH – IT & V SEM
44.	160081601051	SWETHA S B	B.TECH – IT & V SEM
45.	160081601053	VARSHA A	B.TECH – IT & V SEM
46.	160081601054	ASMA ZAINUL	B.TECH – IT & V SEM
47.	160081601055	NEAIKAR MD ASEEL	B.TECH – IT & V SEM
48.	160081601056	RIFASH.B	B.TECH – IT & V SEM
49.	160081601057	RIYAZ MUHAMMAD.N	B.TECH – IT & V SEM

50.	160081601058	MOHAMED ASLAM A.	B.TECH – IT & V SEM
51.	160081601059	MOHAMED SHAHLYN	B.TECH – IT & V SEM
52.	160081601060	GOMATHI D	B.TECH – IT & V SEM
53.	160081601061	MOHAMMED THOUSEEF	B.TECH – IT & V SEM
54.	160081602002	MOHAMED AJAZ A	B.TECH – IT & V SEM
55.	120081601008	AYESHA NAAZ	B.TECH – IT & V SEM
56.	160081601052	TAMILSELVAN D	B.TECH – IT & III SEM
57.	170081601002	AFIFA AMEEN SAHARIAH	B.TECH – IT & III SEM
58.	170081601003	AMJATH HUSSAIN .A	B.TECH – IT & III SEM
59.	170081601004	ARIVAN S K	B.TECH – IT & III SEM
60.	170081601005	ARUN J	B.TECH – IT & III SEM
61.	170081601006	ASHHVATH K	B.TECH – IT & III SEM
62.	170081601007	AZARAF ALI . S	B.TECH – IT & III SEM
63.	170081601008	AZRAH SHEHREEN. A	B.TECH – IT & III SEM
64.	170081601009	BHAGHIYASHRI AKSHARA .V	B.TECH – IT & III SEM
65.	170081601010	BHARATH KUMAR K	B.TECH – IT & III SEM
66.	170081601011	BHUVANESWARI.M	B.TECH – IT & III SEM
67.	170081601012	DEEPAK J	B.TECH – IT & III SEM
68.	170081601013	DEEPTHA MALIKA M	B.TECH – IT & III SEM
69.	170081601014	DILIP HAMILTON .V	B.TECH – IT & III SEM
70.	170081601015	HARINI R	B.TECH – IT & III SEM
71.	170081601016	HARSHENI. S	B.TECH – IT & III SEM
72.	170081601017	JEEVITHA.S	B.TECH – IT & III SEM
73.	170081601018	KAVIBHARATHI K	B.TECH – IT & III SEM
74.	170081601019	MADHAVAN S	B.TECH – IT & III SEM
75.	170081601021	MOHAMED AZARUDEEN	B.TECH – IT & III SEM
76.	170081601023	MOHAMED IMAZ. T	B.TECH – IT & III SEM
77.	170081601024	MOHAMED MUBARAK. H	B.TECH – IT & III SEM

78.	170081601025	MOHAMMED ARHAM K	B.TECH – IT & III SEM
79.	170081601027	MOHAMMED TAUQEER C.	B.TECH – IT & III SEM
80.	170081601030	NIZARUDEEN J	B.TECH – IT & III SEM
81.	170081601032	RAHIMANKHAN.E	B.TECH – IT & III SEM
82.	170081601033	RAJA MEENAKSHI.V	B.TECH – IT & III SEM
83.	170081601034	RAMDEEPAK R.	B.TECH – IT & III SEM
84.	170081601035	SAQUIB NAWAZ	B.TECH – IT & III SEM
85.	170081601036	SRIPREETHI S K	B.TECH – IT & III SEM
86.	170081601037	SYED SUHEL AHAMED .S	B.TECH – IT & III SEM
87.	170081601038	VARUN KUMAR K	B.TECH – IT & III SEM
88.	170081601040	ARVIND BHARANI	B.TECH – IT & III SEM
89.	170081601041	NOORJEHAN BEGUM A	B.TECH – IT & III SEM
90.	170081601042	HISHAM MOHAMED H	B.TECH – IT & III SEM
91.	170081601043	MOHAMED PAREES B.	B.TECH – IT & III SEM
92.	170081601044	MOHAMED ASIF ALI A	B.TECH – IT & III SEM
93.	170081602001	VAISHNAVI. M	B.TECH – IT & III SEM

 Faculty In-Charge
 (L. Shakkeera)

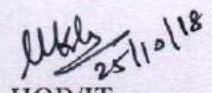
 HOD/IT
 (Dr. M. Kabeer)



DEPARTMENT OF INFORMATION TECHNOLOGY
INDUSTRIAL VISIT REPORT

The Department of Information Technology has arranged the Industrial Visit Programme to SANDS (Signals & Systems (India) Pvt. Ltd., SIPCOT IT Park, Siruseri, Chennai which is arranged on 25th October, 2018. Maximum 75 students from B.Tech (IT) – second and third year students are attended the industrial visit programme.

The main focus is on IIOT & Big Data Analytics concepts. The company was very impressive with its huge and attractive infrastructure. As we entered there, they started the lecture with a video clip about machine learning which was very interesting to watch. Later we were taken to see their company owned products. The overall programme schedule are,

- Introduction to Industry & SANDS Products
- Introduction to Internet of Things & Big Data
- SANDS Product demo
- Departmental visits

The products were,

- ✓ TPRS-1107 (three phase reference standard meter) is portable equipment. The main objective of this device is to calibrate the errors in three-phase and single-phase energy meters i.e. the meter under test (MUT). The TPRS supports both static and electro-mechanical types of meters. It can also be used to compute the voltage, current, energy, power factor etc of the meter under test. It has an LCD display, an alphanumeric keypad that makes it easy for the user to operate the TPRS. It can be interfaced with the PC for data analysis. It has a capability of storing up to 8000 test results.
- ✓ Polaris software - A Real time Bill Audit / Check Meter System installed at the industry, to check the correctness of utility bill, identify peak demand and trace penalty.
- ✓ Raspberry Pi which is an advanced board it contains Wi-Fi and 1GB RAM and here we use python language so memory is needed it has ARM 7 Processor, so it is also called as a small computer. It has a specific window using this we has a transmitter in the board so no need for external transistor using Wi-Fi we can send the information to cloud..
- ✓ Energy Meter- OPAL is a hand held computer used to download data from electronic tri-vector meters, supporting different protocols like IEC, ANSI and PACT. OPAL can be interfaced with portable printer for Spot Billing applications. OPAL comes with Linux Operating system. OPAL is available with memory sizes ranging from 128 MB to 8 GB. The products were explained to a limit which was very much appropriate to the time limit given to them.

The day ended with filling the feedback forms which had an option of attending their company again for college projects help, job preparation help, internship etc with focus on bridging the gap between the university curriculum and industry's requirement for ready to design engineers and offers a complete end to end revenue protection service which was a bonus point which impressed us a lot. We would definitely make use of such opportunity in future. As we thank our management, Vice Chancellor, Registrar, HOD and staffs to arrange for us such an informative Industrial Visit.

Staff In charges

(L. Sheebheera)

HOD/IT

Photos - Industrial Visit on IIOT & BIGDATA
on
25-10-2018





INDUSTRIAL VISIT REPORT

ONE DAY INDUSTRIAL VISIT

AT

METTUR THERMAL POWER STATION (MTPS)

SALEM



Submitted by

In partial fulfilment for the award of the degree

Of

MASTER OF TECHNOLOGY

IN

**CONSTRUCTION ENGINEERING AND PROJECT
MANAGEMENT**



B.S. Abdur Rahman
Crescent

Institute of Science & Technology
Deemed to be University u/s 3 of the UGC Act, 1956

MARCH 2019

TABLE OF CONTENTS

ACKNOWLEDGEMENT	I
DECLARATION	II
ABSTRACT	III
LIST OF TABLES	IV
LIST OF FIGURES	IV

S.NO	TITLE	PAGE NO
CHAPTER -1		
1.	INTRODUCTION	1
1.1	THREE MAJOR INPUTS TO POWER STATION	2
1.2	FUNCTIONAL DESCRIPTION	3
1.2.1	FAMILARIZATION WITH PLANT BOILER	4
1.3	ELECTRICITY FROM COAL	7
1.3.1	COAL TO STEAM	7
1.3.2	STEAM TO MECHANICAL POWER	8
1.3.3	SWITCHING AND TRANSMISSION	
CHAPTER-2		
2	STEAM TURBINE	10
2.1	GENERAL DESCRIPTIONS	10

2.2	DESIGN FEATURES	10
2.2.1	BARREL TYPE HIGH PRESSURE TURBINE	11
2.2.2	INTERMEDIATE PRESSURE TURBINE	12
2.2.3	LOW PRESSURE (LP) TURBINE	12
3	COAL CIRCULATION	14
3.1	GENERAL DESCRIPTION	14
3.2	WORKING	14
3.2.1	CIRCULATORY SYSTEM	14
3.2.2	DRAFT SYSTEM	15
4	WATER CIRCULATION SYSTEM	15
5	CONDENSER	16
6	ELECTROSTATIC PRECIPITATOR	16
6.1	WORKING PRINCIPLE	16
6.2	GENERAL DESCRIPTION	17
7	DUST COLLECTING HOPPER WITH PNEUMATIC SYSTEM & SLURRY PUMP	17
7.1	RAPPING MECHANISM	17
7.2	SPECIFICATION	17
7.3	GAS DISTRIBUTION SYSTEM	18
8	ASH HANDLING SYSTEM	18
8.1	WET DEASHING SYSTEM	18

9	WATER CLARIFIER	18
9.1	D.M PLANT	19
10	CHIMNEY	19
10.1	FLY ASH AND FLUE GAS CONDITIONING	19
CHAPTER- 3		
	CONCLUSION	20

LIST OF TABLES

S.NO	TITLE	PAGE NO
1.1	RECORD OF CONTINUOUS RUNNING UNITS	2
2.1	HIGH PRESSURE TURBINE FEATURES	11
2.2	INTERMEDIATE PRESSURE (IP) TURBINE FEATURES	12
2.3	LOW PRESSURE (LP) TURBINE FEATURES	12
2.4	TURBINE SPECIFICATIONS	13

LIST OF FIGURES

S.NO	TITLE	PAGE NO
1.1	METTUR THERMAL POWER PLANT	1
1.2	PLANT MODEL	3
1.3	TYPICAL WORKING LAYOUT OF THERMAL POWER PLANT	4
1.4	ARRANGEMENT OF COOLING TOWER	5
1.5	COOLING TOWER	6
1.6	POWER TRANSMISSION	9
2.1	TURBINE	11
2.2	COAL HANDLING PLANT- COAL MILL	14
2.3	CONDENSER	16

ACKNOWLEDGEMENT

We would like to thank the entire **TANGEDCO**, and **MTPS** who has provided us this Industrial visit.

We thankful to **Dr. VASANTHI PADMANABHAN, Professor and Dean, School of Infrastructure, Department of Civil Engineering**, who gave us permission for industrial visit and **DR. K. YOGESWARI, Associate professor** who organized our industrial visit and also to **G. PRIYANTH Assistant professor** for their benevolent guidance throughout our visit.

We also thanks to the workers of their respective stations, who were guided and ready to clarify our doubts and also helped us to increase our knowledge by illustrating us to the finer points.

We hope that our report will reflect our technical knowledge which we learned at Mettur Thermal Power Station, Salem.

ABSTRACT

A thermal power station is a power plant in which the prime mover is steam driven. Water is heated, turns into steam and spins a steam turbine which drives an electrical generator. After it passes through the turbine, the steam is condensed in a condenser and recycled to where it was heated; this is known as a Rankine cycle. The greatest variation in the design of thermal power stations is due to the different fuel sources. Some prefer to use the term energy center because such facilities convert forms of heat energy into electricity. Some thermal power plants also deliver heat energy for industrial purposes, for district heating, or for desalination of water as well as delivering electrical power. A large part of human CO₂ emissions comes from fossil fuelled thermal power plants; efforts to reduce these outputs are various and widespread. At present 54.09% or 93918.38 MW of total electricity production in India is from Coal Based Thermal Power Station. A coal based thermal power plant converts the chemical energy of the coal into electrical energy. This is achieved by raising the steam in the boilers, expanding it through the turbine and coupling the turbines to the generators which converts mechanical energy into electrical energy.

CHAPTER -1

1. INTRODUCTION

This is the first inland Thermal Power Station of Tamil Nadu Generation and Distribution Corporation Limited (TANGEDCO Ltd.). The plant is located on the left flank of the Ellis surplus course of Mettur Reservoir. It is situated at an altitude of +212 mts, above MSL. The first unit was commissioned on 07.01.87 and the other 3 units were commissioned on 01.12.1987, 22.03.1989 and 27.03.1990 respectively. The boilers of the Mettur thermal Power Station-I, capable of producing 700 tonnes of steam per hour at 5400C and 137 kg/cm² pressure were supplied by M/s. BHEL, Trichy. The Turbo Generators were supplied by M/s.BHEL, Haridwar. The turbine is a three stage turbine and the generator is capable of generating 210 MW cost of Rs. 384.30 crores at a generation voltage of 15.75 kV. The second stage consists of units III &IV of 210 M.W each at a cost of Rs.351.76 crores. All the four units are coal based. Chimney of 220m Height to take care of environmental and ecological needs. State of art Distributed Control System for process control in Units I, II, III & IV. From Talcher Collieries in Odisha State. Also imported coal is being received from Indonesia. 4 Nos. Wagon tippers unload the coal wagons. A dyke has been constructed across the Perumpallam valley which consists of two settling ponds in series. Most of the ash is collected as Dry Ash in cylos and issued to cement companies. The power generated at 15.75 kV is stepped up to 230 kV by 3 phase 250 MVA transformer (one for each unit) and fed into the Tamil Nadu grid. All the four Units of Mettur Thermal Power Station–I were in continuous Operation for 73 days – a Unique Record in TANGEDCO History. Unit III of Mettur Thermal Power Station –I was in continuous operation for 337 days – a Unique Record in TANGEDCO History.



Figure 1.1 Mettur Thermal Power Plant

The project cost of Mettur Thermal Power Station –II (1x600 MW) is Rs. 3550 Crores. The construction of Mettur Thermal Power Project – Stage – III started on 25.06.08 and the Unit was first Synchronized with Grid on 4.5.2012. The trial run operation was carried out from 14.09.2013 to 12.10.2013 with 72 hrs full load (600 MW) Operation from 05.10.2013 to 08.10.2013. The Commercial Operation Date (COD) for MTPS –II (1x600 MW) was declared on 12.10.2013. Coal for MTPS - II is received from Mahanadhi coal fields Limited (Talchar & IB Valley), Orissa, Eastern coal fields Limited. Maximum Generation and Plant load factor (PLF) for the year 2015-16 is 3925.86 MU and 74.49 % respectively. The Maximum number of continuous running days for MTPS –II (1X600 MW) is 193 days. (From 03.10 2016 to 15.4.2017).

TABLE. 1.1 RECORD OF CONTINUOUS RUNNING UNITS

STATION/STAGE	UNIT	NO. OF DAYS
MTPS-I	Station record	73
MTPS-I/I	Unit I	259
	Unit II	205
MTPS-I/II	Unit III	337
	Unit IV	311

1.1 THREE MAJOR INPUTS TO POWER STATION:

1) Water

Water has been taken from nearby Cauvery Canal. This water is lifted by raw water pumps and is sent to clarifier to remove turbidity of water. The clear water is sent to water treatment plant, cooling water system and service water system. The water is de-mineralized (DM) by water treatment plant. The DM water is stored in condensate storage tanks from where it is used in boiler

2) Fuel Oil

The fuel oil used is of two types: (a) Low sulphur high stock oil (LSHS) (b) High speed diesel oil (HSD) The high speed diesel oil reaches the power station through the lorry tankers. The oil is stored in large tanks for the future use in the boiler. Heavy oil is stored in storage tanks in oil storage yard and is conveyed to the front through a set of pumps and strainers. The whole length of piping from the boiler front in stream traced to maintain the temperature and hence its fluidity so that it can freely flow in the pipelines.

3) Coal

The coal reaches the plant in the railways wagons. The unloading of coal is done mechanically by tilting the wagons by tippler. The coal is sent to the coal storage yard through the conveyor belts. The crushed coal from store is sent to the mill bunkers through conveyor belts. The air which takes away the coal dust passes upward into the classifier where the direction of flow is changed abruptly. This causes the coarse particle in the air coal stream to finer coal dust along with the primary air leaves the classifier onto the coal transport piping from where it goes to nozzle. Pulverized coal obtained from coal mill cannot be burnt directly.

1.2 FUNCTIONAL DESCRIPTION

The Thermal Power Station burns fuel & uses the resultant to make the steam, which drives the turbo generator. The Fuel i.e. coal is burnt in pulverized form. The pressure energy of the steam produce is converted into mechanical energy with the help of turbine. The mechanical energy is fed to the generator where the magnet rotate inside a set of stator winding & thus electricity is produced in India 65% of total power is generated by thermal power stations. To understand the working of the Thermal Power Station plant, we can divide the whole process into following parts.

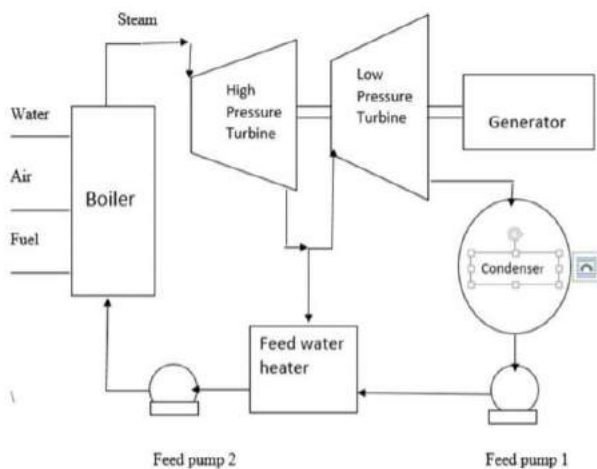

Figure 1.2. Plant Model

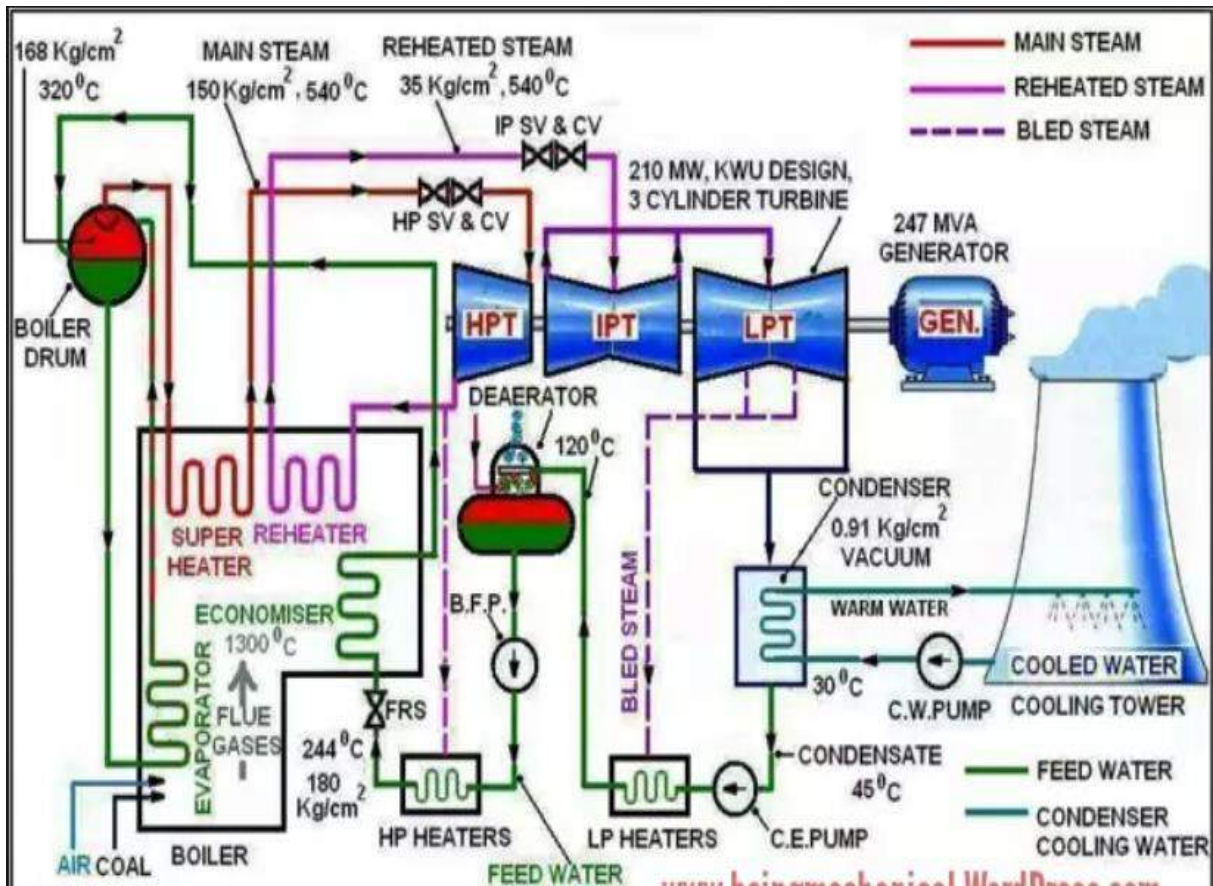

Figure.1.3 Typical Working Layout of Thermal Power Plant

1.2.1 Familiarization with Plant Boiler:

Boiler is a device used for producing steam. There are two types of boilers:

- a). Fire tube boiler
- b). Water tube boiler here, boiler used is of water tube type.

In the boiler, heat energy transfer takes place through tube walls and drum. The gases lose their heat to water in the boiler or superheated. The escape heat is used to heat the water through economizer. ID and FD fans are used to produce artificial draught. The fuel oil is used to ignite the boiler and pulverized coal is lifted from the coal mills by PA fans.

1.2.1.1 Turbine & Generator (TG)

Turbine is form of heat engine in which available heat energy in the form of steam is converted into kinetic energy to rotate the turbine by steam expansion in suitable shaped nozzles In Thermal

Power Station there are reaction turbines. The turbine consists of three stages: high pressure, intermediate pressure and low pressure. Steam enters the turbine at 350oC with maximum allowable temp. Of 545oC. Cold reheat steam goes to boiler, reheated at 540oC, then fed to medium pressure parts of the turbine. Then, after cooling it goes to hot well. The shaft is coupled with generator. The generator converts the kinetic energy of the rotating shaft to electric energy. Field windings are excited by D.C. power using exciter. Shaft of generator rotates at 3000 rpm speed.

1.2.1.2 Condenser

In condenser, the water passes through various tubes and steam passes through a chamber containing a large number of water tubes (about 20000). The steam gets converted into water droplets, when steam comes in contact with water tubes. The condensate is used again in boiler as it is dematerialized water and 5-6 heats the water, which was in tubes, during the process of condensation. This water is sent to cooling tower.

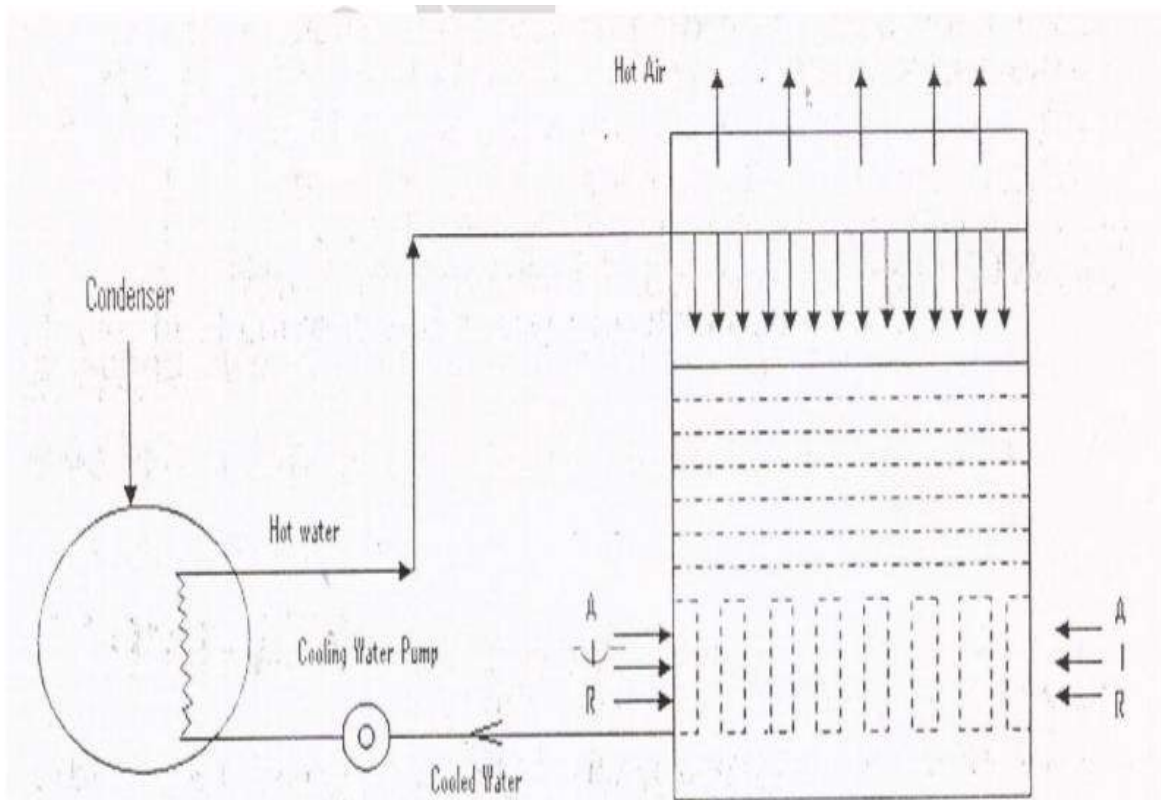

Figure 1.4 Arrangement of Cooling Tower

1.2.1.3 Cooling Tower

It is a structure of height 110m designed to cool the water by natural draught. The cross sectional area is less at the center just to create low pressure so that the air can lift up due to natural draught and can carry heat from spherical drops. The upper portion is also diverging for increasing the efficiency of cooling tower. Hence it is named as natural draught cooling tower.

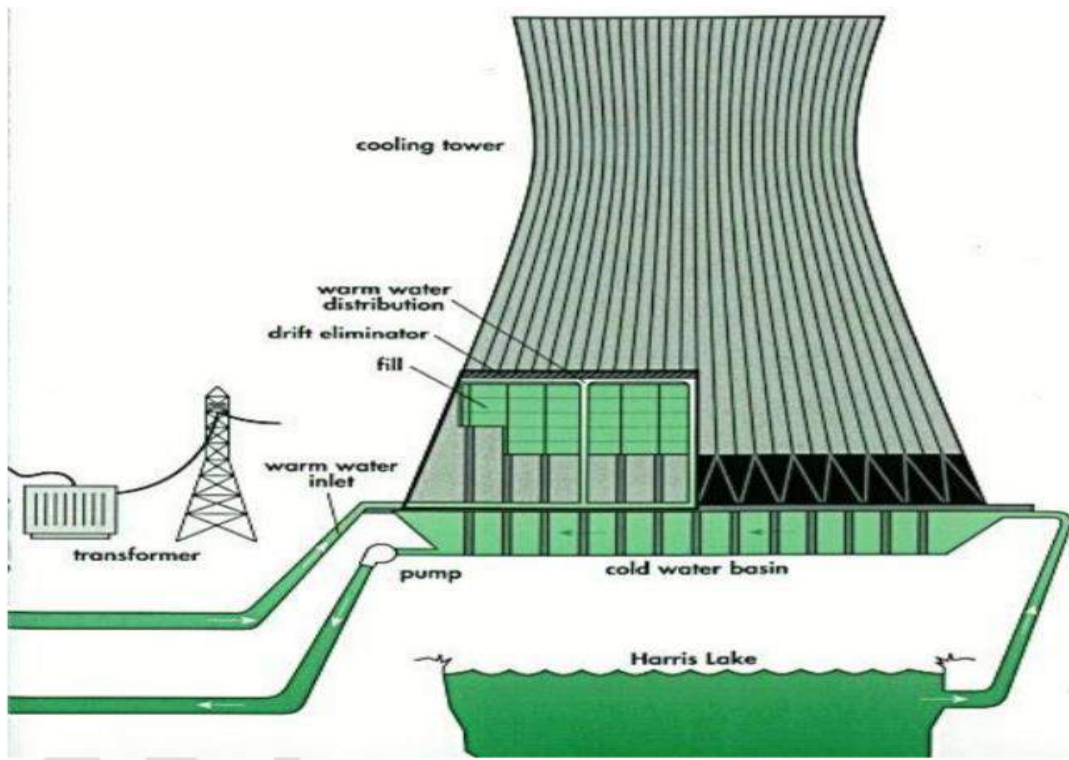

Figure 1.5 cooling tower

1.2.1.4 Electrostatic Precipitator

It is an electronic device, which removes the ash particles from the smoke through furnace of boiler. It helps in prevention of air pollution. It works on the principle that a charged particle is attracted towards opposite charge. When the fly ash comes between the opposites charged plates it gets charged and is attracted towards the plates and then collected from the plates by the discharging particles

1.2.1.5 Ash Handling Plant

Ash is not discharged as such to pollute the land, air and water, but slurry of ash is made in ash handling plant and this slurry is dumped in the wasteland, kept for the purpose.

1.2.1.6 Switch Yard

Switchyard is the area, which feed the grid supply to the station transformer and feeds the grid by the power generator by the unit. The power supply control is administrated here and the units consumed and supplies are recorded in the control room. The connections of 220KV BUS to the station transformer is done by using the isolated and gas filled circuit breakers.

1.3 ELECTRICITY FROM COAL

Electric power generation takes place in the following steps:

1. Coal to steam
2. Steam to mechanical power
3. Switching and transmission

1.3.1 COAL TO STEAM

The boiler burns pulverized coal at rates up to 200 tons per hour. From the coal store, fuel is carried on a conveyor belt and discharged by means of a coal tipper into the bunker. It then falls through a weighed into the coalpulverizing mill where it is ground to a powder as fine as flour. Air is drawn from the top of the boiler house by the forced draught fan and passed through the air preheaters to the hot air duct. From here some of the air passes directly to the burners and the remainder is taken through the primary air fan to the pulverizing mill, where it is mixed with the powdered coal, blowing it along pipes to the burners of the furnace. Here it mixes with the rest of the air and burns with great heat. The boiler consists of a large number of tubes and the heat produced raises the temp. Of the water circulating in them to create steam, which passes to the steam drum at very high pressure. The steam is then heated further in the super heater and fed through outlet valve to the high pr. cylinder of the steam turbine.

When the steam has been through the first cylinder (high pr.) of the turbine, it is returned to the repeater of the boiler and reheated before being passed through the other cylinders (intermediate and low pr.) of the turbine. From the turbine the steam passes into a condenser to be turned back into water 'condensate'. This is pumped through feed heaters where it may be heated to about 250oC to the economizer where the temp is raised sufficiently for the condensate to be returned to

the lower half of the steam drum of the boiler. The flue gases leaving the boiler are used to reheat the condensate in the economizer and then pass through the air pre-heaters to the electro-static precipitator. Finally they are drawn by the induced draught fan into the main flue and to the chimney.

1.3.2 STEAM TO MECHANICAL POWER

From the boiler, a steam pipe conveys steam to the turbine through a stop valve and through control valves that automatically regulate the supply of steam of the turbine, Stop valve and control valves are located in a steam chest and a governor, driven from the main turbine shaft, operates the control valves to regulate the amount of steam used. The steam leaving the high pr. cylinder goes back to the boiler for reheating and is returned to the intermediate pr. cylinder. Here it passes through another series of stationary and moving blades. Finally, the steam is taken to the low pr. cylinder each of which it enters at the center flowing outwards in opposite directions through the rows of turbine blades- an arrangement known as double flow-to the extremities of the cylinder. As the steam gives up its heat energy to drive the turbine, its temp falls and it expands. The turbine shaft rotates at 3000 rpm at 50 Hz. The turbine shaft drives the generator to generate alternating current.

When as much energy as possible has been extracted from the steam it is exhausted directly to the condenser. This runs the length of the low pr. part of the turbine and may be beneath or on either side of it. From the condenser, the condensate is pumped through low pr. feed heaters by the extraction pump, after which its pr. is raised to boiler pr. by the boiler feed pump. It passed through further feed heaters to the economizer and the boiler for recon version into steam.

1.3.3 SWITCHING AND TRANSMISSION

The electricity is usually produced in the stator windings of the large modern generators at about 25,000 volts and is fed through terminal connections to one side of a generator transformer that steps up the voltage 132000, 220000 or 400000 volts. From here conductors carry it to a series of three switches comprising an isolator, a circuit breaker and another isolator. The circuit breaker, which is a heavy-duty switch capable of operating in a fraction of a second, is used to switch off the current flowing to the transmission lines. Once the current has been interrupted the isolators can be opened. These isolate the circuit breaker from all outside electrical sources. From the circuit breaker the current is taken to the bus bars-conductors, which run the length of the switching

compound and then to another circuit breaker with its associated isolates before feeding to the grid. Three wires are used in a 'three-phase' system for large power transmission. The center of the power station is the control room. Here engineers monitor the output of electricity, supervising and controlling the operation of the generating plant and high voltage switch gear and directing power to the grid system as required.



Figure 1.6 Power Transmission

CHAPTER -2

2. STEAM TURBINE

The steam turbine is a prime mover that converts the stored mechanical energy in steam into rotational mechanical energy. A turbine pair consists of a ring of fixed blade and a ring of moving blades. The blades are so designed that the steam glides over the blade surface without striking it. As the steam flows over the curved surface of blade, it exerts a pressure on the blade along its whole length owing to its centrifugal force. The motive force on the blade will be the resultant of the centrifugal pressures on the blade length plus the effect of change of the steam as it flows over the blade

2.1 GENERAL DESCRIPTION

The turbine consists of three casings, high, medium and low pressure. HP part consists of two horizontally split casings-inner is placed inside, outer casing with scope for expansion in all direction. Fixed point of inner casing in the axial directions is between the nozzle chambers. Medium low pressure casing is split horizontally and comprise of 3 parts connected by vertical flanges. The outlet branches are connected rigidly with condenser which is supported on springs. In the middle casing, tube nests of 1st and 2nd LP heaters are mounted. The casings are interconnected by guide keys and fixed points in the axial direction is at the central part of the LP casing. Total thermal expansion of the casings is indicated at front bearing pedestal and is approximately 25mm when casings are fully stretched at rated steam parameters and at full load. The displacement of the bearing pedestal; between HP & MP parts is about 15mm. Relative expansion of rotors also are measured at 3 points.

2.2 DESIGN FEATURES

The turbine is of tandem compound design with separate High Pressure (HP), Intermediate Pressure (IP) and Low Pressure (LP) cylinders. The HP turbine is of Single Flow type while IP and LP turbines are of Double Flow type. The turbine is condensing type with single reheat. It is basically engineered on reaction principle with throttle governing. The stages are arranged in HP, IP and LP turbines driving alternating current full capacity turbo generator. The design and

constructional features have proved their reliability in service and ensure trouble free operation over long operating periods and at the same time ensuring high thermal efficiencies.



Figure. 2.1 Turbine

2.2.1 Barrel type High Pressure (HP) Turbine

The outer casing of the HP turbine is of barrel type construction without any massive horizontal flange. This unique construction permits rapid startup from any thermal state and high rates of load changes of the turbo set. The barrel type outer casing does not cause any problems during overhauls and capital maintenance as the assemble and disassembly of the turbine can be done in a relatively short time as compared to the conventional design. The HP turbine is of single flow type with 25 reaction stages.

TABLE.2.1 HIGH PRESSURE TURBINE FEATURES

Inlet Temperature	535°C.
Outlet Temperature	343°C.
Inlet pressure	150 Kg/cm ² .
Outlet Pressure	49 Kg/cm ² .

2.2.2 INTERMEDIATE PRESSURE (IP) TURBINE

The IP turbine is double flow type with horizontal split, inner casing being kinematically supported within the outer casing. It has 20 reaction stages. IP inner and outer casings as well as LP inner casing are suspended from top halves to totally eliminate the effect of TG centerline with the heating of the flanges. Although the casings are of horizontal split design yet these do not impose any constraints in startup timings and rapid load fluctuations.

TABLE. 2.2 INTERMEDIATE PRESSURE (IP) TURBINE FEATURES

Inlet Temperature	535°C
Outlet Temperature	340°C
Inlet pressure	37 Kg/cm ²
Outlet Pressure	7 Kg/cm ²

2.2.3 LOW PRESSURE (LP) TURBINE

LP turbine is also double flow type with exhaust area optimally selected for the expected vacuum conditions. It has 8 reaction stages per flow. Special design measures have been adopted to remove the moisture from the last stages by reducing the thickness of water film on the guide blades. The horizontally split, fabricated LP casing is comprised of three shells. The bearing pedestals are mounted on the foundation. Freestanding blades have been envisaged. The blades are designed to operate in the speed range corresponding to 47.5 Hz to 51.5 Hz grid frequency.

TABLE. 2.3 LOW PRESSURE (LP) TURBINE FEATURES

Inlet Temperature	360°C
Outlet Temperature	45°C
Inlet pressure	7 Kg/cm ²
Outlet Pressure	0.85 Kg/cm ²

TABLE 2.4 TURBINE SPECIFICATIONS

Make	BHEL
Rated Speed	3000 rpm
Rated Power	110 MW
Weight of HP Rotor	5500 Kg.
Weight of MP Rotor	11000 Kg.
Weight of LP Rotor	24000 Kg.
Steam Pr. (rated)	
Initial Steam	130 ata
Before MP casing	31.63 ata
Steam Temp. (rated)	
Initial Stem	535°C
IP Cylinder Stop Valve Inlet	535°C
HP Cylinder Exhaust	343°C
LP Cylinder Exhaust	49°C
Turning Gear Speed	62 rpm
Type of Turbine	
HP cylinder	
Regulating stage	Two rows Curtis wheel
Other impulse stage	8 Nos.
MP cylinder	
Impulse stage	12 Nos.
LP body	
Impulse stage	4 Nos.
Oil Supply	
Oil Tank rated Capacity	12500 Lt.
For oil system of generator	4400 Lt.

3. COAL CIRCULATION

3.1 GENERAL DESCRIPTION

Coal mills are mainly used to crush the coal. It crushes the coal in powder form. The powder form of coal is known as sream.

3.2 WORKING

Coal coming from CHM to coal bunker, which in small feed able parts. RC feeder control the feeds of the coal in the mill, three roller crushed the coal like as sream (as a powder form). Hot air supplied by PA fan help to crush the coal & cold air maintain temp. Gear present at the bottom is prevent the jamming by giving motion to the powder coal. PA fan maintain sufficient transfer pressure & the coal from 4 outlet pipe is given to the furnace.



Figure 2.2 Coal Handling Plant –Coal Mill

3.2.1 CIRCULATORY SYSTEM

Coal is transported from the coal mine with the help of train. Train wagons are emptied with the help of tippler and stored in coal yard. From here it goes to the coal crusher, where the big size coal is crushed and made into the required size. From coal crusher it goes to the coal bunker through conveyor belt and from coal bunker it move to R.C. feeder. R.C. feeder feeds coal to the coal mill, where the coal is ground into powder form. Air from primary air fan is introduced into

the coal mill and coal powder mixed with it and goes to the classifier. The work of classifier is just to separate the un pulverized coal and feed. It again to the coal mill. The pulverized coal mixed with air enters in the furnace at the corner through and forms a circle due to tangential fired. Here coal burns completely and releases heat and becomes in ash form. Ash in the furnace is taken away by ID fan through the Electrostatic precipitator. The purpose E.S.P. is to collect the ash. From the E.S.P. ash goes to the ash handling plant. The particles of ash which are not collected in the E.S.P. are goes to atmosphere through the chimney.

3.2.2 DRAFT SYSTEM

The force needed to draw air is called as draft. This force may be due to small pressure difference in the stream of flue gases or in the air which cause the flow to take place. In mechanical draft system, there are two type of application namely force draft & balance drafting. At P.T.P.S. balance draft system is used. Two fans are employed, one termed force draft other termed as induced draft fan. The F.D. fan is utilized to force atmospheric air into the furnace and then it is function of ID fan to such out the boiler flue gases through the economizer, air pre heater etc. & discharging it out through the stack. There two working together maintain a balance draft which is normally slightly negative pressure in the furnace.

4. WATER CIRCULATION SYSTEM

In this system the water is delivered to a system generation from heaters at a temperature well below the saturation value corresponding to that pressure. Thus the hydrostatic head available will not be able to overcome the frictional resistance for a flow corresponding to the minimum requirement of cooling of water wall tubes. Therefore natural circulation to boiler is limited to pressure of 175 g/cm² and in our case this pressure is about 138 kg/cm² and hence natural circulation system is sufficient. The process describes the effect produced by addition of a alum to the colloidal suspended dispersion resulting in particle destabilization by a reduction force which lend to keep particle apart. Rapid mixing which is done in flash mixer in the clarifloculation is done to obtain uniform dispersion. Second stage of formation of particle from destabilized colloidal fixed particle is termed as 'flocculation'. The D.M. water is obtained by ion exchange process. The filtered water is first passed through cation exchanger process where the cations of dissolved impurities are removed. Then it is passed to the degassifier tower where most of CO₂ is removed. Thus the pure D.M. water is obtained which is stored in the storage tanks for makeup.

During the process of D.M. cation and anions resins get discharge and have to be reactivated with the help of HCL and caustic soda D.M. of water is done to prevent the scale sludge formation problem in the boiler drum which restricts the transfer of head of water.

5. CONDENSER

The steam after working in the turbine is condensed in condenser in each unit installed below the LP exhaust. The condenser is of surface type made of fabricated construction in single shell. The tube is of divided type double pass arrangement, having two independent cooling water inlet, outlet and reserve and water boxes. The condenser is provided with integral air-cooling zone at the center from where air and non-condensable gases are continuously drawn out with the help of mechanical vacuum pump. The condensate is collected at the bottom portion of the condenser called the hot well from where it is pumped up to the deaerator by the condensate pumps through the different heating stages. The function of the condenser is to condense the out coming steam from LP turbine. In the condenser cooling water flows through the tubes and exhaust steam from the turbine outside the pipes.



Figure 2.3 Condenser

6. ELECTROSTATIC PRECIPITATOR

Electrostatic Precipitator (ESP) is equipment, which utilizes an intense electric force to separate the suspended particle from the flue gases. In India coal is widely used to generate power. The exhaust gases from the furnace contains large amount of smoke and dust. If these gases are emitted directly into the atmosphere, it will cause great environmental problems. So it is necessary to extract this

dust and smoke before emitting the exhaust gases into atmosphere. There are various methods of extracting dust but electrostatic precipitator is the most widely used. It involves electric charging of suspended particles, collection of charge particles and removal of charged particles from collecting electrodes.

6.1 WORKING PRINCIPLE

The electrostatic precipitator utilizes electrostatic forces to separate dust particles from the gases to be cleaned. The gas is passed through a chamber, which contains steel plates (vertical) curtains. These steel curtains divide the chamber into number of parallel paths. The framework is held in place by four insulators, which insulate it electrically from all parts, which are grounded. A high voltage direct current is connected between the framework and the ground, thereby creating strong electric field between the wires in the framework curtains. The whole process is divided into the following parts: 1. Corona Generation. 2. Particle Charging. 3. Particle Collection. 4. Particle Removal.

6.2 GENERAL DESCRIPTION

The whole Electrostatic Precipitator is divided into following two parts:

- ♣ Mechanical System.
- ♣ Electrical System.

Mechanical system: Mechanical system comprises of Precipitator Casing, Hopper, Collecting and emitting system, and Rapping mechanism, Gas Distribution System.

7. DUST COLLECTING HOPPER WITH PNEUMATIC SYSTEM & SLURRY PUMP

7.1 RAPPING MECHANISM

During electrostatic precipitation a fraction of the dust will be collected on the discharge electrodes and the corona will be suppressed as the dust layer grows. So, rapping is done in order to remove this dust by hammering the electrodes.

7.2 SPECIFICATION

Voltage and Current 415V and 5Amp. Power and Speed 3.7KW and 710 rp

7.3 GAS DISTRIBUTION SYSTEM

The good performance of the ESP depends on even distribution of gas over entire cross section of field. Gas Distribution System distributes the gas evenly in ESP and maintains its efficiency.

8. ASH HANDLING SYSTEM

It is very important to control the ash coming from the furnace.

1. WET ASH HANDLING SYSTEM 2. DRY ASH HANDLING SYSTEM

A pipe line from ESP which contains the ash is divided in two parts. Use of Dry ash Evacuation instead of

8.1 WET DEASHING SYSTEM

Dry deashing system consumes less power & also minimizes waste reduction. The dry ash is directly transferred by vacuum system at desired place in plant it transfer to nearest cement factory. It acts as a good source of income for the plant. The wet ash is transferred to the wet ash handling, in this vacuum created by water flow. Ash mix with the water and transferred to the ash pump from there it is drain out from the plant in to the lake. From here it is given to the raw water storage. The ASH produced in the boiler is transported to ASH dump area by means of sluicing type hydraulic ASH handling system. This consists of bottom ash system. Ash water system, fly ash system, ash slurry system.

9. WATER CLARIFIER

It received impure water from raw water storage. In raw water storage big suspended particle settle down. CANAL – RAW WATER STORAGE – LAKE – WATER CLARIFIER In water clarifier the purification of raw water held in two process. 1. Coagulation 2. Chlorination

In coagulation, Potash alum is added in the water. In this process the fine suspended & colloidal particles are removed from water. In chlorination, chlorine gas is added to the water, which have disinfectant action & it kills the harmful bacteria, germs & destroyed the pathogenic microorganism. Excess of chlorine in water will effect to the taste of water.

9.1 D.M. PLANT

In the DM Plant the water is D-mineralized. The water is used for steam generation is must be free from colloidal & dissolved impurities. All the colloidal impurities are removed in the WATER CLARIFIER. Then the supplied to the DM Plant. Water clarifier – DM PLANT. Here the water contain dissolved impurities, which are mainly the salt of Ca, Na & Mg. It mainly sulphates & chloride etc CaSO_4 , NaCl , CaCl_2 etc. In the DM Water Ist sent to the Sand filter & rest of the colloidal impurities are removed.

10. CHIMNEY

The gases produced due to burning of coal are comes out from chimney. The height of chimney is designed with respect to the boiler layout. The temp is also maintained in the chimney. It is not more than 120 c. If it more than 120 c, then boiler will be corrupt.

10.1 FLY ASH AND FLUE GAS CONDITIONING

Flur gas and fly ash characteristics at the inlet define precipitator operation. The combination of flue gas analysis, flue gas temperature and fly ash chemistry provides the base for fly ash resistivity involves both surface and volume resistivity. As gas temperature increases, surface conductivity decreases and volume resistivity increases. In lower gas temperature ranges, surface conductivity predominates. The current passing through the precipated fly ash layer is conducted in a film of weak sulfuric acid on the surface of the particles. Formation of the acid film (from SO_3 & HO) is influenced by the surface chemistry of the fly ash particles. In higher gas temperature ranges, volume conductivity predominates. Current conduction through the bodies (volume) of the precipitated fly ash particles is governed by the total chemistry of the particles.

CHAPTER-3

CONCLUSION

This training focused upon increasing our knowledge and interest in toward the Production of Electricity using Coal as a primary source/fuel. Because Electricity is most efficient and necessary needs to peoples in these days so its production at most efficient method with minimum cost and in proper sequence with less wastage. We learnt how to produce it by turbine, generators, cooling towers, water and maintain it. It was a great experience. It increase our practical skills that's the main thing which we learnt in the training session. Thus, we believe that our training session will be beneficial for various purposes & hence our efforts will be fruitful.

DECLARATION

This report is based on the industrial visit we have undergone in the premises of Mettur Thermal Power Station (MTPS) - A unit of Tamilnadu Generation and Distribution Cooperation Co. Ltd. (TANGEDCO), on 7th March 2019. We obtained the knowledge of whole unit of mettur thermal power plant. The experience of the industrial visit was good and we learned lots of things.



Department of Aerospace Engineering

A report on Industrial visit to INS RAJALI

Duration : 25.09.2018 Students: 45

Airport type Naval Air Station

Operator Indian Navy

Location Arakkonam, Vellore, Tamil Nadu



INS Rajali is located at Arokanam, 90 km from Chennai in Tamil Nadu and was commissioned on 11 March 1992. The air station is home to INAS 312 Albatross which operates the Tu-142 maritime reconnaissance aircraft. The base also trains Chetak pilots at INAS 561 Rotors and a SAR (Search & Rescue) Chetak Flight of INAS 321 Angels also operates from here. Additionally, it also has the base support facility to cater for the maintenance of the Tu-142 aircraft. This station boasts of having the longest runway in India. Guarding the southern boundaries of the country, essentially the Palk Strait, is a non-commissioned aviation unit --> INS Rajali-II. Located at Ramnad, Tamil Nadu this airfield was established to operate Islander aircraft and Chetak helicopters for Operation Pawan. Presently the airfield is utilised only for helicopter operations undertaking patrol missions in Palk Bay.

Feedback from Students:

We visited INS Rajali on 25 September 2018 to obtain true aircraft industry experience and knowledge. The visit was really informative, as we saw many fighter aircraft flying, landing, getting repaired etc. we got the chance to learn about these things. There were so many divisions working for the naval station. We visited control room of naval station where all the instructions to aircraft is given from. They explained us about their working, how the instructions are given, what are codes of instruction. Then they took us to aircraft instruments museum available there, there we saw many instruments such as sonar, torpedo and other instruments. We got the chance to know about history of military aviation of our Country. Then we were taken to the ground.

Where many aircrafts were harbored. We saw military aircrafts like Tu-142, Boeing P-8I Neptune. We also were taught about the different components of these aircrafts such as engine, wings, landing gears etc. At the end we were taken to The Helicopter division where many helicopters were flying, landing and being repaired, we saw the repairing also they taught about the basic repairing of the helicopter engine. We had an informative talk with the pilot over there. He gave the complete details about the aircrafts and helicopters including flying, handling, combating etc.

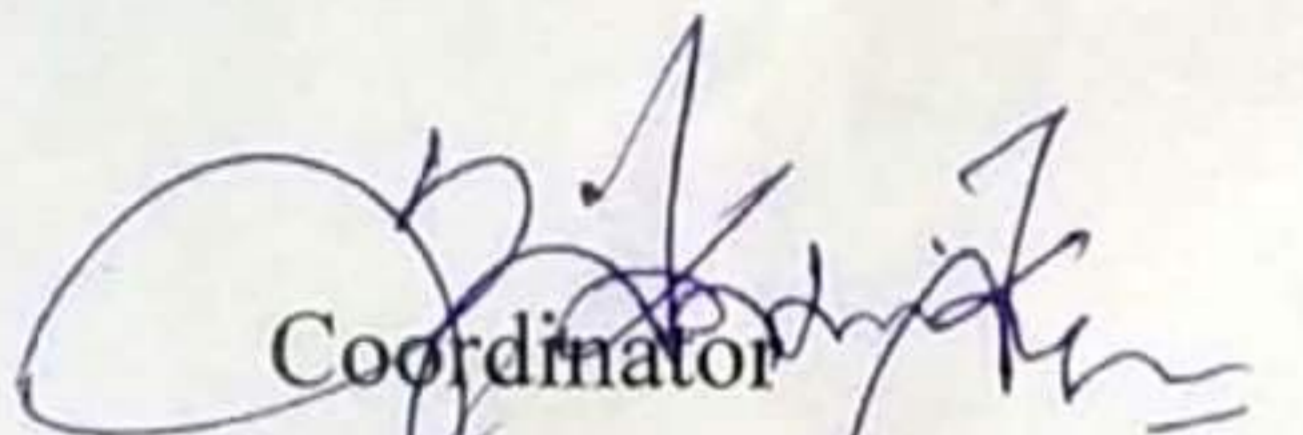
Coordinator
(S. KARTHKEYAN).

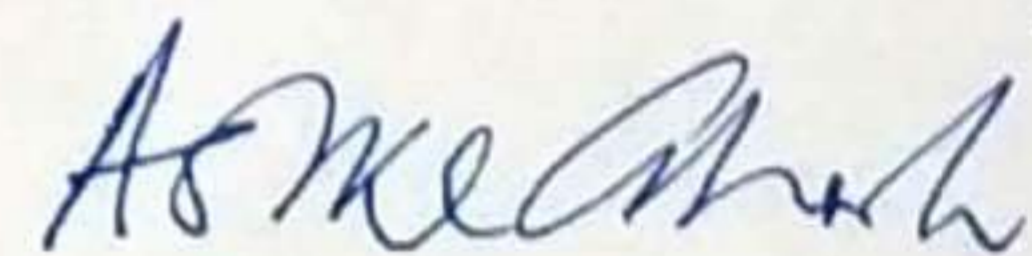

HoD/ Aerospace Engg.

Department of Aerospace Engineering
B.S. Abdur Rahman

Crescent
Institute of Science & Technology
Vandalur, Chennai-600 048.



Dean School of Mechanical Sciences

DEAN
School of Mechanical Sciences
B.S. Abdur Rahman
Crescent
Institute of Science & Technology
Vandalur, Chennai-600 048.

Date:- 10.04.2019

Automobile Students

11th year

Industrial visit

On 16.03.2019 we 33 students of automobile dept. went for industrial visit to Ashok Leyland, Ennore, Chennai.

INTRODUCTION

The Automobile faculty managed an industrial visit to a batch of 33 students of Automobile 11th year from Crescent Institute of Science and Technology. We all went to Ashok Leyland by college bus. It was located in Ennore at Chennai. We all students enjoyed a lot on the way.

In industry premises, first they gave us a brief introduction about the company and the rules to be followed during the visit. One person was assigned to co-ordinate and explain about various machines present over there. He helped us in clearing the doubts after explaining about the working of the things we saw.

We were able to understand the working of brakes with rear axle, manufacturing of engine blocks and total assembly of chassis. Finally we visited the testing of vehicle like chassis dynamometer, turning angle of a vehicle, speed test (Speed differentiating from 1st gear to last gear), turning angle.

It was so useful to us and thanks for arranging a wonderful industrial visit to us.

1. Dhanush S

4. M. Maheshwar

2. Anantha Krishnan S.P.

5. R. Nitish

3. Kaarthi C.R

Feedback

From,

A. MOHAMMED HAMMADH ALI

B.Tech Automobile

B.S Abdur Rahman Crescent
institute of Sci and tech.

18th Aug - 2018
Vandana

To,

THE HOD

Automobile department.

B.S Abdur Rahman Crescent
institute of Sci and tech.

On 18 - August - 2018, we the Students of IInd year Automobile engineering attended an industrial visit to Mando Automotive India Pvt Ltd, Irovingattukottai. we were assisted by our professors Mr. V. Depan and Mr. Manu Joseph. we were given 3 hours for the industrial which includes refreshments and lunch. Then we were divided into two groups and two technicians from Mando took us around the various section of the plant. we were given a brief explanation on making of breaks, suspension and steering systems. They explained us the whole process of manufacturing from raw material to finished products.

They explained their business models, tieups and their subsidiary companies. They showed as the importance of employees well beings through a short film which was motivational. we were able see high performance CNC machines. Finally we had a motivational speech and photo session.

A. MD HAMMADH ALI

(170121601034)



M. MAHESHWAR

(170121601022)



KARATHIC R

(170121601018)

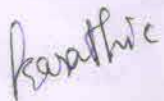

Field Visit

Industry visited: NURAY CHEMICALS PVT LTD

Date of visit: 08.03.2019

Introduction

Industrial visit is considered as one of the tactical methods of teaching. The main reason behind this- it lets student to know things practically through interaction, working methods and employment practices. Moreover, it gives exposure from academic point of view. Main aim industrial visit is to provide an exposure to students about practical working environment .They also provide students a good opportunity to gain full awareness about industrial practices. Through industrial visit students get awareness about new technologies. Technology development is a main factor, about which a students should have a good knowledge. Visiting different companies actually help students to build a good relationship with those companies. We know building relationship with companies always will always help to gain a good job in future. After visiting an industry students can gain a combined knowledge about both theory and practical. Students will be more concerned about earning a job after having an industrial visit.

A batch of 1st and 2nd M.Sc. Chemistry students (29+20) along with three faculty (Dr. NH, Dr. SB and Dr. NV) coordinators visited the Nuray Chemicals Private Ltd at Thiruvallur on 08.03.2019. This unit is mainly focusing on the preparation of raw materials for drugs (GRAMS)

List of students participated in the field trip are:

S. No	RRN	Name
1	180522601001	Abbas Ahamed. S
2	180522601002	Ahamed Riswan M.I.
3	180522601003	Banu. K
4	180522601004	Bhavadharini. S
5	180522601005	Dinesh. L
6	180522601006	Divya Bharathi R.
7	180522601007	Hemanathan. E
8	180522601008	Jeyachitra Devi. G
9	180522601009	Jotheeswar. S
10	180522601010	Joyce. K
11	180522601011	Kalpana C
12	180522601012	Kavi Priya S
13	180522601013	Mani Muthu Selvi. M
14	180522601014	Manimozhi K.M



Field Visit: A Report

15	180522601015	Monisha. S
16	180522601016	Mukesh E.
17	180522601017	Muthumani
18	180522601018	Parthiban N.
19	180522601019	Prithvi Raj D.
20	180522601020	Rachna Bhimkumar sharma
21	180522601021	Rajesh Kumar Pandit M
22	180522601022	Salman Faris K.
23	180522601023	Sandhiya Malathi M.
24	180522601024	Sandhiya. G
25	180522601025	Shruthi G
26	180522601026	Sivakumar S
27	180522601027	Sowmiya. P
28	180522601028	Syed Abbas. S
29	180522601029	Vidhya. N
30	170522601001	Anbarasan. S
31	170522601002	Anitha.R
32	170522601003	Bavithra. V
33	170522601006	Deepalakshmi. K
34	170522601008	Gokul Raj.S
35	170522601010	Jagadeeshwari. R
36	170522601011	Maheswari. M
37	170522601012	Muthu. R
38	170522601013	Pavithra. R
39	170522601015	Preethi Jayarani. J
40	170522601016	Revathi. R
41	170522601017	Saivinitha. R
42	170522601018	Swathi
43	170522601020	Vijay. M



Mr. Babu, Production incharge of Nuray Chemicals Pvt Ltd, addressed the students and introduced about the techniques they are implying in the production of raw material of drug. He also explained about the functioning of five different department in their company.

1. WARE HOUSE
2. PURCHASE
3. QC
4. R&D
5. AR&D

WARE HOUSE:

Here they store the goods (chemical) which are used in the production of raw materials of drugs. Here Liquids and solids are kept separately according to the temperature resistant.

PURCHASE DEPARTMENT:

This unit works on purchasing the required chemicals and also sales the produced raw materials to the customers (formulater).

QUALITY CONTROL:



Field Visit: A Report

Mr. Amara addressed the QC department, he also explained about the **wet analyser, HPLC**. This unit gives the quality assurance of the produced raw material in the company after checking its quality. This unit contains **GC, HPLC, UV, FTIR, STABILITY CHAMBER, PHOTO STABILITY CHAMBER**.

The expiry date of each and every raw material is fixed with the help of stability chamber.



R&D:

Mr. Madhukar addressed the R&D department in which small scale development is going on. This unit consists of overhead stirrers, glove box, rotary evaporators, magnetic stirrer, etc related to organic synthesis. The completion of reaction is cross checked with the help of TLC, HPLC and UV.



Brands of chemicals used:

- Rankem
- Sigma Aldrich
- Spectrochem

The role of **AR&D** is to support R&D



MANUFACTURING BLOCK-I:

The main process of manufacture takes place with the help of *stainless steel reactor*, *glass line reactor* and *centrifuge*. Basic compounds of raw materials are prepared with the help of stainless steel reactor whereas the acidic media of compounds will take place in glass line reactor. Centrifuge is used to separate the liquids and solids from the slurry. The chilling efficiency of temperature between -10°C and -50°C is achieved with means of methanol and water or glycol. This manufacturing process takes place in Nitrogen atm.



REMOVAL OF COLOUR:

The removal of colour from the raw material can be done with the help of carbon and the removal of carbon from the raw material can be done with the help of sparko filter.

MANUFACTURING BLOCK-II:

Field Visit: A Report

This unit consist of pressure reactor (hydrogenator reactor). This reactor is maintained at high pressure. Brine chillers (-10°C to -30°C) and Cooling towers (25°C to 30°C) are used to cool the reactor.



POWDER PROCESSING AREA:

The unit is highly restricted with a safety measure- ppe (personal protective equipment). This area consists of **dryers, multi millers, sewers**. This processing unit temperature maintained at 25°C with +/-3°C tolerance.

CONCLUSION:

Overall this field trip brought awareness and practical knowledge for the students about the various CRAMS, API type of drug development in industry. This also provided an opportunity for their future career in pharma industry.

Name and Signature of:

Dr. S. Bhagavathy
Staff Coordinator

Dr. D. Easwaramoorthy
HOD / Chemistry

Dr. S. Kutti Rani
Dean / SPCS

INDUSTRIAL VISIT REPORT

On 15th April 2019, We students and 2 faculty members went for Industrial visit to “Sakthi Engineers” manufacturing unit, Chromepet, Chennai.

Department of Chemistry, Chemistry faculty managed a industrial visit tour to 1st and 2nd year M.Sc students to “Sakthi Engineers” manufacturing unit by university bus. It was located in the interiors of Chromepet at Chennai. We all students enjoyed a lot on the way. In the unit premises, we met senior engineer of the unit, he was working there for past 9 years. He told us about every activity happening in the unit. He explained very clearly, that we were so interested to know more about the processes happening there. The unit was divided into two:- Mixing & preparation using raw materials. ; and Processing area.

THREADING:

The unit mainly collects old/used rubber rollers that is used for printing purposes. The used rollers were collected, recorded in their books and were given unique numbers (job numbers) according to their clients, from which they collected. Their important clients were “Thinathandi” and “Thinamalar” newspaper companies.



LINING:

The old rubber is scraped off from the bar and the bar is coated with liquids that holds the new rubber (to be rolled) strong. Further, thin wires are rolled over the bar, to avoid friction due to the oil/liquid applied. This process is “Lining”.



RAW MATERIALS AND MANUFACTURING OF RUBBER:

Rubber is manufactured using the raw materials in the other unit, which is 1 (or) 2 kms far. It is then rolled over the coated bar and is kept in the room temperature for few days. This rubber is so soft, that it is easily stretchable.



VULCANISATION:

Later, this newly rubber rolled bars are kept in the vulcanisation chamber, for 2 hours at 180°C temperature and 60 psi pressure with steam inlet. This makes the rubber strong and is

not easily stretchable. This process is known as “vulcanisation”. After vulcanisation, the rubber rollers/bars are kept at room temperature for 3-4 days.



ROUGHING:

After 4 days, these rubber rollers undergo “Roughing” process, where excess rubber is scraped -off.

While rolling rubber, they add 10mm extra rubber to the given size (length x breadth) so as to avoid shortage. This excess rubber is scraped-off during final steps.



GRINDING:

After roughing; the rubber rollers undergo “Grinding”, where the level of the rubber in the rollers is set perfectly, such that their surface is smooth.



POLISHING:

At last, the rubber rollers are polished with chalk powder and sand paper. This process is “Polilshing”.



Final checking of their softness is done and are packed for delivery to their respective customers. This whole process takes about a week or so, depending upon the electricity.

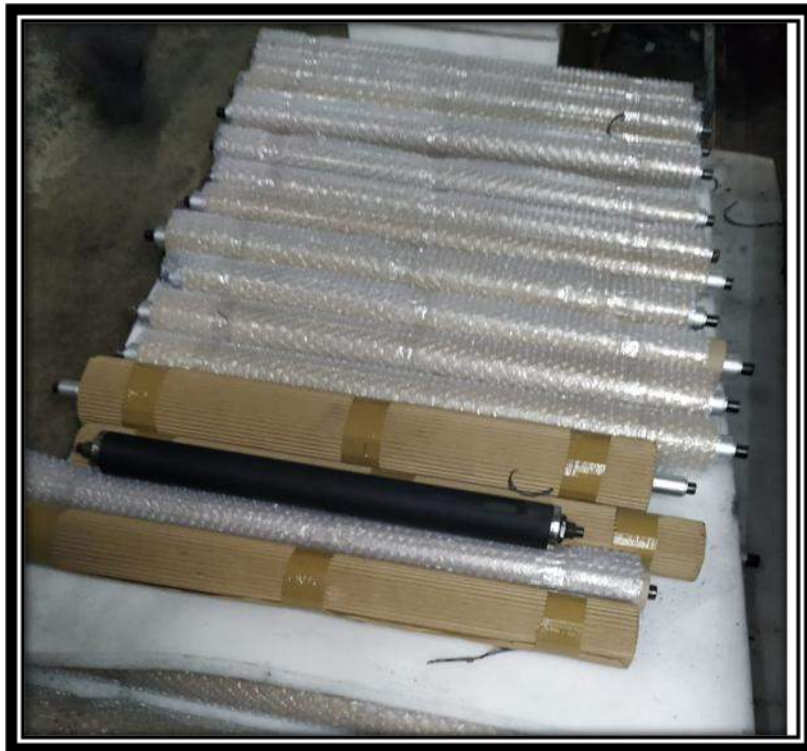

We all came back to college by 12:50pm noon from the industry.

ARUNGAL FIELD PROJECT REPORT

CRESCENT SCHOOL OF ARCHITECTURE – M.ARCH BATCH (2018-2020)

INTRODUCTION:

- Arungal Village, with population of 688 is Chengalpattu sub district's the 50th least populous village, located in Chengalpattu sub district of Kancheepuram district in the state Tamil Nadu in India.
- Total geographical area of Arungal village is 4 km² and it is the 55th biggest village by area in the sub district.
- Population density of the village is 162 persons per km².
- Nearest town of the village is Nandivaram - Guduvancheri and distance from Arungal village to Nandivaram - Guduvancheri is 7 km.
- Pin code of Arungal village is 603202.
- The village comes under Keerapakkam panchayat.
- Chengalpattu is the sub district head quarter and the distance from the village is 27 km.
- District head quarter of the village is Kancheepuram which is 63 km away. 1.69 square kilometer (40%) of the total village's area is covered by forest.

DEMOGRAPHICS:

- The village is home to 688 people, among them 351 (51%) are male and 337 (49%) are female. 91% of the whole population are from general caste, 9% are from schedule caste.
- Child (aged under 6 years) population of Arungal village is 12%, among them 54% are boys and 46% are girls. There are 172 households in the village and an average 4 persons live in every family.

GROWTH OF POPULATION:

- Population of the village has increased by 17.8% in last 10 years. In 2001 census total population here were 584.
- Female population growth rate of the village is 19.5% which is 3.3% higher than male population growth rate of 16.2%.
- General caste population has increased by 18.9%; Schedule caste population has increased by 8.5% and child population has increased by 75% in the village since last census.

LITERACY:

- Total 436 people in the village are literate, among them 242 are male and 194 are female.
- Literacy rate (children under 6 are excluded) of Arungal is 72%. 79% of male and 65% of female population are literate here.
- Overall literacy rate in the village has increased by 11%. Male literacy has gone up by 6% and female literacy rate has gone up by 16%.

WORKERS PROFILE:

- Arungal has 53% (366) population engaged in either main or marginal works.
- 64% male and 42% female population are working population.
- 52% of total male population are main (full time) workers and 12% are marginal (part time) workers.
- For women 23% of total female population are main and 19% are marginal workers

SEX RATIO - Females per 1000 Male

- As of 2011 census there are 960 females per 1000 male in the village.
- Sex ratio in general caste is 956, in schedule caste is 1000.
- There are 867 girls under 6 years of age per 1000 boys of the same age in the village.
- Overall sex ratio in the village has increased by 26 females per 1000 male during the years from 2001 to 2011. Child sex ratio here has increased by 212 girls per 1000 boys during the same time.

DATA:

ARUNGAL - 250 households

VAO - Josephine (Karanai)

CLERK - Leema (Keerapakkam / Vandalur)

ISSUES ARISED FROM – VAO:

- Bad roads because of reserve forest
- Poverty - agriculture based
- Most households don't have toilets
- No community toilets
- No government servants
- Elementary school
- EB connection there, except on "poromboke"
- Ground water and panchayat water

SITE SURVEY:

Survey carried out by 17 students on February for about 170 households to identify the problems and needs of that particular community.

Key Important Problems Listed Out Are:

1 - Transport 17% 2 - Clinic 11% 3 - Roadways 20% 4 - Pollution 6% 5 - House 4%
6 - Temple 3% 7 - Water tank 6% 8 - School 9% 9 - Library 4% 10 - Fuel station 4%
11 - Streetlights 5% 12 - Market 4% 13 - Signal tower 4% 14 - Electricity 1%
15 - Toilet 2% 16 - Park 1%

**CRESCENT SCHOOL OF ARCHITECTURE
ARUNGAL SURVEY
2019**

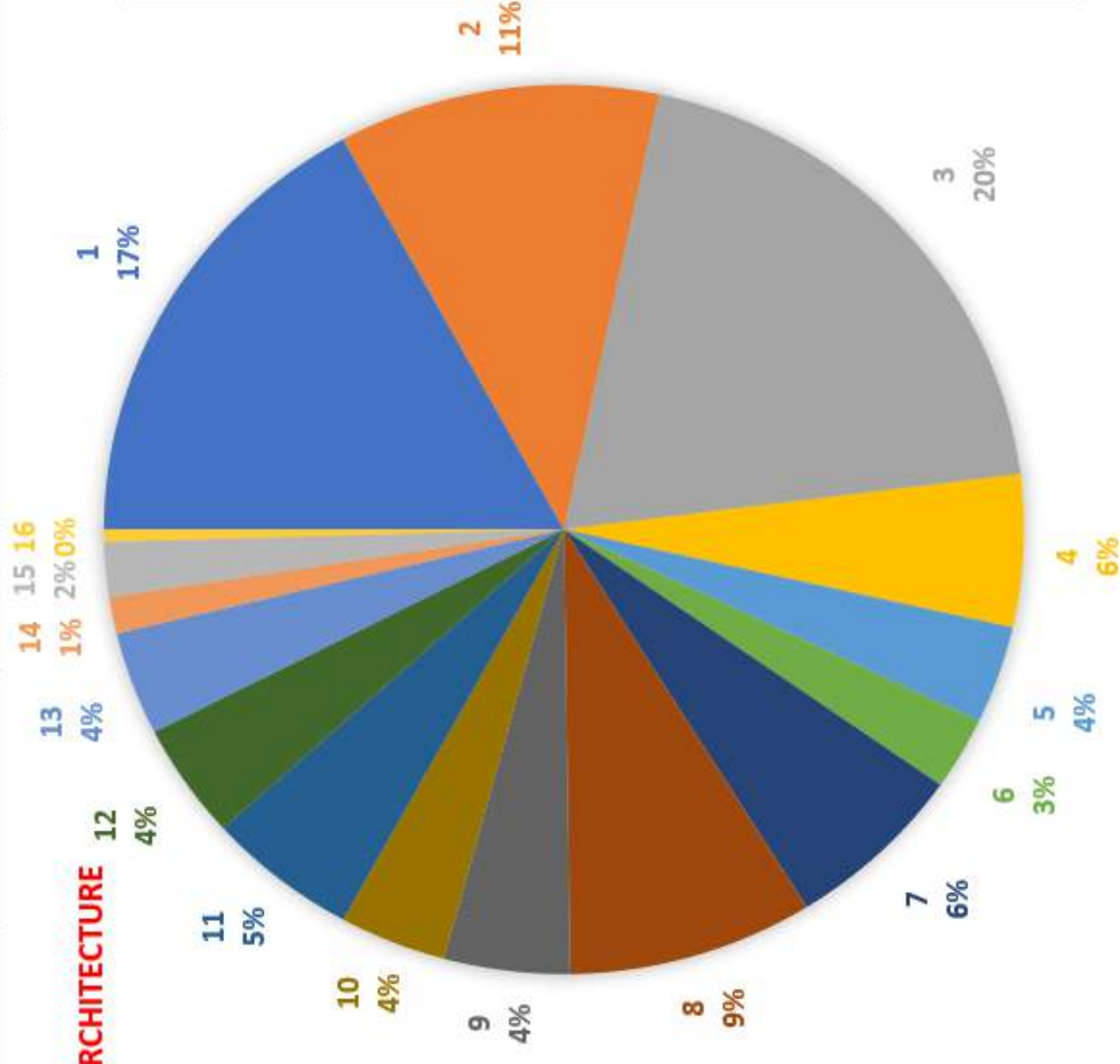

**From 170
Households:**

- 1 - Transport 17%
- 2 - Clinic 11%
- 3 - Roadways 20%
- 4 - Pollution 6%
- 5 - House 4%
- 6 - Temple 3%
- 7 - Watertank 6%
- 8 - School 9%
- 9 - Library 4%
- 10 - Fuel station 4%
- 11 - Streetlights 5%
- 12 - Market 4%
- 13 - Signaltower 4%
- 14 - Electricity 1%
- 15 - Toilet 2%
- 16 - Park 1%

SI.NO	RRN	NAME
1	180030101001	ARSAT ALI N
2	180030101002	CHANDRU A
3	180030101003	DHEEBAN RAJ A
4	180030101004	HASEENA NILOFER H
5	180030101005	INDHUSRI S
6	180030101006	JAYAKUMAR M
7	180030101007	JAYASHREE G
8	180030101008	KARTHICK S
9	180030101009	MD SALMAN KALEEM K
10	180030101010	OLIMARAN R
11	180030101011	PRAVEEN A G
12	180030101012	RAGUL D
13	180030101013	RAJESH R
14	180030101014	RAJMOHAN T N
15	180030101015	SIVA BALAKUMARAN B
16	180030101016	THANUJ T H
17	180030101017	YASHWANTH RAMKUMAR B

According to the needs of the people who reside there, the above mentioned students of Crescent School of Architecture studying M.Arch 1st year came up with different proposals as following.

ARUNGAL VILLAGE SURVEY

UNNAT BHARAT ABHIYAN (UBA) BASELINE HOUSEHOLD SURVEY

Arungal - Village Overview

Gram Panchayat :	Keerapakkam
Block / Tehsil :	Chengalpattu
District :	Kancheepuram
State :	Tamil Nadu
Pincode :	603202
Area :	425.03 hectares
Population :	688
Households :	172
Nearest Town :	Nandivaram - Guduvancheri (7 km)



Google Map of Arungal

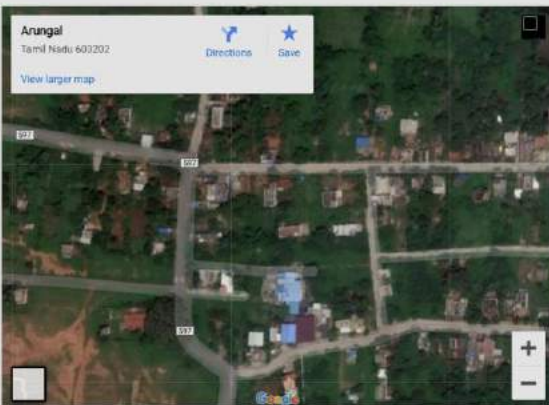

FOCUSED AREA

Population of Arungal

Total Population	Male Population	Female Population
688	351	337

Connectivity of Arungal

Type	Status
Public Bus Service	Available within 2 km distance
Private Bus Service	Available within 5 km distance
Railway Station	Available within 8 km distance

STREET ACTIVITIES



USING COMPOUNDS AS CLOTH HANGERS



WEAKER DISPLAY UNITS



NO PROPER SHADE



NO STORE AND NO STRUCTURE

ABOUT ARUNGAL

ACCORDING TO CENSUS 2011 INFORMATION THE LOCATION CODE OR VILLAGE CODE OF ARUNGAL VILLAGE IS 629409. ARUNGAL VILLAGE IS LOCATED IN CHENGALPATTU TEHSIL OF KANCHEEPURAM DISTRICT IN TAMIL NADU, INDIA. KANCHEEPURAM AND CHENGALPATTU ARE THE DISTRICT & SUB-DISTRICT HEADQUARTERS OF ARUNGAL VILLAGE RESPECTIVELY. AS PER 2009 STATS, KEERAPAKKAM IS THE GRAM PANCHAYAT OF ARUNGAL VILLAGE. THE TOTAL GEOGRAPHICAL AREA OF VILLAGE IS 425.03 HECTARES. ARUNGAL HAS A TOTAL POPULATION OF 688 PEOPLES. THERE ARE ABOUT 172 HOUSES IN ARUNGAL VILLAGE. NANDIVARAM - GUDUVANCHERI IS NEAREST TOWN TO ARUNGAL WHICH IS APPROXIMATELY 7KM AWAY.

BLOCK / TEHSIL → CHENGALPATTU
 DISTRICT → KANCHEEPURAM
 STATE → TAMIL NADU

WAY FINDING AND IMAGABILITY

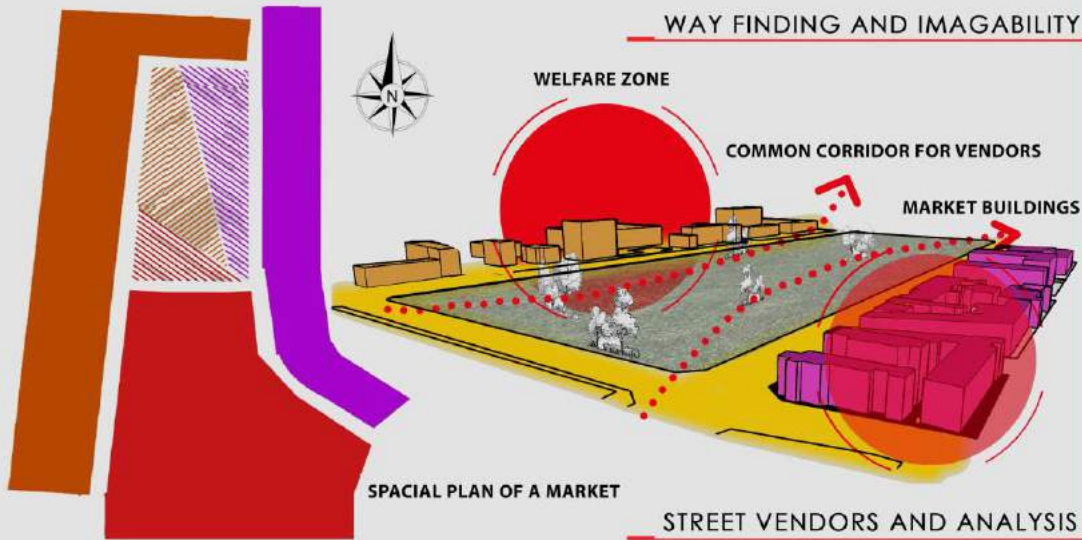

STREET VENDORS AND ANALYSIS

FAMILY SIZE OF STREET VENDORS

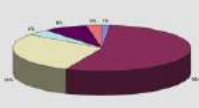

WORKING HOURS OF STREET VENDORS

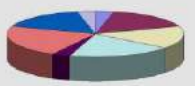

EDUCATION LEVEL OF STREET VENDORS

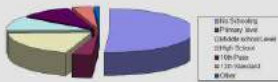

GENDER CLASSIFICATION

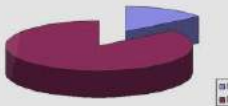

DIFFERENT LANGUAGES KNOWN BY STREET VENDORS

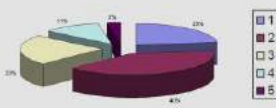

MODE OF TRAVEL TO REACH WORK PLACE

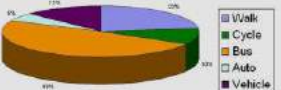

PROS	CONS
VARIED CULTURE AND CONSUMER BEHAVIOUR	VERY CONGESTED ROADS AND EXTREME DIFFICULTY IN VEHICULAR MOVEMENT
WIDE RANGE AND CHEAPER SELECTION	NO STORE WATER RUN OFFS OR DRAINAGE
AMONG SPACE ALLOTTED - NOT ENOUGH	NO STREET FURNITURES - FOR REST
CONVENIENT SHOPPING - ALL AT ONE	NO HYGIENE
	HIGH RISK OF THEFT
	PEDESTRIAN MOVEMENT DIFFICULT
	POORLY MAINTAINED

TYPE OF BUSINESS	PERCENTAGE
FRUITS OR VEGETABLES	8
FOODS	12
OUTS, PAN	8
BEVERAGES/DRINK	2
MEAL, CHAI	5
READY TO EAT	3
BOOKS/CRAFTS AND JEWELLERY	17
CLOTHING	48
OTHERS	3



ON A SCALE OF 1 - 10 WHICH LOCALITY IN BANGALORE HAS THE HIGHEST MARKETS



PERCENTAGE OF VENDORS GETTING AFFECTED BY ROAD WIDENING OR BY METRO

Examples of issues	Type of issues
Family tradition	Tradition
Handshakes from customers	No other choice
Fast money	Economic necessity/essential
Financial security	
No formal job opportunities	
Forced off land	
Options chosen for making money	Rational economic decision
Best way of making money	
Easy to set up	
Money comes in more than any other job	
Lack of cooperation from larger businesses	
Limited expertise required	
Low investment	

REASONS FOR THE VENDORS TO HAVE STALLS/STOPS IN THE LOCALITY

Goods



ANALYSIS OF THE BUYERS OVER TIME

Timing



ANALYSIS AND INFERENCE

- DRINKING WATER, A WASHROOM, AND CLEAN TOILETS ARE BASIC HUMAN NEEDS. EVERY MARKET SHOULD PROVIDE THESE FOR THE VENDORS.
- IN ADDITION, VENDORS NEED SHADE AND SHELTER TO PROTECT THEM AND THEIR GOODS FROM SUN, RAIN AND DUST, WASTE COLLECTION FACILITIES, AND STORAGE SO THEY DO NOT HAVE TO CARRY THEIR GOODS AWAY FROM THE MARKET EACH DAY.
- CUSTOMERS NEED GOOD PEDESTRIAN ACCESS AND PARKING.

IMPORTANT NODES



- 1) Balloon man
- 2) No storage and structure for vending on ground (display space 1.8 X 1.2 m)
- 3) Using compound wall as to display clothes
- 4) Small space required with platform selling flowers
- 5) Platform created with boxes, height is modified as per need
- 6) Temporary structure required with platform for bread seller
- 7) Selling fruits on moving cart with temporary weather protection (display space 1.8 X 1.05 m)
- 8) Cot and bed used to display
- 9) Designed rickshaw cart
- 10) Designed moving cart to sell ice-cream

THE DISTANCE TO MARKETS FROM ARUNGAL IS MINIMUM 5KM TO MAXIMUM 18KM AWAY FROM THE GIVEN AREA FOR THE VENDORS AND THE RESIDENTS. SINCE, THEY FIND THIS AS A VERY DIFFICULT WAY TO THEIR DAILY LIFE ROUTINE GIVING THEM A MARKET NEARER TO THE AREA WOULD BENEFIT THEM MORE IN EVERY WAY. ESPECIALLY IN ECONOMY AND STANDARDS THEY LL GET WELL VERSED.

- URAPAKKAM .1
- GUDUVANCHERY .2
- CHENGALPETTU .3
- TAMBARAM .4

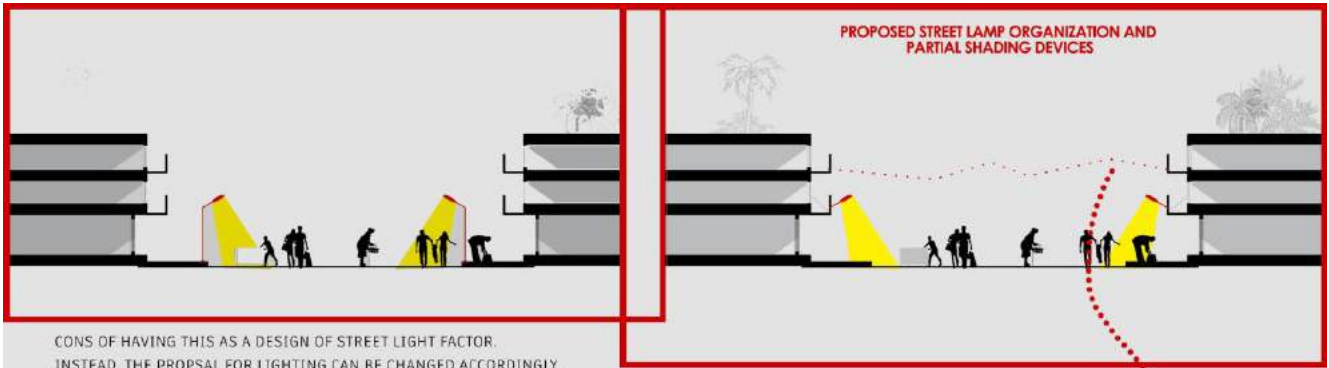

CONS OF HAVING THIS AS A DESIGN OF STREET LIGHT FACTOR. INSTEAD, THE PROPSAL FOR LIGHTING CAN BE CHANGED ACCORDINGLY.

SUGGESTING DURABLE, LONG LASTING JUTE SHADING DEVICES TO INCREASE THE THERMAL COMFORT



CONGESTION AND OBSTRUCTION

CLEAR CIRCULATION

LIGHT LAMPS AS A BARRIER

PROPOSED STREET LAMP ORGANIZATION

JUTE PARTIAL SHADING DEVICES



4. PARTICIPATORY DESIGN

STREET VENDORS HAVE INNOVATIVE IDEAS OF HOW SPACE CONFLICTS CAN BE RESOLVED, AND WHEN SECURED VENDING SPACE IS ASSURED MANY VENDOR ASSOCIATIONS CAN MANAGE THE VENDING SPACE. MANAGEMENT MAY INCLUDE, SPACE ALLOCATION, COLLECTION OF FEES OR LICENSE PAYMENTS, AND CLEANING AND LITTER COLLECTION. (GOVT SCHEME AND DESIGN A CENTRE)



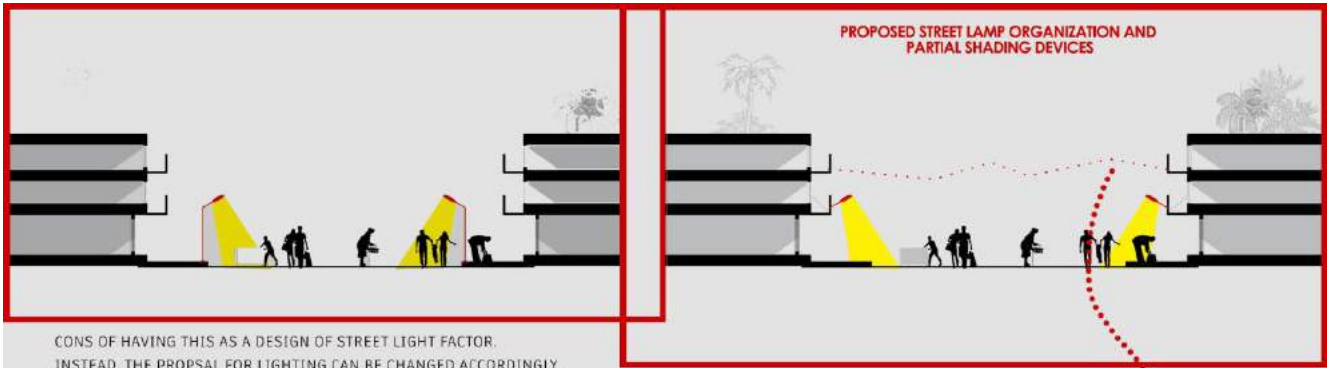

CONS OF HAVING THIS AS A DESIGN OF STREET LIGHT FACTOR. INSTEAD, THE PROPSAL FOR LIGHTING CAN BE CHANGED ACCORDINGLY.

SUGGESTING DURABLE, LONG LASTING JUTE SHADING DEVICES TO INCREASE THE THERMAL COMFORT



4. PARTICIPATORY DESIGN

STREET VENDORS HAVE INNOVATIVE IDEAS OF HOW SPACE CONFLICTS CAN BE RESOLVED, AND WHEN SECURED VENDING SPACE IS ASSURED MANY VENDOR ASSOCIATIONS CAN MANAGE THE VENDING SPACE. MANAGEMENT MAY INCLUDE, SPACE ALLOCATION, COLLECTION OF FEES OR LICENSE PAYMENTS, AND CLEANING AND LITTER COLLECTION. (GOVT SCHEME AND DESIGN A CENTRE)

A golf cart used for carrying the handicapped or elderly or pregnant woman around the market , so that they have an ease of convenience while shopping.

Pathways here are already provided for the pedestrians to walk , but since they were encroached by the vendors all the traffic came on to the street , the pathway instead of being used by the youngsters , are provided as the only vehicular movement for the physical challenged , pregnant women and the elderly , so that they too can shop with ease

the stalls would pitch in the pavement , hence claiming it to be their property , which caused more traffic

after removing the shed , the space becomes more clear visually as well hence creating a chance for better spaces

the pathways are broken and taken up by the shop keepers hence leaving no space for walking

SECTION DURING ENROACHMENT

the encroachment previously , has been turned into a pathway

SECTION AFTER PATHWAY

THE STREETS ARE PRONE TO FLOODING , DUE TO POOR PLANNING AND DRAINAGE

ARUNGAL STREETS TENDS TO GET EASILY FLOODED , HENCE THE METHOD OF CREATING A LITTLE SLOPE WHICH WILL DRAIN THE WATER TO THE PAVEMENT , UNDER WHICH THE DRAINS ARE PROVIDED

RE DEFINED HI-TECH MARKET STREET

TEAM 3: WATER MANAGEMENT PROPOSAL - RAJESH R & JAYASHREE G

UBA ARUNGAL
2019 WATER MANAGEMENT



LEGEND :

- MAJOR ROAD
- CEMENT ROAD
- MUD ROAD
- HOUSES
- WATER BODY
- PUBLIC BUILDINGS
- PROPOSED BUILDING

SITE DETAILS

Location : Arungal
District : Kanchipuram, TN, India
Pincode : 603202
Area : 425.03 hectares
(overall including farm lands)
Population : 688 (around 750 -2019)
Households : 172

(Source : general census 2015)

NEARBY VILLAGES:

Sonallur
Mambakkam
Keelakottiyur
Melakottiyur
Nallambakkam
Karanaipuducher
Kayarambedu
Perumathunallur
Keerappakkam
Murugamangalam

TOPOGRAPHY

The over all topography of the vilage is consist of average slopes sloping towards thr southwestern side along the major roadways

the heighest point of the vilage is near the public zone area which consist of a primary school, ration shop and a water tank on the west-ern side on the slope

CONNECTIVITY

Public Bus Service Available within 2 km distance

Private Bus Service Available within 5 km distance

Railway Station Available within 8 km distance

FINIDNGS IN SURVEY:

A Survey is carried out on Q1 of 2019 around 170 households all around the Arungal vilage .

Key Objective of the survey is to understand the situation of the vilagers and vilage , their necessary needs.

The data which is collected :

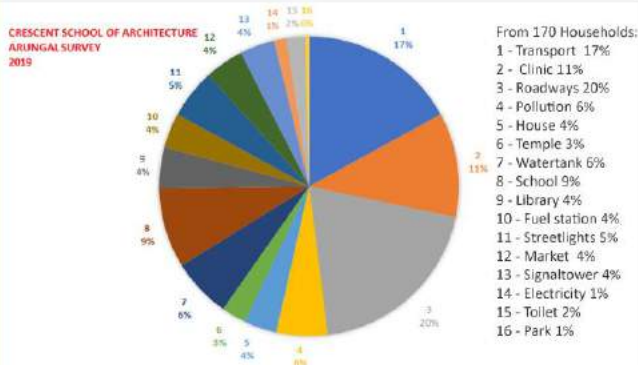

so, the important needs are transportation, watertanks,- school,lirary,market,park,sewage maintainance, clinic .

PROPOSAL :

Water tanks and water circulation :

The idea for the proposal is to increase the storage tanks of water for the whole vilage .

There is one existing water tank in arungal whihc is not suficient . hence proposal is ti improvise the water tank capacity and also providing another source of water from ground through borewell , secondly metro water which comes from guduvanchery town.

The proposal will include a eco friendly water treatment plant along with two large water tanks . At the highest point of the vilage by taking the topography and contour conditions .

Then a series of smaller tanks should be provided at the end or junction of two streets , since most of the house holds doesnt have a wel equiped water storage tank it is better to provide a sseperate smaller tanks at the end of their reach .



LEGEND :

- MAJOR ROAD
- CEMENT ROAD
- MUD ROAD
- HOUSES
- WATER BODY
- PUBLIC BUILDINGS
- WATER T BUILDING
- SMALL W. TANKS
- WATER TANK
- WATER LINE (approx.)

WATER TANK CAPACITY :

As per Rules : in city : 135 litres per person /day
 Total population :1000 (with future development in acc)
 Hence 1.3Lakh litres per day.

TANK CAPACITY :

2day storage = 2.6Lakh litres
 Sump Capacity : 2.6lakh Litres storage

Treatment plant to tank Thorough Electric motor (using solar panels to accumulate energy and transfer it to grid) minimize cost .

SOURCES OF WATER :

Water from Guduvanchery
 Bore well

WORKING PROCEDURE :

The water comes to the sump and then goes through eco-water treatment plant . From that it is sent to water tanks through means of motor then circulated to smaller tanks through gravitational

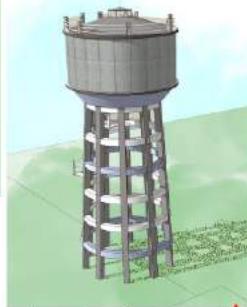

Large water tank - store treated water 1.3Lakh Litres



Sump and eco - Water Treatment plant and pump room



Water tank in each junction capacity : 4000 - 6000 litres



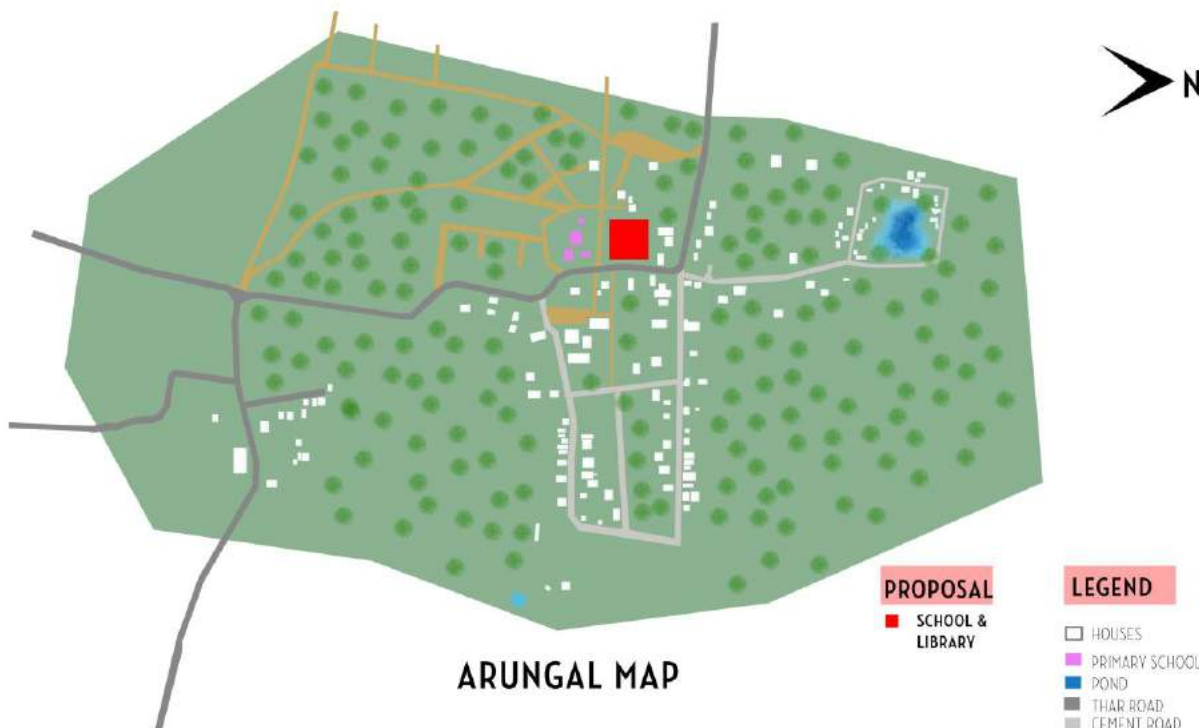

SITE DETAILS

SITE LOCATION- ARUNGAL
 CLIMATE- HOT AND HUMID
 GRAM PANCHAYAT- KEEDEPALLEM
 BLOCK/ TEHSIL- CHENGALPATTUR
 DISTRICT- KANCHI
 STATE- TAMIL NADU
 COUNTRY- INDIA
 PINCODE- 605002
 AREA- 4050 HECTARES
 POPULATION- 480
 HOUSEHOLDS- 102
 NEAREST TOWN- NANDIYASAM, GUDUVANCHERU

CONNECTIVITY OF ARUNGAL

TYPE STATUS
 PUBLIC BUS SERVICE- AVAILABLE WITHIN 2000 DISTANCE
 PRIVATE BUS SERVICE- AVAILABLE WITHIN 5 KM DISTANCE
 RAILWAY SECTION- AVAILABLE WITHIN 10 KM DISTANCE

NEARBY VILLAGES OF ARUNGAL

SEKKALUR
 KAMBESAPAI
 KELLAKOTTYUR
 NEELAKOTTYUR
 KALLAARAKKAM
 KUDAMURTHICHERI
 KATTAMBEDI
 PERUMATHIYALUR
 KELLAPPARAKKAM
 MURUGANPALLEM
 PUDUPALLEM

COLLEGES NEAR ARUNGAL

ACTHULAM INSTITUTE OF ENGINEERING
 MEENTH COLLEGE OF EDUCATION
 KUNDURAI COLLEGE OF EDUCATION
 SVN COLLEGE OF EDUCATION

GOVT HEALTH CENTERS NEAR ARUNGAL

0 SEMMANGUDI HEALTH SUB CENTRE- SEMMANGUDI, MADURAI
 25 VILANGUDI HEALTH SUB CENTRE- VILANGUDI, MADURAI
 SIVAS HOSPITAL - PASOOTTA, JENMANN ROAD- NEELAKOTTYUR COLLECTORATE OFFICE

PROPOSAL

LIBRARY

Libraries are seen by many as a lifeline and a crucial public service, especially if you are elderly, socially isolated, poor, vulnerable.

In rural areas, the local library, along with the village hall, and shop, is the focal point of community life. It's a safe, trusted place for meeting friends and neighbours, a place for learning, information and leisure and sometimes just a place to keep warm.

If a community is unfortunate enough not to have a static library, then mobile/ housebound services fill the gap, helping those that are most isolated.

HIGHER SECONDARY SCHOOL

This village already has a primary school, for the higher classes, they have to transport from the local body to another area.

This causes the difficulty for the students, thus if this village have a higher secondary school; these kind of problems will be solved.

Rural education is important not only for the enhancement of life quality of the rural community, but also for the overall progress and development of the country.



PRIMARY SCHOOL



RATION SHOP

ARUNGAL VILLAGE SURVEY

UNNAT BHARAT ABHIYAN (UBA) BASELINE HOUSEHOLD SURVEY

**S.KARTHICK
 A.CHANDRU
 K.SALMAN KALEEM**

LIBRARY

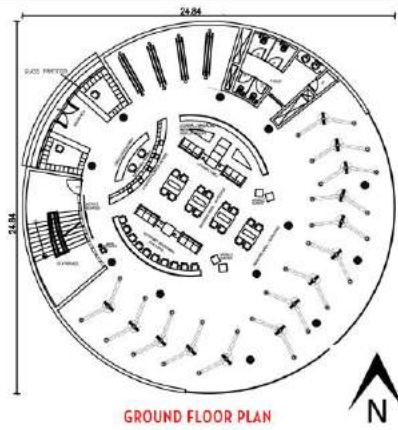

SCHOOL

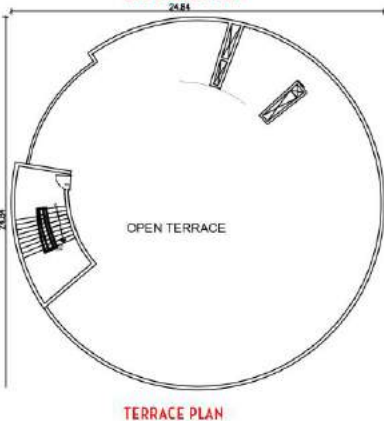
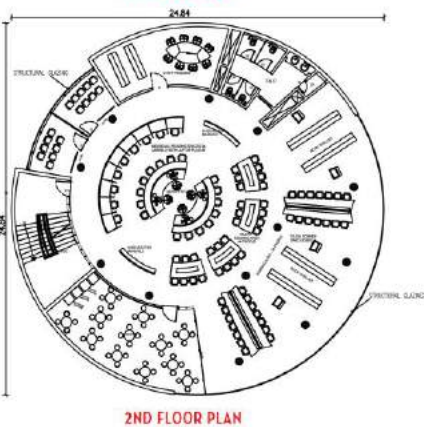
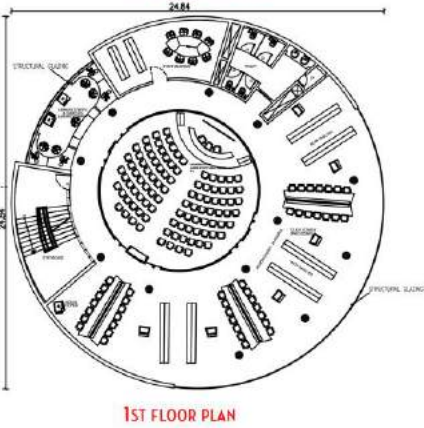
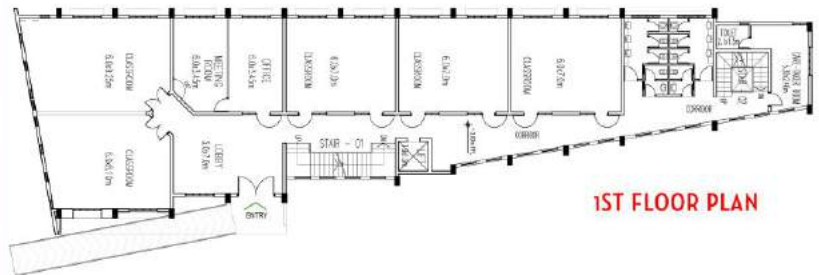

ELEVATION

There is a steady rise observed in the number of enrollments in school each year...With ever increasing literacy rate, there is also an increasing longing for a library and school with higher classes (the existing school has facilities only for primary education). Also, it would provide the students with a sense of purpose and meaning in pursuing studies if they have a men's to continue higher studies.



ARUNGAL VILLAGE SURVEY-PROPOSAL

UNNAT BHARAT ABHIYAN (UBA) BASELINE HOUSEHOLD SURVEY

S.KARTHICK
A.CHANDRU
K.SALMAN KALEEM

TEAM 5: STREET LIGHT PROPOSAL - DHEEBAN RAJ A & INDHUSRI S

STREET LIGHT PROPOSAL FOR ARUNGAL VILLAGE

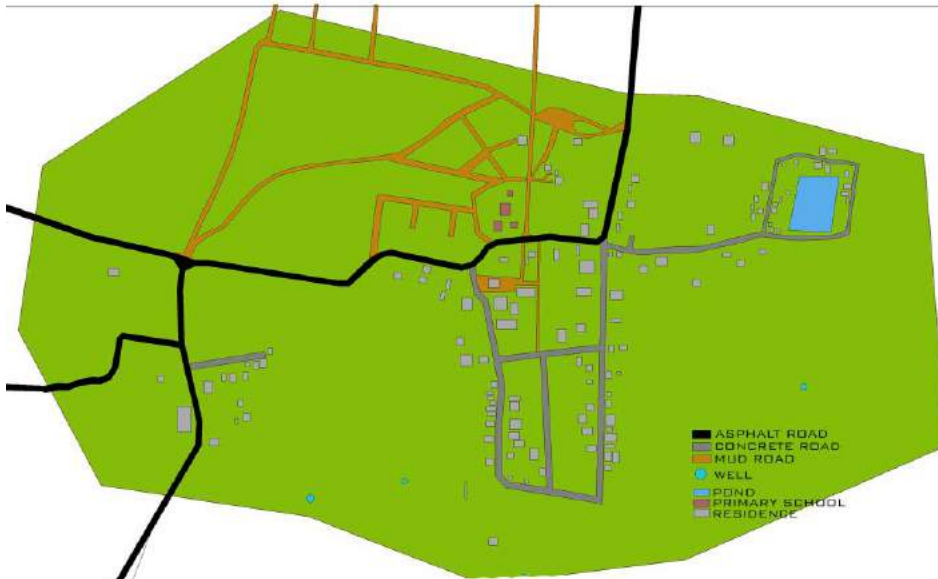

LAND USE MAP

STREET LIGHTS ARE PLACED AT THE HEIGHT OF 7 TO 9 M AND THEY PLACED THE DISTANCE OF 30 MTS EACH .

AFTER THE SURVEY AND ANALYSIS THERE IS A LACK OF PROPER ROADS AND STREET LIGHTS WHICH MAY LEAD TO ACCIDENTS AND OTHER THREATS.

AFTER THE DATA COLLECTION AND STUDY ABOUT THE STREET LIGHTS! WE OPT LED OR FLUORESCENT TUBULAR LAMPS FOR ENERGY EFFICIENT OPTIONS FOR STREET LAMPS !



DAYLIGHT VIEW OF THE STREET LIGHT PLACED IN THE SITE

LACK OF PROPER STREET LIGHT



EXISTING STREET LIGHT

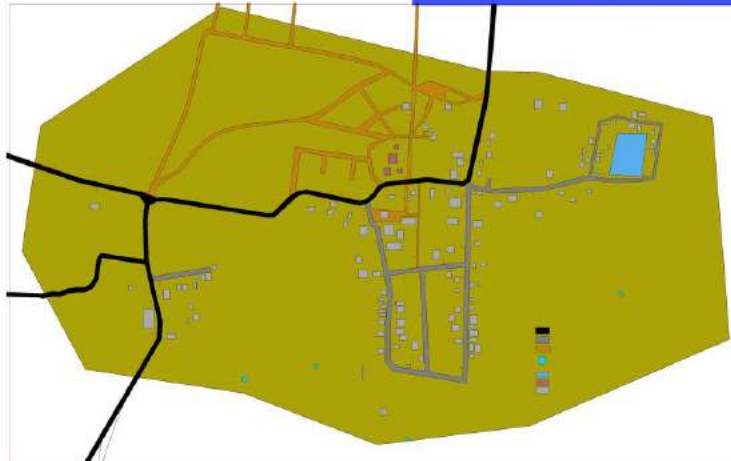

PROPOSED STREET LIGHT



DHEEBANRAJ.A . INDHUSRI.S

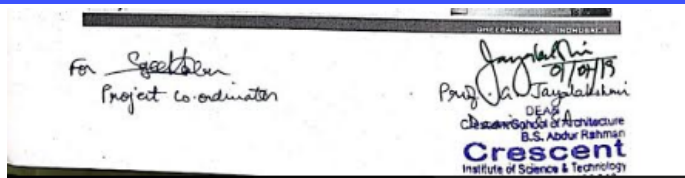

Report

Date of Visit: 10 to 16th June-2019

Educational trip-Dubai

A city known for superlatives, you'll find eye-popping architecture on every corner. From the world's tallest tower and most luxurious hotel to space-age structures that defy gravity.

Preamble :

Dubai is largely admired by what it has achieved in the last 30 years. It became one of the richest cities in the world and generated some of the most daring and groundbreaking engineering and architectural achievements to date. It is home to the world's tallest building, largest shopping mall, largest indoor ski slope. It is expanding its territory towards the sea in the shape of several human-made islands, as well as investing in innovative transportation technologies and infrastructure. It will host the World Expo 2020, reinforcing its position in the international scene as an economic powerhouse in the middle east.

Student Details :

S.No	RRN No	Name
1	180101601003	AISHWARYA
2	180101601004	ASHWIN BALA
3	180101601005	BHUVANESWARI
4	180101601006	CHELSEA
5	180101601007	GREESHMA
6	180101601008	GURUBARAN
7	180101601009	HARIHARAN
8	180101601010	HARITHA
9	180101601011	HRITHIK
10	180101601012	KIRUBAKARAN
11	180101601014	MAMTHA
12	180101601016	TOWKEER KHAN
13	180101601017	RIYAZEN
14	180101601018	ROSHAN

CRESCENT SCHOOL OF ARCHITECTURE



15	180101601019	SAINAAGHA
16	180101601020	SHAIK SHAHUL HAMEED
17	180101601021	SRI PRADEESH
18	180101601022	SRIVATHSAN
19	180101601023	SUBHASHMI
20	180101601024	SUBHASREE
21	180101601026	VIJAY SIVA
22	180101601027	VISHNUVARTHAN
23	180101601028	VISWA
24	1801016010	SAEEMUDEEN
25	1801016010	SATHISH KUMAR
26	180101601029	ABDULLAH
27	180101601030	AVINASH
28	180101601031	BHUVANA
29	180101601032	DEEPIKA
30	180101601033	DHARANI
31	180101601034	EUNICE
32	180101601035	GHAZALA FATHIMA
33	180101601036	HAFEELA HUMAIDHA
34	180101601037	IZAZ AHAMED
35	180101601038	JOSEPH ASIR
36	180101601039	JUSTIN ALLAN
37	180101601041	MANI BALAJI
38	180101601043	MOHAMMED FAHIM
39	180101601044	MOHAMED WAHID ALI
40	180101601046	NATASHA
41	180101601047	NIHAAL
42	180101601048	ABHINAV
43	180101601049	SAI SRINIKETHAN
44	180101601050	SHAIK MOHAMED FAIZAL HUSSAIN
45	180101601051	SHREYA
46	180101601052	SIVARAMAKRISHNAN
47	180101601053	SUBHALAKSHMI
48	180101601054	SUDHARSHAN
49	180101601055	SUGUNESWARAN
50	180101601056	THIRUVENKATA SAHA
51	1801016010	MOHAMMED WASIM RAHMATHULLAH
52	1801016010	BHARATH
53	180101601042	MARZOOQ AHAMED

Sailent Features :

- The city's most fascinating modern structures.
- Construction techniques
- Visual connectivity between the places
- 'Burj Al Arab' is an inimitable hotel, it is peerless and the only 7-star hotel in the entire world
- innovation in the tourist spots
- Skyline

Photos :





Outcome:

- The students observed and learnt the contemporary architectural features of the City of Dubai and Abu Dhabi.
- Students interacted with the faculty and students of Herriot Watt University, Dubai and learnt to design a co – working space intended for the Dubai Expo 2020

Project Coordinator Sign

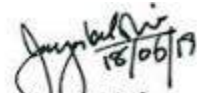
18/06/19
Prof. Jayalakshmi
Dean, Crescent School of Architecture

Dean
Crescent School of Architecture
& S. Abdur Rahman
Crescent
Institute of Science & Technology
GST Road, Vandalur, Chennai 600 048

•

Field Project report DakshinaChitra

11-AUG-18

CRESCENT SCHOOL OF ARCHITECTURE

B.ARCH

"**Architecture** is the learned game, correct and magnificent, of forms assembled in the light."

Field Project report

Site visit to DakshinaChitra

Preamble :

The students of the first semester B.Arch were taken to One-Day site visit to DakshinaChitra, Heritage Museum , on 11th August, 2018. The Museum is located overlooking the Bay of Bengal, at Muttukadu, twenty five kilometers south of Central Chennai.

The students were exposed to the traditional architecture of South India, vernacular materials. The students were asked to sketch the street views of the spaces, note the materials for building construction and techniques.

List of Student :

S.No	RRN NO	Student Name
1	180101601001	AADARSHKARTHIK. B
2	180101601002	AHAMED FAHIM HADHI
3	180101601003	AISHWARYA SREEKANTH
4	180101601004	ASHWIN BALA. V
5	180101601005	BHUVANESWARI. V
6	180101601006	CHELSEA VIJAY
7	180101601007	GREESHMA. M.S.
8	180101601008	GURUBARAN. M
9	180101601009	HARIHARAN. P
10	180101601010	HARITHA. G
11	180101601011	HRITHIK. D
12	180101601012	KIRUBAKARAN. A
13	180101601013	LAKSHMI RAMALINGAM GUNASEKARAN

14	180101601014	MAMTHA. K
15	180101601015	MUHAMMAD ZAAHID AKHTAR. A
16	180101601016	PATTAN TOWKEER KHAN
17	180101601017	RIYAZEN. S
18	180101601018	ROSHAN. S
19	180101601019	SAINAAGHA. R
20	180101601020	SHAIK SHAHUL HAMEED
21	180101601021	SRI PRADEESH. M
22	180101601022	SRIVATHSAN. R
23	180101601023	SUBHASHMI. R
24	180101601024	SUBHASREE. M.H
25	180101601025	SYED IMRAN
26	180101601026	VIJAY SIVA. S
27	180101601027	VISHNUVARTHAN. A.M
28	180101601028	VISWA
29	180101601058	DAFFRIN M
30	180101601060	SAEEMUDEEN.S
31	180101601061	SATHISH KUMAR M
32	180101601029	ABDULLAH. S
33	180101601030	AVINASH S
34	180101601031	BHUVANA
35	180101601032	DEEPIKA.K.P
36	180101601033	DHARANI
37	180101601034	EUNICE
38	180101601035	GHAZALA FATHIMA .G
39	180101601036	HAFEELA HUMAIDHA
40	180101601037	IZAZ AHAMED
41	180101601038	JOSEPH ASIR
42	180101601039	JUSTIN ALLAN S
43	180101601040	JYOTSANA S V
44	180101601041	MANI BALAJI
45	180101601042	MARZOOQ
46	180101601043	MOHAMED WAHID ALI.A. M
47	180101601044	MOHAMMED FAHIM.B
48	180101601045	MOHAMMED SHAFIQ.H
49	180101601046	NATASHA SURESH
50	180101601047	NIHAAL .E
51	180101601048	PASUPULA ABHINAV

52	180101601049	SAI SRI NIKETHAN.S
53	180101601050	SHAIK MOHAMED FAIZAL HUSSAIN
54	180101601051	SHREYA. R
55	180101601052	SIVARAMAKRISHNAN. S. K
56	180101601053	SUBALAKSHMI.S
57	180101601054	SUDHARSHAN.K
58	180101601055	SUGANESHWARAN S
59	180101601056	THIRUVENKATA SAHA.R
60	180101601057	MD WASIM RAHMATHULLAH.I
61	180101601058	BHARATH

Salient Features:

At DakshinaChitra instilled in practical experience and also a new perception on the subject. Further site visit provided a valuable opportunity, of learning from different Architectural perceptions for fellow students.



Outcome

- The students were able to sketch out-door views, perspectives of the Heritage Museum
- The students were exposed to vernacular materials and traditional architecture of South India.

Thirakavathi . S.M.
Project Co.ordinator Sign

Prof. G. Jayalakshmi

Dean/Crescent School of Architecture
DEAN
Crescent School of Architecture
B.S. Abdur Rahman
Crescent
Institute of Science & Technology
Vandalur, Chennai-600 040

Report

20.1.2019

Field Survey – Slum Clearance Board, Kannagi Nagar

Preamble :

In a self-governing nation, the objective of development is not to encourage one specific style of urban living, but to plan urban localities with the aim of offering individual citizens wider choices while simultaneously supplementing the abundant cultural styles. This field survey was conducted to find the the problem faced by the inner-city poor, living in unofficial settlements of the global south city (Chennai, India), when they undergo development-induced resettlement.

Student Details :

Sl. NO.	RRN	NAME
1	150101601017	MOHAMED RAIFAN. S
2	160101601001	ADNAN FARIS AFSAL
3	160101601007	FARHANA SHAIK
4	160101601009	FAYAZULAHAMED. S
5	160101601010	GOWTHAM. S
6	160101601011	HARI PRASANNA. P
7	160101601016	JERUSHA SORNAM. J
8	160101601018	KAMAL NAYANI. A.S
9	160101601019	KAMESH. P
10	160101601020	KARTHICK. M
11	160101601021	KARTHIKEYAN. J
12	160101601022	KRITHIKA. L
13	160101601023	MADHUMITHA. E
14	160101601032	MOHAMED RISWAN. K

15	160101601033	MOHAMED SUHAIL. S.M
16	160101601034	MOHAMED UMAR FAROOK. A
17	160101601035	MOHAMMED FARHATHULLAH. K
18	160101601080	SHIFA

Sailent Features :

- Livelihood issues and socio-economic characteristics of eligible PAPs are qualitatively brought out using a standard questionnaire.
- Relocated people at two resettlement sites, namely Kannagi Nagar and Chemmenchery (local areas in Chennai city) are interviewed as per the baseline survey questionnaire.
- The sample size of the interviews consisted of 10% of the affected slum population due to construction of the Chennai Port – Madhuravoyal Expressway. In total, it consists of 3635 households of which, each of the above three sites constituted one third of the interviewed population.

Photos :





Outcome:

Based on the data collected during the survey, recommendations were made regarding the financial issues faced by the governing authorities while making the resettlement and for maintaining the provided facilities at the resettlement site.

[Handwritten Signature]
Project Co.ordinator Sign

[Handwritten Signature]
27/07/19
Ar. G. Jayalakshmi,
Professor & Dean
Crescent School of Architecture.

DEAN
Crescent School of Architecture
B.S. Abdur Rahman
Crescent
Institute of Science & Technology
Vandapur, Chennai-600 047

EGMORE MUSEUM

CASE STUDY

BATCH- 2017-2022



LOCATION: EGMORE, CHENNAI

DATE : FEB 28, 2019

BATCH : 2017- 2022

SEMESTER : IV

**PURPOSE : LIVE CASE STUDY
FOR MUSEUM DESIGN**



- The Government Museum or Madras Museum is a museum of human history and culture located in the neighborhood of Egmore in Chennai, India. Started in 1851, it is the second oldest museum in India after the Indian Museum in Kolkata. It is particularly rich in archaeological and numismatic collections. It has the largest collection of Roman antiquities outside Europe. Among them, the colossal Museum Theatre is one of the most impressive. The National Art Gallery is also present in the museum premises. Built in Indo-Saracenic style, it houses rare works of artists like Raja Ravi Varma

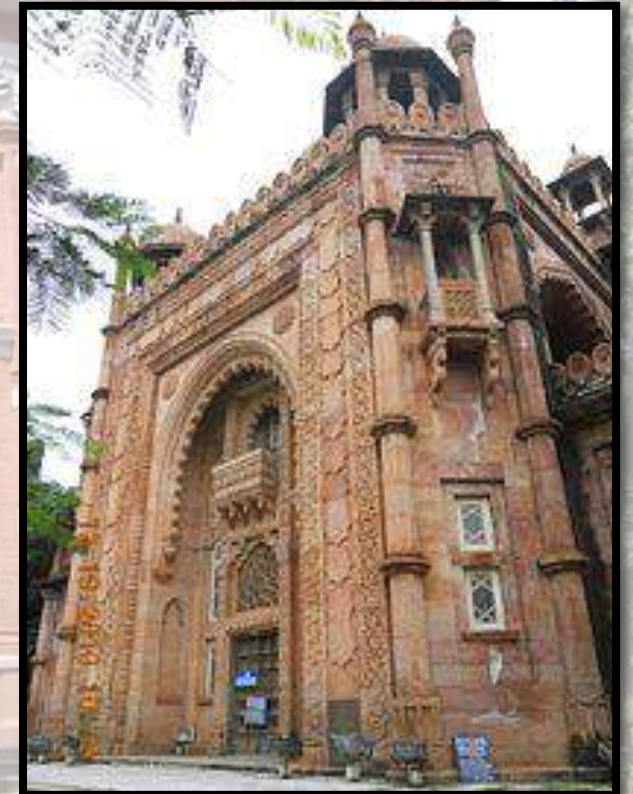

AIM:

- Aim of the case study included observing the building orientation and spatial complexes placed in center of Chennai
- Observation included the planning, materials, circulation, environmental factors
- As our design included the eyes of public, the main study was based on display factors, lighting, ventilation and security.
- The site study was based on the parking spaces, landscape and circulation







OUTCOME:

- The students understood the spatial organization of a public building and were able to relate to their design better in the Studio project.

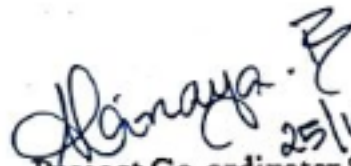
25/10/19
Project Co.ordinator Sign
(ARBINAYA)

02/01/19
Ar. G. Jayalakshmi,
Professor & Dean
Crescent School of Architecture.

Report

Educational trip- Case study visit

THOONDIL RESTURANT IN ECR,& TOSAI CLUB OMR

Preamble :

THOONDIL RESTURANT

Thoondil is located in ECR Chennai ,Thoondil is the Tamil word for a fishing rod. The restaurant has been designed keeping in mind the gorgeous flora and fauna that Tamil Nadu has to offer. There are bamboo fences all around with a granite Buddha statue in the middle. There are well spaced out individual huts with bamboo or teak furniture

TOSAI CLUB

Tosai Club, An exclusive restaurant situated in Thoraipakkam,OMR which delivers you with food, sports and music all at one place. A completely ship themed outdoor restaurant, built with actual shipping containers

Student Details :

S.No	RRN No	Name
1	180101601003	AISHWARYA
2	180101601004	ASHWIN BALA
3	180101601005	BHUVANESWARI
4	180101601006	CHELSEA
5	180101601007	GREESHMA
6	180101601008	GURUBARAN
7	180101601009	HARIHARAN
8	180101601010	HARITHA
9	180101601011	HRITHIK
10	180101601012	KIRUBAKARAN
11	180101601014	MAMTHA
12	180101601016	TOWKEER KHAN
13	180101601017	RIYAZEN
14	180101601018	ROSHAN
15	180101601019	SAINAAGHA

16	180101601020	SHAIK SHAHUL HAMEED
17	180101601021	SRI PRADEESH
18	180101601022	SRIVATHSAN
19	180101601023	SUBHASHMI
20	180101601024	SUBHASREE
21	180101601026	VIJAY SIVA
22	180101601027	VISHNUVARTHAN
23	180101601028	VISWA
24	1801016010	SAEEMUDEEN
25	1801016010	SATHISH KUMAR
26	180101601029	ABDULLAH
27	180101601030	AVINASH
28	180101601031	BHUVANA
29	180101601032	DEEPIKA
30	180101601033	DHARANI
31	180101601034	EUNICE
32	180101601035	GHAZALA FATHIMA
33	180101601036	HAFEELA HUMAIDHA
34	180101601037	IZAZ AHAMED
35	180101601038	JOSEPH ASIR
36	180101601039	JUSTIN ALLAN
37	180101601039	JYTOSONA
38	180101601041	MANI BALAJI
39	180101601043	MOHAMMED FAHIM
40	180101601044	MOHAMED WAHID ALI
41	180101601046	NATASHA
42	180101601047	NIHAAL
43	180101601048	ABHINAV
44	180101601049	SAI SRINIKETHAN
45	180101601050	SHAIK MOHAMED FAIZAL HUSSAIN
46	180101601051	SHREYA
47	180101601052	SIVARAMAKRISHNAN
48	180101601053	SUBHALAKSHMI
49	180101601054	SUDHARSHAN
50	180101601055	SUGUNESWARAN
51	180101601056	THIRUVENKATA SAHA
52	180101601058	MOHAMMED WASIM RAHMATHULLAH
53	180101601060	BHARATH
54	180101601042	MARZOOQ AHAMED





Outcome:

- Introduce the students to spatial planning with respect to existing site conditions.
- Building organization with respect to site features- built environment responsibility towards natural heating and cooling.
- Site planning and developments-relationship of open spaces and built spaces.
- To explore the relationship between interior and exterior spaces.
- Exterior layout-Designing with respect to the site context.
- Exploration of material and usage.



Project Coordinator Sign



Dean Signature
03/03/19

DEAN
Crescent School of Architecture
B.S. Abdur Rahman
Crescent
Institute of Science & Technology
Vandapur, Chennai-600 046

FIELD PROJECT REPORT

Place of visit: Residence, Veperi

Date of visit: 9.1.2019

PREAMBLE: A dwelling that provides and encourages an active lifestyle, and the ability



for residents to feel psychologically comfortable.

SALIENT FEATURES:

The residence is designed in such a way that the living space, bedrooms, toilet attains huge lighting inside through atrium and slits. The lavish and posh building made up of sandal and white stone in the exterior. The

architect has given equal importance to indoor and outdoor space. The outdoor place consists of party area and seating which is made up of natural materials like wood, stone etc. The vertical garden also brings an additional beauty to the exterior.

OUTCOME:

To understand the architectural form and space of residence. Aesthetic and psychological experience of form and space in terms of scale, color, light, texture, etc. Function and need: user requirements, anthropometrics, space standards, circulation.



STUDENT'S DETAILS:

S.NO	RRN	NAME
1	181431601001	AISHWARYA MOHANA SUNDAR
2	181431601002	ANCELIN.A
3	181431601003	BHAGESHRI. M
4	181431601005	DARVIN. C.P
5	181431601006	DIMPLE S
6	181431601007	FATHIMA ZAHRA A
7	181431601010	HEPSIBA.S
8	181431601011	IYSHWARRYA LAKSHMI R R
9	181431601012	JASMINE FATHIMA
10	181431601013	KAMALI.A
11	181431601014	MANI CHANDRAN. R. P
12	181431601015	MAARY JOSEPHINE NIVEETHA
13	181431601016	NAZIYAH FATHIMA S
14	181431601017	NIYAMATHUNNISA BEGAM.A
15	181431601018	RAGHA PRIYA S
16	181431601019	RAJADURAI S
17	181431601020	RIFATH AHAMED
18	181431601021	SAHANA S
19	181431601022	SAJID HUSSAIN M
20	181431601023	SAMEER AHMEED
21	181431601024	SAMYUKTHA R G
22	181431601025	SHAIK ABDUL RAHMAN S
23	181431601026	SHARAF KHAN M
24	181431601027	SHRUTHE SRI E
25	181431601028	SHRUTHI R.L
26	181431601030	SUDIPTI V.RAJAN
27	181431601031	SURYA C
28	181431601032	TASNEEM KOUSER S
29	181431601033	THEJASHWINI.J.L
30	181431601034	TIMPLE DHARSHINI. R
31	181431601035	USMAN GANI.N.M
32	181431601036	VIDHYA.M

 Ar.J.Milan Shamili
 CLASS COORDINATOR

 Prof. G. Jayalakshmi
 DEAN, CSA
 DEAN
 Crescent School of Architecture
 B.S. Abdur Rahman
Crescent
 Institute of Science & Technology
 Vandalur, Chennai-600 048



A REPORT

ON

INDUSTRIAL VISIT

**RAJIV GANDHI MEMORIAL TELECOM AND TRAINING CENTER,
BSNL MEENAMBAKKAM.**

BY

**DEPARTMENT OF COMPUTER SCIENCE AND ENGINEERING
B S ABDUR RAHMAN CRESCENT INSTITUTE OF SCIENCE AND
TECHNOLOGY
CHENNAI**

DATE :13/09/18.

Faculty Coordinator:

Mrs.R. Akila. (Asst.Prof (Sr.G)).

Accompanying Faculty:

Mrs.J. Brindha Merin (Asst.Prof).

Ms.Madhina Banu (Asst.Prof).

Ms.A Radhika (Asst.Prof).

PROFESSOR & HEAD
Department of Computer Science & Engg.
B.S. Abdur Rahman
Crescent
Institute of Science & Technology
Vandalur, Chennai-600 048.

Introduction

An industrial visit to RGM TTC, BSNL was scheduled for 3rd semester students of Computer Science and Engineering department with respect to their course “Computer Networks” to provide more depth knowledge on course and hands on experience from industry persons on 13/09/18. A total of 83 students attended the visit.

The students and faculty members were received by the PRO Ms.Thilakavathy Shankar, RGM TTC, BSNL, Meenambakkam, Chennai and divided the students into four groups of 28 students per batch and were given brief real time working and description of various equipment and components.

Session Details:

- Networking Fundamentals & Networking Devices
- Refreshment Break & Kit Distribution
- Real Time demonstrations on Live Networks, working of Routers and Switches.
- Networking Lab Visit

Summary of the Visit:

In Networking lab students were shown and demonstrated about various latest networking devices and components, they were also explained about fibre optic communication and various Single Segment IP Networks, Multiple Segment IP Networks and Static Routing, Dynamic Routing Protocols (RIP, OSPF and BGP), LAN switching, Transport Layer Protocols: UDP and TCP, NAT, DHCP, DNS, and SNMP. Students were given hands on experience on CISCO packet tracer with explanation for various protocols and IP versions.

Practical

- Hands-on on Cisco Packet Tracer by Students
- Creating a Local Network and Passing a packet via the whole network (simulation)
- Task given students to create a simulation for the DHCP connection type

Outcomes

- Students got hand-on experience of creating local area networks & routing the packet overnetwork using software packet tracer.
- Created simulation for DHCP connection.
- Students got the exposure of different Networking Device.

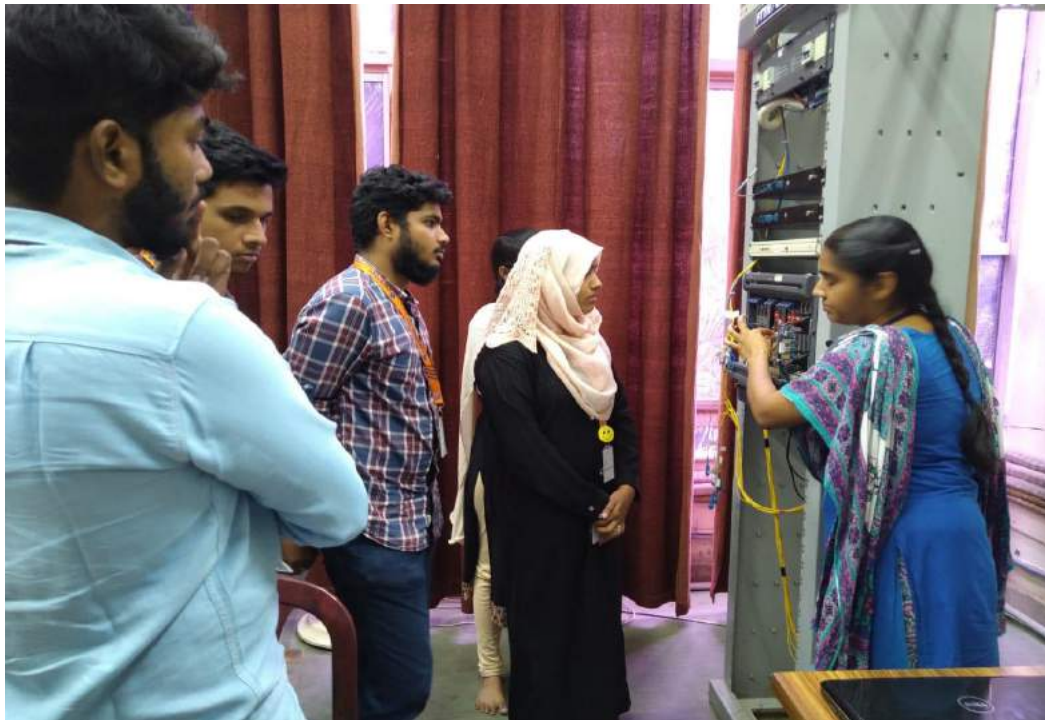



LIST OF STUDENTS
II YEAR CSE B NAME LIST

<u>Sl.No</u>	RRN	Name of Student
1	170071601050	ABDUL MAJITH.S.D
2	170071601051	ABDUL WADOOD M.S.
3	170071601052	ABINAYA A P
4	170071601054	AFRIN AYESHA S
5	170071601055	AFRIN.I
6	170071601056	AFSAL MOHAMED.M
7	170071601057	AHAMED ABDULLAH .M .I
8	170071601058	ANIRUDH S.V
9	170071601060	ANUSH.S
10	170071601061	ARCHANA M
11	170071601062	JANANI.R
12	170071601063	JEGAN RAGHUL M
13	170071601064	KHADER GHOUSE .A.M
14	170071601065	KHATHIJATH FARIHA S
15	170071601066	Kiruthiga R
16	170071601068	KODIDELA RAHIMAN
17	170071601069	KOTAPATI HARI CHAITHANYA
18	170071601071	MARIAM AAFREEN
19	170071601072	MD SHAARIF HISHAM.K
20	170071601073	MODEMREDDY VANDANA
21	170071601074	MOHAMED ABDUL GANI.M
22	170071601075	MOHAMED ASHIF I
23	170071601076	MOHAMED FAZIL.A
24	170071601077	MOHAMED NAJEEM FASIL A
25	170071601078	MOHAMED RAWLLA.A
26	170071601079	MOHAMED RISVAN H
27	170071601080	MOHAMMAD AZAM OZAIR
28	170071601081	MOHAMMAD MUJAHIDULISLAM
29	170071601082	MOHAMMED ABDUL AZEEM .A
30	170071601083	MOHAMMED ASHIQ G M
31	170071601084	MOHAMMED M IZZY
32	170071601085	MOHAMMED MUSTHAQ.S
33	170071601086	MOHAMMED NAVED
34	170071601087	MURUGAN P
35	170071601088	MUSHKHAN F
36	170071601089	NABEEL AHAMED. A
37	170071601091	NAKUL GNANASHEKAR. A

38	170071601093	NITHYA V V
39	170071601095	PATIMI NAGARJUN
40	170071601096	POOJITHA.K
41	170071601097	PRATHI KOTESWARA RAO
42	170071601111	HAJIRA SHIREEN .P
43	170071601113	HARINI.A
44	170071601116	HRITHIK K

II YEAR CSE C NAME LIST

S. NO	RRN	Name
1	170071601018	Kalaibharathi S
2	170071601100	Aarthi R
3	170071601103	Dinesh Kumar Gowd J
4	170071601105	Gadupudi Akhil
5	170071601106	Ganta Indra Sena Reddy
6	170071601107	Geriga Akanksha
7	170071601108	Girish Kumar B
8	170071601109	Gitith T
9	170071601114	Harish Kannan
10	170071601115	Harsha Vardhan M V S
11	170071601118	Pala Tharunesh
12	170071601119	Priyanka J
13	170071601120	Rajahsekharan S T
14	170071601121	Rampriyanth M B
15	170071601122	Roshan S
16	170071601123	Sabrin Fathima N
17	170071601124	Sai Girish Sowjerla
18	170071601125	Sai Koushik K
19	170071601126	Sankeerthana S
20	170071601127	Shaik Hassan Vali
21	170071601128	Shaik Javaheera
22	170071601129	Shaik Kuthubuddin
23	170071601130	Shaik Thouhid Salam
24	170071601132	Sowjanya R
25	170071601133	Sri Deepak Sakkaravarthi S S
26	170071601134	Sri Shailajaa Devi M J
27	170071601136	Suryam S
28	170071601137	Syed Avaiz Ahamed

29	170071601138	Syed Harish M
30	170071601139	Tejan S
31	170071601140	Tummala Divya
32	170071601141	Vanjipriya V
33	170071601142	Vishal Krishnan S H
34	170071601143	Vishal R K
35	170071601144	Vishal B
36	170071601145	Vishnu Teja D
37	170071601146	Yerra Gopi
38	170071601147	Zuvairiya Begum A
39	170071602001	Azhaan Mazhar

M. Qas

PROFESSOR & HEAD
Department of Computer Science & Engg.
S.S. Abdur Raheem
Crescent
Institute of Science & Technology
Vandalur, Chennai-600 045.

DEPARTMENT OF COMPUTER SCIENCE AND ENGINEERING

IBM Industry Visit , Chennai

B.Tech CSE – A section

IBM Specialization programme on AI, IOT & Big data analytics

Semester : 03



No. of students visited : 55

M. Sa
PROFESSOR & HEAD
Department of Computer Science & Engg.
B.S. Abdur Rahman
Crescent
Institute of Science & Technology
Vandalur, Chennai-500 048.

Session 1 : Ms.Nalini Kannan - IBM MaaS 360

Session 2 : Ms.Harini

Date of Visit : 30th October ,2018

Place of Visit : IBM India Pvt Ltd, Prince Infocity II,Chennai

Faculties accommodated:

1. Ms.Subhashini,AP/CSE – IBM CSE Joint program Coordinator
2. Ms.Radhika ,AP/CSE – Class Advisor – II year B.Tech CSE A

IBM support :

1. Ms.Sheetal Soni , Country manager
2. Ms.Naganandhini
3. Mr.Madhu



STUDENTS PARTICIPATED LIST

S.no	RRN	NAME
1.	170071601001	ABDUR RASHEED .N
2.	170071601002	ABINANDA VRISHNAA K
3.	170071601003	ABIRAMI E.E
4.	170071601004	ABU TALHA .I
5.	170071601005	ADITHYA RAJ R
6.	170071601006	AHAMED IRSHAD S.H.
7.	170071601007	ASHIK MOHAMMED B
8.	170071601008	ASHWINKUMAR S
9.	170071601009	BALAGANAPATHY .V.S
10.	170071601010	CIBHI. B
11.	170071601011	ELAVEINEE A
12.	170071601012	EMMANUEL K GREGORY
13.	170071601013	FATEMA-TUS-SUGRA Z LOKAT
14.	170071601014	HANIF FEROZ.S
15.	170071601015	HARIHARAN .A
16.	170071601016	HASHIM IRFAN ALI M
17.	170071601017	JAFFAR BAIG M
18.	170071601019	KISHAN RAJ G
19.	170071601021	MEKALA GIREESH NADH
20.	170071601022	MOHAMED ARSHAD S S
21.	170071601023	MOHAMED NASHEEN. K
22.	170071601024	MOHAMED SHAIK SULTAN M S
23.	170071601025	POOJA R
24.	170071601026	PRASANNA RAVI R
25.	170071601027	PRAVEEN KUMAR.S
26.	170071601028	PRAVEEN RAJ. J
27.	170071601029	PREETHI K
28.	170071601030	PURNIMA R S
29.	170071601031	RAEES AHMED P M
30.	170071601032	RAGHUL S
31.	170071601033	ROOBESH B
32.	170071601034	SAMUEL V
33.	170071601035	SAMYUKTHA P
34.	170071601036	SANTHOSH KUMAR T.
35.	170071601037	SATHYA RUPAN.T
36.	170071601039	SHAIK YASEEN BASHA



37.	170071601040	SHARON RENETA V
38.	170071601041	SHIVAMANI.A
39.	170071601042	SIDDHARTHA ROY
40.	170071601043	SURUTHIKASRI.M.K
41.	170071601044	SYED AZIMUDEEN G
42.	170071601046	SYED MULTHAZIM S J
43.	170071601047	VIGNESH P.
44.	170071601049	VISHAAL S
45.	170071601059	ANTONY PERCY RAJ. T
46.	170071601070	MANASHRI RAJA
47.	170071601090	NAHID FATIMA .S
48.	170071601092	NARGEES NILOFER
49.	170071601094	NIVETHA.G
50.	170071601102	ATCHAYA.A
51.	170071601104	DIWAN MYDEEN .S
52.	170071601112	HALITH RADUVAN.M
53.	170071601135	SUDHA.M
54.	170071601148	JAYASURYA.J
55.	170071601149	MOHAMMED ASHRAF .F

M.Sa
PROFESSOR & HEAD
Department of Computer Science & IT
B.S. Abdur Rahman
Crescent
Institute of Science & Technology
Vandalur, Chennai-600 048.

Students feedback about the session as follows:

Session 1: Ms.Nalini Kannan - IBM MaaS 360

" We got the opportunity to learn about IBM product ,MaaS360. The product was 14 years old but the functions and services was clearly explained by the speaker.In this MaaS360 product presentation,we came to know how the IBM produce their products and what different functions they do.The whole session was very useful and interesting."

" This session is more technical oriented..it was all about Cyber Security,we feel it would have been great if it was about the domain which we opted for..bcz we don't have any idea about those topics..though she gave her best to cover a overview of the topic..but more technical stuff..We were able to understand something what she is tried to convey,but it was just like user manual,collection of facts."

Session 2: Ms.Harini

"She clearly explained about the IBM process and functions on software and hardware. We admired on her communication skill,it was excellent and it was very interactive.We came to know about IBM and their field of work in deep.She was not tired of answering the questions asked by us. She proved how IBM is the best around the world and that made everyone to dream about a job in IBM"

Overall feedback and suggestions:

"Sessions were very informative and very effective. There was no dull or overdose moments. The IBM campus is well maintained and pucca security arrangements were done."

"The industry visit gave us idea of how the company environment actually is and helped us to understand how the company environment is different from the college environment. It also gave us various insights on how one should prepare themselves before joining any company. It would have been more good if we were able to see how people actually work and what they work on eventhough we understand due to security reasons it can't be done"

Staff In-charge
(SUBHASHINI.S)

HOD/CSE
PROFESSOR & HEAD
Department of Computer Science & Engg
B.S. Abdur Rahman
Crescent
Institute of Science & Technology
Vandalur, Chennai-500 045

FIELD VISIT

Medicinal Garden, Directorate of Horticulture & Plantation Crops, Tamil Nadu.

Year: 2018-19 Batch: B.Pharm. (2017-2021) & (2018-2022)

Date: 25-03-2019

No: of Students: I.B.Pharm: 49

No: of Faculty members: 4

II.B.Pharm: 45

Organized by

Crescent School of Pharmacy

BSACIST, Vandalur, Chennai-48

Education is learning what you didn't even know you didn't know.



B.S. Abdur Rahman

Crescent

Institute of Science & Technology

Deemed to be University u/s 3 of the UGC Act, 1956

GST Road, Vandalur, Chennai 600 048

REPORT ON FIELD VISIT

Medicinal Garden, Directorate of Horticulture & Plantation Crops, Tamil Nadu.

I. Preamble:

“We now accept the fact that learning is a lifelong process of keeping abreast of change. And the most pressing task is to teach people how to learn.”

As our lifestyle is now getting techno-savvy, we are moving away from nature. While we cannot escape from nature because we are part of nature. As herbs are natural products they are free from side effects, they are comparatively safe, eco-friendly and locally available. Traditionally there are lot of herbs used for the ailments related to different seasons. There is a need to promote them to save the human lives.

These herbal products are today are the symbol of safety in contrast to the synthetic drugs, that are regarded as unsafe to human being and environment. Although herbs had been priced for their medicinal, flavouring and aromatic qualities for centuries, the synthetic products of the modern age surpassed their importance, for a while. However, the blind dependence on synthetics is over and people are returning to the naturals with hope of safety and security. It's time to promote them globally.

II. About the Visit:

A field visit for the I & II B.Pharm. Students were organized at Medicinal Garden, Directorate of Horticulture & Plantation Crops, Chennai. The visit was organized on Thursday, March 25, 2019.

The participants in the visit were...

49 students from B.Pharm. Ist Year and 45 students of B.Pharm. IInd year

04 faculty members – Dr.S.M.Shaheedha, Dr.Y.Ismail, Dr.Haja Nazeer Ahamed and Mr. Mohammad Habeeb

Coordinated by – Dr.S.M.Shaheedha

The visit to the medicinal garden was made mainly to provide students with an opportunity to learn about how to identify plants and to take plant samples for specimen making and to know about the uses of them. Upon arrival at the medicinal garden, all of us were received with a warm welcome from the staffs of the horticulture department. The Director, Mr. Elango focuses his research on medicinal plants, Systematics (Taxonomy) and Ecology. This visit began at the medicinal museum where Mr. Elango explained to us about the different medicinal plants and their uses. Shortly after this briefing, we were taken to a small garden outside the museum and began to identify the family of each plant based on their characteristics. We were then taken to the greenhouse to continue with the learning. We were also encouraged to take samples of a few plants along the way to be made into specimens in a workshop session after the visit.

The following are the list of students participated in the industrial visit:

Co-ordinator: S.M. Elango
25/3/19

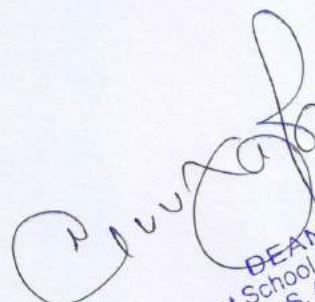
25.03.19
BEAN
Crescent School of Pharmacy
B.S. Abdur Rahman
Crescent
Institute of Science & Technology
Vandalur, Chennai-600 048.



B.S. Abdur Rahman

Crescent
Institute of Science & Technology

Deemed to be University u/s of the UGC Act, 1956
GST Road, Vandalur, Chennai 600 046

Crescent School of Pharmacy

List of I B. Pharm. (2018-19) Students participated in the Field Visit on 25-03-2019

S.No	RRN	Name of the Student	Signature
1	188021601001	AALIYAH JABEEN K H	ABSENT
2	188021601002	ABDUL RAHMAN BADUSHA A	A. Abdulrahman
3	188021601003	AFREEN BEGUM R	Afreen Begum
4	188021601004	AFFRIN TAJ H	ABSENT
5	188021601005	AKEELA FARSANA B	Akeela farsana
6	188021601006	ARAVINDH HEARAM R G	ABSENT
7	188021601007	ASMATH BANU A	ABSENT
8	188021601008	BASITHREHMAN S	S. Basithrehman
9	188021601009	BASLUR RAHMAN B	B. Baslur Rahman
10	188021601010	BHARATHI S	B. Bharathi
11	188021601011	FRANKLIN SYLVESTER C	C. Franklin Sylvester
12	188021601012	GAYATHRI P	P. Gayathri
13	188021601013	HAFSA TANVEER	Hafsa Tanveer
14	188021601014	HEM SHARATH V	V. Hem Sharath
15	188021601015	HEMALATHA S	S. Hemalatha
16	188021601016	JABEEN UNISSA M	M. Jabeen Unissa
17	188021601017	JANANI S P	J. Janani
18	188021601018	JAWITH SAHUL A	ABSENT
19	188021601019	JAYAKUMAR S	S. Jayakumar
20	188021601020	JAYALAKSHMI J	J. Jayalakshmi
21	188021601021	JESSICA S	J. Jessica
22	188021601022	KAMALEESWARI C V	C. Kamaleeswari
23	188021601023	KANAKAMBIGAI M	M. Kanakambigai
24	188021601024	KANNAN S	ABSENT
25	188021601025	KAVIYASHRI V T	V. Kaviyashri
26	188021601026	KOUSHIKA M	M. Koushika
27	188021601027	MALARVIZHI J	J. Malarvizhi
28	188021601028	MOHAMED ASHIF S	M. Mohamed Ashif
29	188021601029	MOHAMED ASIK A	A. Mohamed Asik
30	188021601030	JASMINE BEGAM J	J. Jasmine Begam
31	188021601031	MOHAMED SAJITH Z	Z. Mohamed Sajith

32	188021601032	MOHAMED SALMAN K	K. Mohd. Salim.
33	188021601033	MOHAMED YASEER S	S. Mohd. Yaseer
34	188021601034	MOHAMMED IDREES H	ABSENT
35	188021601035	MOHAMMED MEERAN MASTHAN K	ABSENT
36	188021601036	MOOSA FARIDH R	M. Faridh R.
37	188021601037	MUHAMMAD HAASHIR	ABSENT
38	188021601038	NITHYA E	Nithya E.
39	188021601039	PRITHIVIRAJAN S	Prithivirajan S.
40	188021601040	RAJAN B	Rajan B.
41	188021601041	RAMYA D	Ramya D.
42	188021601042	REVATHY U	Revathy U.
43	188021601043	RIZWANA PARVEEN N	Rizwana Parveen N.
44	188021601044	ROHITH KRISHNAN R	Rohith Krishnan R.
45	188021601045	RUBINA AAFRIN S	Rubina Aafirin S.
46	188021601046	SALEEMA M	M. Saleema
47	188021601047	SAMEER KHAN S	S. Sameer Khan
48	188021601048	SHANTHI D	S. Shanthi D.
49	188021601049	SNEHA K	Sneha K.
50	188021601050	SUGIRDHA PRINCESS J	Sugirdha Princess J.
51	188021601051	SURYA S	Surya S.
52	188021601052	SUTHAKAR A	ABSENT
53	188021601053	SWATHI R	R. Swathi
54	188021601054	SWETHA S	S. Swetha
55	188021601055	THEVIKKA K P	P. Thevika
56	188021601056	UDHAYA KUMAR S	ABSENT
57	188021601057	VINODHINI M	M. Vinodhini
58	188021601058	YASMEEN M	M. Yasmeen
59	188021601059	YEHYA AMMAR A	A. Yehya Ammar
60	188021601060	ZAINAB NASREEN G	G. Zainab Nasreen

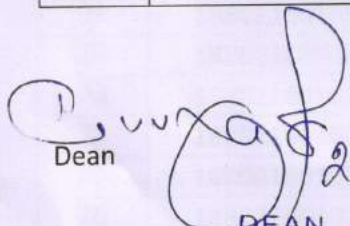
Dean

 25.03.19

DEAN
 Crescent School of Pharmacy
 B.S. Abdur Rahmani
Crescent
 Institute of Science & Technology
 Vandalur, Chennai-600 043



CRESCENT SCHOOL OF PHARMACY

List of IB. Pharm. (2018-19) Students participated in the Field Visit on 25-03-2019

Sl. No.	RRN	Name of the Student	Signature
1	178021601001	AANANTHA KUMARAN R.	R. Anantha
2	178021601002	ABDUL RASHEED EBRAHIM S.J.	Abdul Rasheed
3	178021601003	AKTHAR ALI R.	ABSENT
4	178021601004	ANWAR AHAMED R.	A.A.R.
5	178021601005	ARAVINDHAN V.	V.A.V.
6	178021601006	ARUN P.	Arun
7	178021601007	DHAMEEM RAMEEZA A.	Dhameem
8	178021601008	DHARUN P.R.	Dharun
9	178021601009	FAYAS AHAMED Z.	ABSENT
10	178021601010	FIRDOSE A.	Firdose
11	178021601011	HARIHARAN E.	E. Hariharan
12	178021601012	INZAMAM UL HAQ S.	ABSENT
13	178021601013	JENIFER JANSIRANI L.	J. Jennifer
14	178021601014	KALAI VANI V.	K. Vani
15	178021601015	KEERTHANA D.	Keerthana
16	178021601016	KIRTHIKA G.	K. Kirthika
17	178021601017	LAKSHMANAN M.	M. Lakshmanan
18	178021601018	MAHALAKSHMI C.	C. Mahalakshmi
19	178021601019	MARUVAN J.	J. Maruvan
20	178021601020	MINU GAYATHRI R.	ABSENT
21	178021601021	MOHAMED ABDULLAH M.	ABSENT
22	178021601022	MOHAMED AJMAL A.	ABSENT
23	178021601023	MOHAMED AKRAM V.	M. Akram
24	178021601024	MOHAMED ALI I.	Mohamed Ali
25	178021601025	MOHAMED ANSAR A.S.	Mohamed Ansar
26	178021601026	MOHAMED ASRI M.	ABSENT
27	178021601027	MOHAMED RIFAYEE U.	U. Rifayee
28	178021601028	MOHAMED YAKEEN F.	ABSENT
29	178021601029	MOHAMMED ARIF M.	M. Md Arif
30	178021601030	MOHAMED IBRAHIM M.	M. Ibrahim



31	178021601031	MOHAMED IBRAHIM A.	A. Ibrahim
32	178021601032	MOHAMMED MUZAMMIL M.S.	ABSENT
33	178021601033	MUFASAL MUFITH A.N.	Muf
34	178021601034	MUSHADIQ A.	ABSENT
35	178021601035	NAVEEN KUMAR K.	Naveen
36	178021601036	NIHARA PARVEEN M.	Nihara.M.
37	178021601037	RAJESHWARI A.	Rajeshwari.A.
38	178021601038	RANJITH KUMAR S.	S. Ranjith
39	178021601039	RESHMA MALINI S.	S. Reshma malini
40	178021601040	RESHMA S.	Reshma.S.
41	178021601041	ROHITH J.	ABSENT
42	178021601042	SANGEETHA K.	S. Sangeetha
43	178021601043	SARANYA K.	K. Saranya
44	178021601044	SELVA KUMAR A.	ABSENT
45	178021601045	SEYED IBRAHIM SOOFI M.	ABSENT
46	178021601046	SHALINI M.	Shalini.M.
47	178021601047	SHANKAR GANESH K.	ABSENT
48	178021601048	SHOAIB ASLAM S.	ABSENT
49	178021601049	SIVAJOTHI V.	V. Sivajothi
50	178021601050	SNEHA H.	H. Sneha
51	178021601051	SRI DHARSHINI V.	V. Sri Dharshini.
52	178021601052	SUBASH M.	M. Subash
53	178021601053	SUFIYAN M.F.	S. M.F.
54	178021601054	SWETHA V.	V. Swetha
55	178021601055	SYED ALI FATHIMA H.	H. Syed Ali Fathima
56	178021601056	SYED RISWAN K.	K. Syed Riswan
57	178021601057	TAMIL AZHAGAN V.	V. Tamil Azhagan
58	178021601058	TASNEEM A.K.	A.K. Tasneem
59	178021601059	VARSHIA BANU A.	A. Varshia Banu
60	178021601060	VINOTH P.	P. Vinoth

 Dean
 DEAN 25/03/19
 Crescent School of Pharmacy
 B.S. Abdur Rahman
Crescent
 Institute of Science & Technology
 Vandalur, Chennai-600 048.



एनएलसी इंडिया लिमिटेड-NLC India Limited
(Navratna- Government of India Enterprise)
CIN L93090TN1956GO1003507 Website :www.nlcindia.com



Public Relations Department
Block-2, Neyveli-607 801, Cuddalore District, Tamil Nadu
e-mail : pr.dept@nlcinda.com, pro.nlc57@gmail.com Tele Fax : 04142- 252257

Lr.No.100 Visit/PRD/2019

Date: 12/03/2019

To
Dr.Y.Mohamed Shuaib,M.E.,Ph.D.,
Head of Dept./EEE,
Crescent Institute of Science & Technology,
Chennai-44.

B.E EEE II & IIIrd Year

Sub: PRD – Visit to Industrial Units – Confirmation – Reg.

Ref: Lr. received dt. 23.01.2019,

We are in receipt of your letter dated: 23.01.2019. The group of visitors from your Institution are permitted to visit **Mine-I & Tps-I Expn.only.** on 22/03/2019. Please advise them to contact the Public Relations Dept., (Near Nehru Square), Block-2, Neyveli Township – 607 801 at 9.30 A.M.

The visitors/students are requested to bring their Identity Card along with TWO COPIES OF NAME LIST during their visit to Neyveli. In case of foreign students please attach passport size photo's 2 No's and two copy of passport and registration certificate /Residential Permit [RC/RP],From 'A' [Rule 6]issued by BUREAU OF IMMIGRATION M.H.A Govt. of India,one week before. Cell Phones with Cameras / Still Cameras / Video Cameras are strictly prohibited inside the Industrial Units.

We request you to arrange your own conveyance/accommodation during the visit.

Thanking you,

Yours faithfully,
for NLC India Ltd,

General Manager/PR
General Manager / PR
NLC Limited
Neyveli - 607 801

Handwritten note: *Handwritten note: 100 PR for n. v.*

Handwritten note: *Handwritten note: 12/3/19*

परीकृत कार्यालय : प्रथम इल नं.३, मेयर सत्यमूर्ति रोड, एन.एल.सी., एमपी कॉम्प्लेक्स, भारतीय खाद्य निगम, चेन्नई-६०० ०३१.
REGD.OFFICE : 1st Floor, No.3, Mayor Sathyamurthy Road, FSD, Egnore Complex of Food Corporation of India, Chetpat, Chennai - 600 031.
CORPORATE OFFICE: BLOCK-1, NEYVELI - 607 801, CUDDALORE DISTRICT, TAMILNADU.
निगमित कार्यालय: ब्लॉक-१ नेयवेली - ६०७८०१, कडलूरु जिला, तमिलनाडु.



B.S. Abdur Rahman

Crescent

Institute of Science & Technology

Deemed to be University u/s 3 of the UGC Act, 1956

GST Road, Vandalur, Chennai 600 048

A STUDY ABOUT POWER GENERATION

An Industrial Visit to NLC and Thermal Power Plant (Neyveli)

Submitted By:

THE STUDENTS OF EEE 2nd Year

DEPARTMENT OF ELECTRICAL AND ELECTRONICS ENGINEERING

**B S ABDUR RAHMAN CRESCENT INSTITUTE OF SCIENCE AND TECHNOLOGY,
CHENNAI**



Neyveli Lignite Corporation

ACKNOWLEDGEMENT

We are thankful to Dr Y. Mohamed Shuaib, Assoc. Professor & HoD/EEE

Mr. A. Paramasivam, AP/EEE

Mr. F. Valiyullah Khan, AP/EEE

Mr. M. Syed Asanar, Senior Technician

This trip was of a great experience which gave a real exposure to the industry. It was highly beneficial for all students as it explained the theoretical and practical concepts both.

We are also thankful to all the instructors at NLC India Limited who provided the detailed explanations of plant operation and helped us preparing short notes during the trip. They also led us to background and requirements of substation

29 students of II year EEE and of B. S. Abdur Rahman Crescent Institute of Science and Technology visited NLC India Limited on 22-03-2019.

PURPOSE OF VISIT

Our main purpose for this visit is to become familiar with industrial environment and to gain practical knowledge about electrical power generation, transmission etc.

GENERAL INFORMATION

NLC India Limited (formerly **Neyveli Lignite Corporation Limited**) (**NLC**) is a 'Navratna' government of India company in the fossil fuel mining sector in India and thermal power generation. It annually produces about 30 million tonne lignite from opencast mines at Neyveli in the state of Tamil Nadu in southern India and at Barsingsar in Bikaner district of Rajasthan state. The lignite is used at pithead thermal power stations of 3240 MW installed capacity to produce electricity. Its joint venture has a 1000 MW thermal power station using coal. Lately it has diversified into renewable energy production and installed 141 MW solar power plant to produce electricity from photovoltaic (PV) cells and 51 MW electricity from windmills.

As Our Department has arranged us Industrial visit for third year students of EEE DEPARTMENT, on 22.03.2019(Friday) sharply at 6.00A.M all the second year students (29 members) along with 2 Assistant Professors Mr. A. Paramasivam (AP/EEE), Mr. F. Valliyullah Khan (AP/EEE). Boarding on the bus and reached “NEYVELI LIGNITE CORPORATION-CUDDALORE DISTRICT” at 11.00A.M. After the visit of Thermal power plant we started the bus at 5.00P.M and we reached the college at 9.00P.M.

Industrial Visit was organized by Electrical and Electronics department. Under the guidance of our (HOD/ Associate Professor of EEE dept) Dr. Y. Mohamed Shuaib and Mr. A. Paramasivam (Assistant Professor of EEE department). There we have learnt about the developed products of the plant such as electricity generation distribution.

MINING PROJECTS

NLC has four opencast lignite mines, namely, Mine I, Mine II, Mine IA and Barsingsar Mine. The lignite mined out is used as fuel to the linked pithead power stations. Also raw lignite is being sold to small scale industries to use it as fuel in their production activities.

Mines	Capacity (in MTPA)
Mine I	10.5
Mine I A	3.0
Mine II	15.0

The lignite seam was first exposed in August 1961 and regular mining of lignite commenced in May 1962. German excavation technology in open cast mining, using Bucket Wheel Excavators, Conveyors and Spreaders were used for the first time in the country in Neyveli Mine-I. The capacity of this mine was 6.5 MT which met the fuel requirement of TS-I. The capacity was increased to 10.5MT of lignite per annum from March 2003 under Mine-I expansion scheme and at present meets the fuel requirement for generating power from TPS-I and TPS-I Expansion.

We also got to know about the life span of each lignite mine patch, process of mining what the do to the land after mining, the bi-products, lignite transportation, feeding lignite to boilers, steam generation, steam cycle, cooling towers, ash management system, etc.



 Mine- I Salient features							
Particulars	Unit	Mine-1	Particulars	Unit	2016-17	2017-18	Since Inception
Mining Lease Area	Sq. Km.	36.354	Overburden Excavated	MM ³	53.41	43.75	1983.61
Capacity / Annam	MT	10.5	Lignite Mined	MT	9.40	8.15	351.59
Lignite Reserve	MT	466.32	Area Mined out	Hectares	62.99	78	2276.33
OB Thickness	Mts.	45 to 110	Area Reclaimed	Hectares	45.5	61.35	834.9
Lignite Thickness	Mts.	8 to 26	Area Afforested	Hectares	38.22	46.17	792.1
Average Stripping Ratio	Tons: M ³	1 : 5.5	Tree planted	Numbers	31485	21070	8,21,695
Mining Started on	Date	20.05.1957	Cost of Production	Rs/Ton	2024	2143	-
Lignite First Exposed	Date	24.08.1961	Profit	Crore Rs	320.97	369.46	-
Balance Lignite Reserve (as on)	MT	114.727	Linked Power Stations	TPS-1 (600 MW), TPS-1 Expn.(2 X 210 MW) & NNTTP (2X500MW) Under Construction			

THERMAL POWER PLANT – I

In the afternoon, after lunch, we visited the thermal power station-I to learn about its working. We were brought to the aerial view where the in-charge faculty thoroughly explained each process happening.

We also witnessed the inside of the generation unit building and we got an idea about the safety and interruption-less operation of the

alternator (generator). We got to know about the alternator rating (11KV), the ventilation system, etc. We also had a glance at the control unit of the entire power plant from a distance which operates on different software one of which is SCADA.

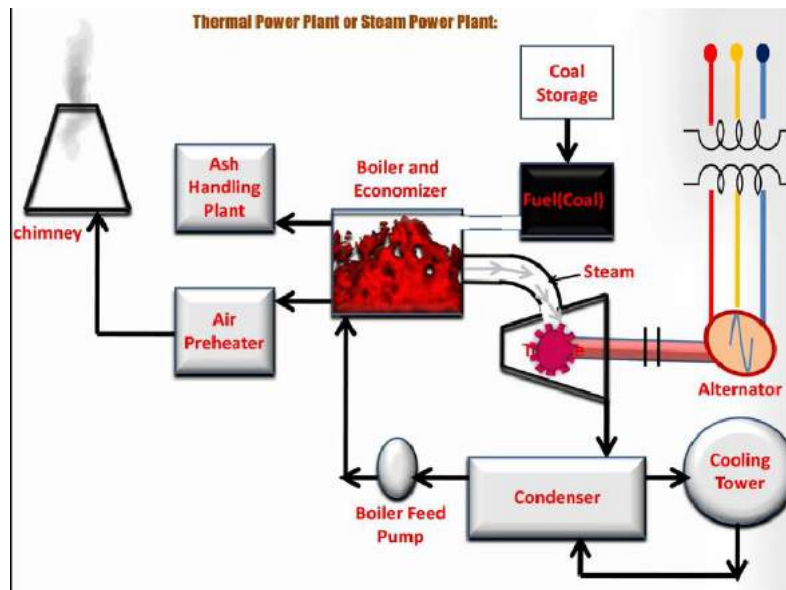

The above picture depicts the block diagram of the thermal power plant. It was a refreshing experience to see the things we learn about in action and we appreciate the department and faculties' in-charge for arranging this industrial visit for us. We heartily thank you all and we look forward to more such industrial visits in the upcoming semesters.

CONCLUSION

From this visit, we got the information and practical knowledge about Power Generation and Transmission. 29 students were benefited from this visit as we got chance to discuss with assistant engineers working at plant.



B. S. ABDUR RAHMAN CRESCENT INSTITUTE OF SCIENCE AND TECHNOLOGY

DEPARTMENT OF ELECTRICAL AND ELECTRONICS ENGINEERING

II YEAR EEE- 2017-21

INDUSTRIAL VISIT ATTENDANCE

Date: 22/03/2019

S.No.	RRN No.	Name of the Student	Signature
1	170041601001	ADITH SENTHIL KUMAR	
2	170041601002	ANWAR SADATH. S	ABSENT
3	170041601003	ABARNA.R	
4	170041601004	ARSHATH BILAL.R	
5	170041601006	N.M.GUGHAN	
6	170041601007	JUNAIDMOHAMMED.M	
7	170041601008	KANNAN.R	
8	170041601009	KARTHIGA.K.R	
9	170041601010	KEERTHI RANLR	
10	170041601011	KRITHIKA.H	
11	170041601012	MAHA HANIFA RABI	
12	170041601013	M.MOHAMED ABUBACKAR SHIDDIK	
13	170041601014	MOHAMED ARSHAD.J	
14	170041601015	MOHAMED HANEEF F	
15	170041601017	MOHAMED RIAZ.N	
16	170041601018	MOHAMMED SALLA	
17	170041601019	MOHIT JAISINGH.M	
18	170041601021	NIHAL	ABSENT
19	170041601022	SHAKSHAVALLI.P.S	
20	170041601023	RANGANATHAN.S	
21	170041601024	ROHITH.H	
22	170041601025	SAJITH FARAS.S	
23	170041601026	SAKTHIKUMAR.G	
24	170041601028	SEYED MOHAMED SALHU.M.N	
25	170041601029	SHAKIR HASSAN DAR	
26	170041601030	SEWETHA.K	
27	170041601031	STEFFI CARVALHO	
28	170041601032	SYED MOHAMMED R. MUDDIN.A	
29	170041601033	TAMBOLI ILIYAS YAKUB	
30	170041601035	FADHIAL.ULLAH INAYADULLAH	
31	170041601036	S. H. ASEELAN.M	

9/19/2018

B.S. ABDUR RAHMAN UNIVERSITY Mail - Re: Fw: Requisition for Permission to visit your Industry -Reg.



HOD EEE <hodeee@crescent.education>

Re: Fw: Requisition for Permission to visit your Industry -Reg.

sakthitransformers 2017 <sakthitransformers2017@gmail.com>
To: hodeee@crescent.education

18 September 2018 at 18:24

Dear Sir / Madam
OK. We accept your request below the date. 25.09.2018
Thanks & Regards,



T.K.RAMAJAYAM,
(PARTNER)

"SAKTHI TRANSFORMERS"



Phone : 044-24780654,+91- 9840163572,
Email : sakthitransformers@yahoo.com,
Chennai -600-069.

On Tue, 18 Sep 2018 at 17:26, "SAKTHI TRANSFORMERS" <sakthitransformers@yahoo.com> wrote:

Sent from Yahoo Mail for iPhone

Begin forwarded message:

On Tuesday, September 18, 2018, 3:30 PM, HOD EEE <hodeee@crescent.education> wrote:

Dear Sir/Madam,

Greetings from B.S. Abdur Rahman Crescent Institute of Science & Technology.

Sub: Requisition for Permission to visit your Industry – Reg.

The Second year B.Tech. (EEF) of our Institution are interested to visit your industry
Sakthi Transformers, Chennai.

The visit of Industry will help the students to understand the practical knowledge in
their area of study.

Hence, it is requested that the permission may please be granted for the visit as per any
of the following dates given below.

Date : 25/09/2018 (or) 27/09/2018

No. of Students : 31



B.S. Abdur Rahman

Crescent

Institute of Science & Technology

Deemed to be University u/s 3 of the UGC Act, 1956

GST Road, Vandalur, Chennai 600 048

A STUDY ABOUT MANUFACTURING PROCESS OF TRANSFORMERS

An Industrial Visit to Sakthi Transformers

Submitted By:

THE STUDENTS OF EEE 2nd Year

DEPARTMENT OF ELECTRICAL AND ELECTRONICS ENGINEERING

B S ABDUR RAHMAN CRESCENT INSTITUTE OF SCIENCE AND TECHNOLOGY, CHENNAI

ACKNOWLEDGEMENT

We are thankful to Dr Y. Mohamed Shuaib, Assoc. Professor & HoD/EEE

Mr. S. Suresh, AP/EEE

Mrs. V. Baranigha, AP/EEE

This trip was of a great experience which gave a real exposure to the industry. It was highly beneficial for all students as it explained the theoretical and practical concepts both.

We are also thankful to all the instructors at Sakthi Transformers who provided the detailed explanations and helped us preparing short notes during the trip.

29 students of II year EEE and of B. S. Abdur Rahman Crescent Institute of Science and Technology visited Sakthi Transformers 25.09.2018.

Industrial Visit Report

On 25th SEPTEMBER, the Department of EEE organised an industrial visit to SAKTHI TRANSFORMERS, located in Kundratur, Chennai.

The visit was organised with prior permission. Mr. S. Suresh and Mrs. V. Bharanigha were the co-ordinators for this whole industrial visit.

DETAILS OF THE JOURNEY

- We left for the IV from the college campus at 9:30am via our non-AC college bus on 25th Sep 2018 along with our co-ordinators faculties with 29 students of EEE 2nd year.
- We reached Sakthi Transformers within an hour and we were taken inside to see the manufacturing process of transformers in two batches.
- Around 10 men were working constantly at that time and the in-charge greeted us and showed us around the factory.
- He then explained the various steps involves in assembling and manufacturing a transformer.
- First we saw two men assembling the laminated pieces of the transformer core which are made of silicon (manufactured in Japan).



- Behind them was a man winding a fixed no. of turns (as per order) of copper wire onto a circular structure made of wood, which will be mounted on the transformer core later.



- Most of the transformer core windings were done in such a way that the secondary winding was inscribed inside the primary winding.



- Sakthi Transformer professional also explained about the function of oil in the transformer, possible faults that occur and the reasons they occur.
- After the core was ready it is kept inside an oven to evaporate any moisture content it has.



- We learnt that there are many ways in which the primary and secondary windings are wound and the manufacturer like Sakthi Transformers manufactures the transformer based on orders they receive.
- Sakthi Transformers not only manufactures transformers but also offers service and repair.

- We were lucky to be there to observe a high capacity transformer that had come from Sairam University for repair.



- It had the feature of tap changing, which we didn't know what it was before; it had an (OLTC) On Load Tap Changer which is very useful as there is no need to cut the power supply to change the output voltage of the transformer.

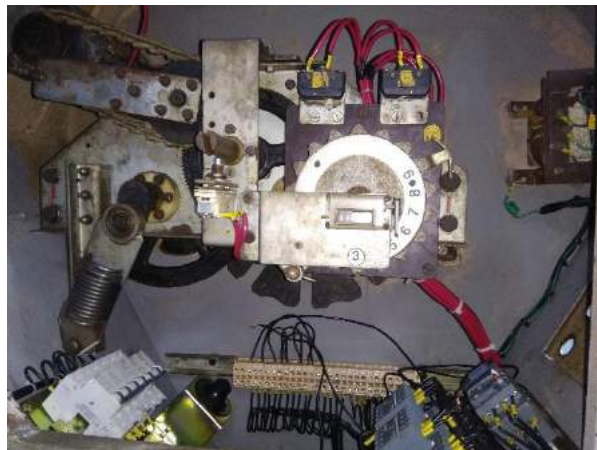

- It is used to regulate the output voltage of a transformer. It can be done automatically as well by programming it based on the Load needed.

Conclusion

- Each batch took about 20-30 minutes to complete the Industrial Visit.
- We are thankful to the department and faculty members for arranging this Industrial Visit.

Attendance

B. S. ABDUR RAHMAN CRESCENT INSTITUTE OF SCIENCE AND TECHNOLOGY

DEPARTMENT OF ELECTRICAL AND ELECTRONICS ENGINEERING

II YEAR EEE- 2017-21

Date: 25/09/2018

S.No.	RRN No.	Name of the Student	Signature
1	170041601001	ADITH SENTHIL KUMAR	-AB →
2	170041601002	ANWAR SADATH. S	Present
3	170041601003	ABARNA.R	Absent
4	170041601004	ARSHATH BILAL.R	Present
5	170041601006	N.M.GUGHAN	Absent
6	170041601007	JUNAIDMOHAMMED.M	Absent
7	170041601008	KANNAN.R	Absent
8	170041601009	KARTHIGA.K.R	Absent
9	170041601010	KEERTHI RANLR	Present
10	170041601011	KRITHIKA.H	Present
11	170041601012	MAHA HANIFA RABI	Absent
12	170041601013	M.MOHAMED ABUBACKAR SHIDDIK	Present
13	170041601014	MOHAMED ARSHAD.J	Present
14	170041601015	MOHAMED HANEEF.F	Present
15	170041601017	MOHAMED RIAZ.N	Present
16	170041601018	MOHAMMED SALLA	Absent
17	170041601019	MOHIT JAISINGH.M	Absent
18	170041601021	NIHAL	Absent
19	170041601022	SHAKSHAVALLP.S	Present
20	170041601023	RANGANATHAN.S	Present
21	170041601024	ROHITH.H	Absent
22	170041601025	SAJITH FARAS.S	Present
23	170041601026	SAKTHIKUMAR.G	Present
24	170041601028	SEYED MOHAMED SALIHU.M.N	Present
25	170041601029	SHAKIR HASSAN DAR	Present
26	170041601030	SHWETHA.K	Absent
27	170041601031	STEFFI CARVALHO	-AB →
28	170041601032	SYED MOHAMMED RAFIUDDIN.A	Present
29	170041601033	TAMBOLI ILIYAS YAKUB	Present
30	170041601035	FADHALULLAH INAYADULLAH	Present
31	170041601036	SATHIYASEELAN.M	Absent

27/21

Fwd: Approval for Industrial Visit from Crescent University - SANDS 11.04.19

HOD EEE <hodeeee@crescent.education>
To: Athbel Joe <athbeljoe@crescent.education>

Thu, Apr 11, 2019 at 3:59 PM

----- Forwarded message -----

From: **Training [SANDS]** <training@sandsindia.com>
Date: Thu, 11 Apr, 2019, 11:32 AM
Subject: Approval for Industrial Visit from Crescent University - SANDS 11.04.19
To: HOD EEE <hodeeee@crescent.education>
Cc: Marketing-Training [Sands] <mktg.trg@sandsindia.com>, admin stdc <sandstraining@sandsindia.com>

Dear Dr. Mohamed Shuaib,

Greetings from **Signals & Systems India Pvt. Ltd. (SANDS)**!We have approved your request for an industrial visit to our company on **16.04.2019 (Tuesday)**.

College: **B.S. Abdur Rahman Crescent Institute of Science and Technology**
Dept & Year: **EEE**
Total:

Visiting Fees: **N/A**Your timings will be from **9:30 am to 11:00 am (1 1/2 Hrs only)**.The exposure will mainly be in **IIOT, Embedded Systems & Big Data** for your Students.**Programme Schedule:-**

- 1) Introduction to Industry & Company
- 2) Introduction to Internet of Things & Big Data
- 3) **SANDS** Product demo for 3-4 Nos for 5-7 minutes each
- 4) Discussion & Clarification about technology to students & Staffs
- 5) Departmental Visits

Note: Please find attached the rules and regulations for visiting our company premises.Please send us a reply on this email as a confirmation. For further clarifications, please call **9003262765, 8754546090 or 358216134**.

--
Thanks & Regards,
Ramani Esther Samuel
Counsellor

CEREBRO  **INNOVATIONS**
Elevate to the Tipping Point

15/D-19, SIPCOT I.T Park, Siruseri, Chennai - 603103.
Mob: +91- 8754546090
Landline : 044 - 27470001, 27470003, 27470087, 27470088
Email: training@sandsindia.com
Website : www.sandsindia.com
www.cerebroinnovations.com

On Thu, Apr 11, 2019 at 9:34 AM HOD EEE <hodeeee@crescent.education> wrote:

Dear Sir,
Greetings.

The students from the department of Electrical and Electronics Engineering are interested in visiting the SANDS facility, Chennai. I kindly request you to permit our students for a visit to learn about the activities of SANDS on a day next week (preferably on Tuesday 16.04.2019).

Regards



B.S. Abdur Rahman

Crescent

Institute of Science & Technology
Deemed to be University u/s 3 of the UGC Act, 1956
GST Road, Vandalur, Chennai 600 048

Dr. Y. Mohamed Shuaib
Head of the Department
Department of Electrical and Electronics Engineering
B.S. Abdur Rahman Crescent Institute of Science and Technology,
Vandalur,
Chennai - 600048



B.S. Abdur Rahman

Crescent

Institute of Science & Technology

Deemed to be University u/s 3 of the UGC Act, 1956

FIELD VISIT REPORT

M/s. Signals and Systems India Pvt.Ltd (SANDS),
Siruseri ,Chennai, Tamil Nadu

By

IV Year Students of B.Tech. (EEE)

Date of visit : 16.04.2019

No of students : 29

Arranged by

Dr. Y. Muhamed Shuaib, HoD/EEE

Faculty Co-ordinators

Mr. Athebel Joe, AP/EEE & Mr. Suresh, AP/EEE

INTRODUCTION

The SANDS is at SIPCOT, Siruseri. They offer services like Meter Reading using CMRI, with special provisions of Photo + GPS for manual cases. Meter Accuracy Testing, MF verification Simultaneous testing of Primary & Secondary Connections.

PROGRAMME SCHEDULE

- 1) Introduction to Industry & Company
- 2) Introduction to Internet of Things & Big Data
- 3) SANDS Product demo for 3-4 Nos for 5-7 minutes each
- 4) Discussion & Clarification about technology to students & Staffs
- 5) Departmental Visits

PRODUCTS DEMONSTRATED

Instruments for Meter Reading
Reference standard meter
GPS time server,
Automatic Meter Reading,
Feeder Remote Terminal Unit

CMRI

Common Meter Reading Instrument (CMRI) is a hand held computer used to download data from electronic tri-vector meters, supporting different protocols like IEC, ANSI and PACT. CMRI is also compliant to IS-15959/ DLMS (IEC-62056) standard. CMRI can be interfaced with portable printer for Spot Billing applications.

OPAL

OPAL is a hand held computer used to download data from electronic tri-vector meters, supporting different protocols like IEC, ANSI and PACT. OPAL can be interfaced with portable printer for Spot Billing applications. OPAL comes with Linux Operating system. OPAL is available with memory sizes ranging from 128 MB to 8 GB.

GPS Time Server

GPS Time Server – SYNTIME is a sleek 1U, 19” rack mountable GPS Time Server. It is to synchronize and maintain the timing and frequency requirement of power and process industry equipment.

ENERGY MANAGEMENT SYSTEM

Industries with good Energy Management practices have a distinct competitive edge over others. Energy Usage reports help customers to identify energy saving opportunities and save cost Bill Audit allows industries to check the correctness of Utility Billing.

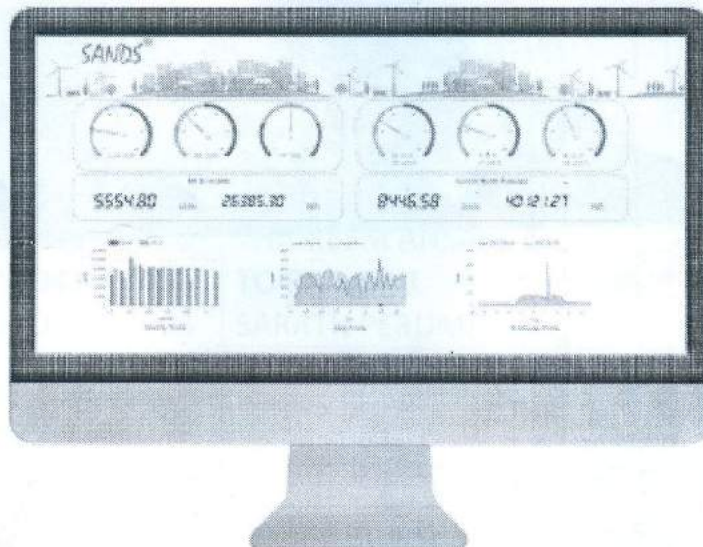

SUMMARY

SANDS manufactures a wide range of niche products, for use in energy sector, with focus on reduction of commercial loss, and energy / demand management system. All products employ state-of-art embedded technology, and are tested to international standards.



Co-ordinator

HOD/EEE

Annexure

List of Students Who Visited

RRN	Name
150041601002	ABDUL KADER
150041601003	ABDUL RAHMAN. A
150041601004	ABINAYA. V
150041601006	AHMAD RIZWAN
150041601010	DHIVYA. P
150041601011	FAHAD AYUB. P.M
150041601012	FAYAS AHAMED. N.K
150041601013	GANAPATHY SIVAM. C
150041601015	KADER
150041601017	MADHUMITHA. S
150041601020	MOHAMED AMRULLAH. S
150041601025	MOHAMED SHAHUL HAMEED. S.S
150041601026	MOHAMMED ARSHATH. K
150041601029	NAVEENKUMAR. N.S
150041601031	PONNI @ SURYA. S
150041601032	PRABHAVATHY. R
150041601033	SAFRIN. S
150041601036	SARA NEHA. M.H
150041601037	SESHA KANNAN. G
150041601042	SIRAJUDDEEN SAIFUDDEEN
150041601044	SRIRAM. S
150041601047	VIGNESH. S
150041601048	VINITHA. T
150041601049	WAHITH. A
150041601050	MOHAMED TAFIDANSARI. A
150041601052	AHMED FARZEEN. T.K
150041601053	THAMEEM ANSARI. G
150041601055	TOIBA NISAR
150041602003	SARATH PERUMAL. J

Co-ordinator

HOD/EEE

DEPARTMENT OF ELECTRONICS & INSTRUMENTATION ENGINEERING

INDUSTRIAL VISIT REPORT

Industrial visit to Tvs Training and Services Centre ,Ambattur



We, the third year students of EIE department accompanied by our faculty Mrs. Anitha and a dept. staff Mr. Yuvaraj visited the above industry on 5th February, 2019.

Initially there was a demo session regarding PLC's of various companies like Delta, Mitsubishi, Omron and Siemens. Also about VFD (Variable frequency drive), SCADA and HMI (Human manual interface). After these sessions we had a demo on PNEUMATIC AND HYDRAULIC processes. We heeded on to a presentation on EMBEDDED SYSTEMS by their staff, Mrs. Sivaranjini. She explained us the various real time applications such as Home Automation using rack and pinion, Automated parking slot and Laser cutting. She gave us a detailed information of the past, present and the future developments of Embedded systems. The laboratory had a division of Hardware and Firmware was students from various colleges were under training.



DEPARTMENT OF ELECTRONICS & INSTRUMENTATION ENGINEERING

Thereafter at 1a.m we were assembled for a complete presentation regarding the industry by Mr.Muneeswaran. He shed light on the various policies and training programmes offered at their industry for industrial employees, diploma students and also graduates.



We had a great time there. Thanks to the Department of EIE.

Submitted by
Zubaidha
ZUBAIDHAM
160061601030

Third year EIE



B.S. Abdur Rahman

Crescent

Institute of Science & Technology
Deemed to be University u/s 3 of the UGC Act, 1956
GST Road, Vandavur, Chennai 600 048

B.Tech-Electronics and Instrumentation Engineering- VI Semester

1.	160061601001	ABHISHEK R
2.	160061601002	ABHUHASEEM M
3.	160061601003	ALISTAIR VIVIAN THOMPSON
4.	160061601004	ARSHATH B
5.	160061601005	ASHWINTH J
6.	160061601007	BHUVANESH G
7.	160061601008	FAZIL AHAMED M J
8.	160061601009	HARISHANKAR K
9.	160061601010	JOTHEESWARAN
10.	160061601011	MOHAMED HARISH M
11.	160061601012	MOHAMED IRFAN S
12.	160061601013	MOHAMED MADHURUS H
13.	160061601014	MOHAMED NOUFAL ANWAR J
14.	160061601015	MOHAMED RAFEEQ S
15.	160061601016	MOHAMED TARIQ HUSSAIN P M
16.	160061601017	MOHAMMED FAIZAN
17.	160061601018	NAVEED AHAMED M J
18.	160061601019	PAVAN KUMAR V
19.	160061601020	SAIRAM R
20.	160061601022	SHAMEERA BANU L
21.	160061601023	SHARIQ NAVEETH M A
22.	160061601024	SHEIKMOHAMED S
23.	160061601025	SHIR SABESAN T
24.	160061601026	SUBAIDHA FATHIMA M
25.	160061601028	SYED SUHAIL I
26.	160061601029	VISHAL K
27.	160061601030	ZUBAIDHA M
28.	160061601031	MOHAMMED ASHIQ.N
29.	160061601032	NORMAN CRUZ.S
30.	160061601033	MOHAMED MUBEEN
31.	160061602001	MOHAMED ABDUL KADER A

Visited TNSAT
on 05/02/19

(B.S.A.R)

HOD/EIE
5/2/19



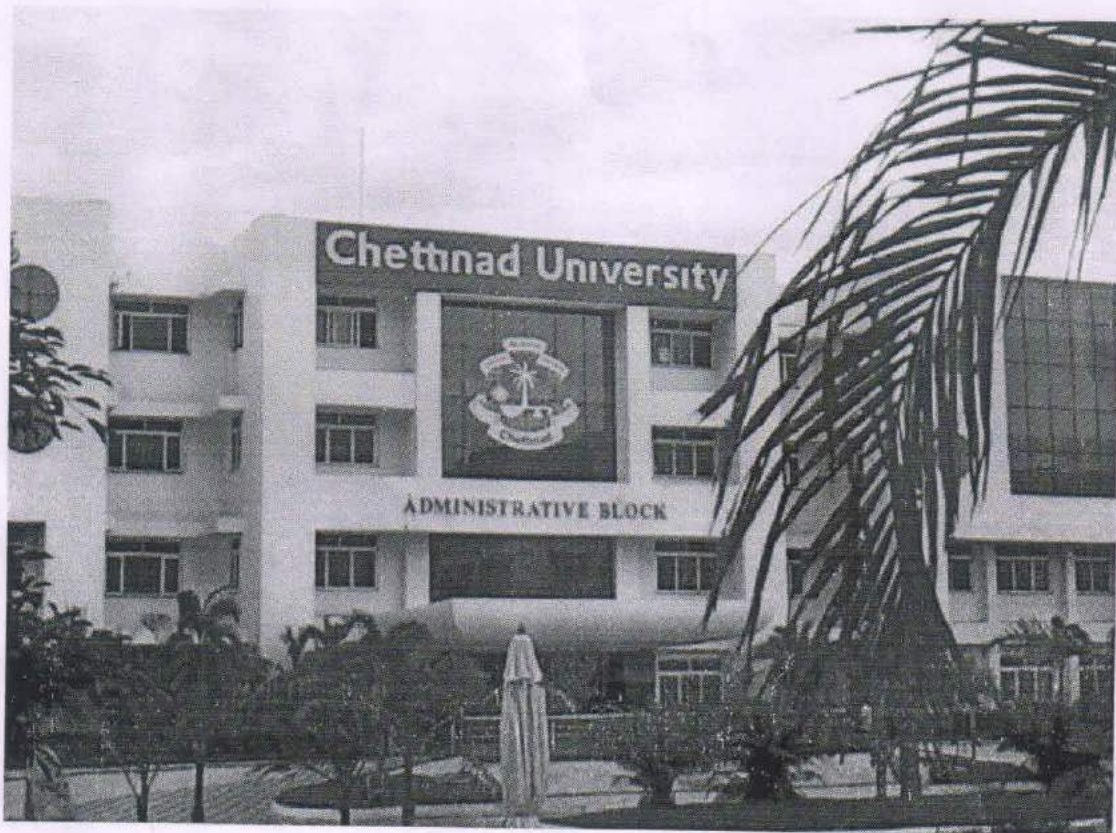

Chettinad Super Speciality Hospital Visit

EIBX01 Biomedical instrumentation, III year EIE

on

31.10.2018

[Handwritten Signature]
14/11/18
Course co-ordinator

[Handwritten Signature]
HOD/EIE
14/11/18

We, 7 students of third year EIE who had taken Biomedical Instrumentation as Elective course reached Chettinad Super Speciality Hospital around 10.30a.m on 31.10.18. We were accompanied by Dr.D.Najumnissa Jamal, Professor EIE, and our course faculty for the visit.

Working of Various medical equipments like X-rays, CT Scan, MRI, Dialysers, Patient Monitoring equipments like ECG, Multipara monitor, Defibrillators, Diathermy, and physiotherapy equipments had been demonstrated

ECG MACHINE



The electrocardiogram also referred to as ECG, 12-lead ECG, or EKG, is a non-invasive diagnostic test that evaluates your heart's electrical system to assess for heart disease. It uses flat metal electrodes placed on the chest to detect the electrical charges generated by the heart as it beats, which are then graphed. The doctor can analyze the patterns to get a better understanding of your heart rate and heart rhythm, identify some types of structural heart disease,

It is highly diagnostic method as it represents data in topographic form.

It is highly informative and provide informations such as chest pain, shortness of breath, abdominal pain etc., It can detect any silent cardiac condition which could be result of surgery and anesthesia. It analyzes signal from heart and produces result in graphical form. It is safe method. It is inexpensive method. It is easy to perform.

CT SCAN:

A computerized tomography (CT) scan combines a series of X-ray images taken from different angles and uses computer processing to create cross-sectional images, or slices, of the bones, blood vessels and soft tissues inside our body. People often have CT scans to further evaluate an abnormality seen on another test such as an X-ray or an ultrasound. They may also have a CT to check for specific symptoms such as pain or dizziness. People with cancer may have a CT to evaluate the spread of disease

We, 7 students of third year EIE who had taken Biomedical Instrumentation as Elective course reached Chettinad Super Speciality Hospital around 10.30a.m on 31.10.18. We were accompanied by Dr.D.Najumnissa Jamal, Professor EIE, and our course faculty for the visit.

Working of Various medical equipments like X-rays, CT Scan, MRI, Dialysers, Patient Monitoring equipments like ECG, Multipara monitor, Defibrillators, Diathermy, and physiotherapy equipments had been demonstrated

ECG MACHINE



The electrocardiogram also referred to as ECG, 12-lead ECG, or EKG, is a non-invasive diagnostic test that evaluates your heart's electrical system to assess for heart disease. It uses flat metal electrodes placed on the chest to detect the electrical charges generated by the heart as it beats, which are then graphed. The doctor can analyze the patterns to get a better understanding of your heart rate and heart rhythm, identify some types of structural heart disease,

It is highly diagnostic method as it represents data in topographic form.

It is highly informative and provide informations such as chest pain, shortness of breath, abdominal pain etc., It can detect any silent cardiac condition which could be result of surgery and anesthesia. It analyzes signal from heart and produces result in graphical form. It is safe method. It is inexpensive method. It is easy to perform.

CT SCAN:

A computerized tomography (CT) scan combines a series of X-ray images taken from different angles and uses computer processing to create cross-sectional images, or slices, of the bones, blood vessels and soft tissues inside our body. People often have CT scans to further evaluate an abnormality seen on another test such as an X-ray or an ultrasound. They may also have a CT to check for specific symptoms such as pain or dizziness. People with cancer may have a CT to evaluate the spread of disease

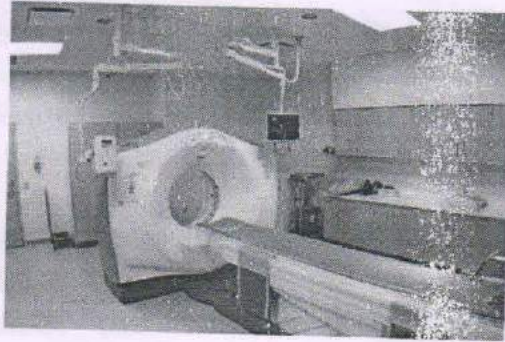

Of all the internal imaging procedures available to physicians, the CT scan is the most detailed, and can give a doctor the most complete picture of what's happening inside a patient's body. They are particularly useful and widely used in diagnosing cancer.

MRI

Magnetic resonance imaging (MRI) is a type of scan that uses strong magnetic fields and radio waves to produce detailed images of the inside of the body. An MRI scanner is a large tube that contains powerful magnets. You lie inside the tube during the scan. An MRI scan can be used to examine almost any part of the body, including the:

brain and spinal cord, bones and joints, breasts, heart and blood vessels, internal organs, such as the liver, womb or prostate gland. The results of an MRI scan can be used to help diagnose conditions, plan treatments and assess how effective previous treatment has been.

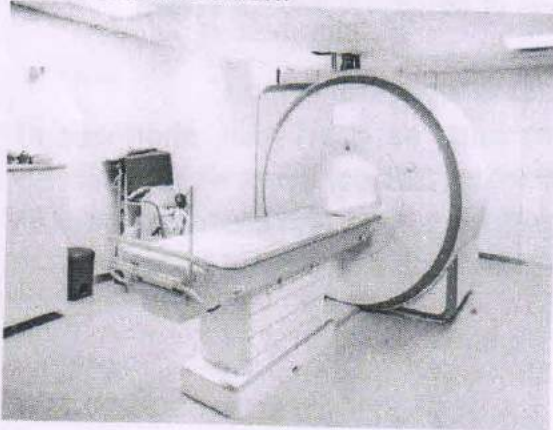

MRI Machine

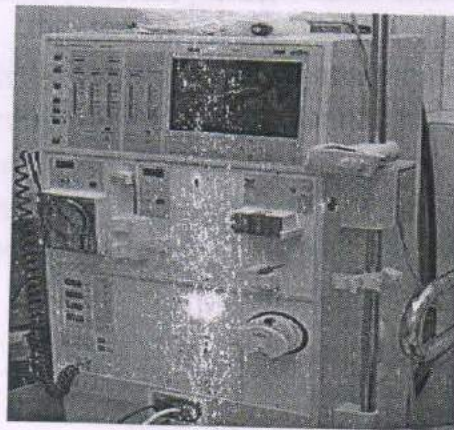

dialysis machine

DIALYSERS

The **dialysis machine** mixes and monitors the dialysate. Dialysate is the fluid that helps remove the unwanted waste products from your blood. It also helps get your electrolytes and minerals to their proper levels in your body. The **machine** also monitors the flow of your blood while it is outside of your body.

Some advantages to the use of this dialyzer are its low resistance to blood flow. Because of this fact, there is not as much need for the use of an anti-blood clotting solution. Another advantage of this dialyzer is that its filtration rate is controllable and predictable. The next advantage of this dialyzer is the amount of blood contained within the dialyzer is relatively low. The less blood that is out of the body at one point in time, the better the dialyzer. The final advantage of the parallel plate dialyzer is that it is inexpensive.

MAMMOGRAPHY



Mammography is specialized medical imaging that uses a low-dose x-ray system to see inside the breasts. A **mammography** exam, called a **mammogram**, aids in the early detection and diagnosis of breast diseases in women.

Advantages. Screening often allows for the detection of cancers at an early stage of development. Treatment is then possible without chemotherapy. The vast majority of women (nearly 98 %) will not have breast cancer if their **mammograms** and additional examinations do not reveal cancers

- Reduces the risk of dying from breast cancer
- Reduces the risk of having to undergo chemotherapy
- Allows women to know the health of their breasts

X RAY MACHINE

Projection radiography (Conventional radiography)- most common used method of medical imaging that utilizes x-rays. Conventional Radiograph- represents a projection of the 3D volume of the body onto a 2D imaging surface. Conceptually, the projection radiograph represents the transmission of the x-ray beam through the patient weighted by integrated loss of beam energy due to scattering and absorption in the body.

Projectional radiograph

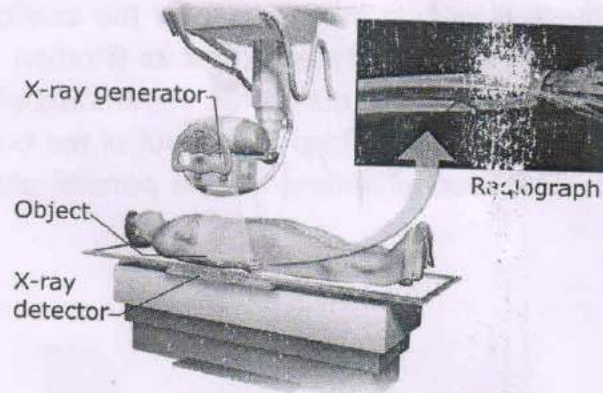

Advantages

- Short exposure time (0.1 second), Production of a large area image (e.g. 14x17 in.), Low cost, Low radiation exposure (30 mR for a chest radiograph, equivalent to 1/10 of the annual background dose), Excellent contrast and spatial resolution

DEFIBRILATOR

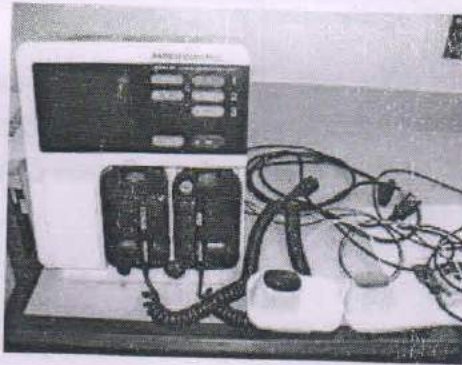

Sudden cardiac arrest (SCA) can happen at any time, to anyone, of any age, in any location. When a person collapses in SCA, minutes count. A person in SCA is not breathing and their heart has stopped beating. Performing immediate CPR (Cardiopulmonary Resuscitation) can keep a person's brain and heart alive, until definitive care arrives. In addition to performing CPR quickly, using an AED (Automated External Defibrillator) can give this person the best possible chance to survive!

AEDs are small portable devices which can deliver an electric shock to a person's heart. This shock can help to stop abnormal electrical impulses in the heart and allow it to return to a normal beating rhythm. The combination of CPR and AED use can literally

bring a person back to life. Without early CPR and AED use, only about 2.5% percent of SCA victims survive. But the initiation of early CPR and AED use within **minutes** can **raise a victim's chance of survival to almost 80%**.

DIATHERMY

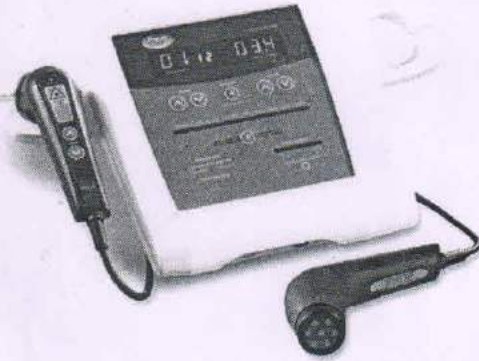

Diathermy is a therapeutic treatment commonly prescribed for muscle and joint conditions. It uses a high-frequency electric current to stimulate heat generation within body tissues.

The heat can help with various processes, including:

- increasing blood flow
- relieving pain
- improving the mobility of tissues as they heal

Shortwave diathermy uses high-frequency electromagnetic energy to generate heat. It may be applied in pulsed or continuous energy waves. It has been used to treat pain from kidney stones, and pelvic inflammatory disease. It's commonly used for conditions that cause pain and muscle spasms such as: sprains, strains, bursitis, tenosynovitis

Microwave diathermy uses microwaves to generate heat in the body. It can be used to evenly warm deep tissues without heating the skin. Since it can't penetrate deep muscles, it's best suited for areas that are closer to the skin, such as the shoulders.

Ultrasound diathermy uses sound waves to treat deep tissues. Heat is generated by the vibration of the tissue. This promotes blood flow into the area. Ultrasound diathermy is used for: musculoskeletal sprains, strains, muscle spasms, joint contractures or adhesions, neuromas



B.S. Abdur Rahman
Crescent
Institute of Science & Technology

Deemed to be University u/s 3 of the UGC Act, 1956

ACCREDITED WITH "A" GRADE BY NAAC

DEPARTMENT OF ELECTRONICS AND INSTRUMENTATION ENGINEERING

Lr. No.: 09/2018/ BSACIST/EIE/Industrial Visit

Date: 25.10.2018.

To
The Registrar
Chettinad Health City
Rajiv Gandhi Salai,
Kelambakkam,
Kanchipuram Dist,
Chennai, Tamil Nadu 603103

Sir,

Sub: Permission for Visit to Chettinad Health City – Reg.

We are arranging field trips for our Third year students of Electronics & Instrumentation Engineering branch to familiarize with practical aspects. In this connection a visit to Chettinad Health City would be of immense benefit and relevance to them.

The details are given below:

No. of Students : 8
No. of Staff : 1
Date : 30th October or 1st November , 2018
(Any one day as per your Convenience)

We request you to kindly give them necessary permission for the visit as per your convenience.

Thanking you,

Dr. D. Najumnissa Jamal
Mobile No 9444774486
Coordinator

Yours Sincerely

HOD / EIE
25/10/18



Chettinad

Academy of Research & Education
(Deemed to be University Under sec. 3 of the UGC Act 1956)

Interoffice Communication

Ref.No.665/Regr./AR-Admin/2018

Dated 30.10.2018

Sub: Chettinad Academy of Research and Education – Other institution students visit to Chettinad Health City – B.S. Abdur Rahman Crescent Institute of Science and Technology - Department of Electronics and Instrumentation Engineering- for the purpose of practical aspects- permitted-regarding.

Ref: Letter No. 09/2018/BSACIST/EIE/Industrial visit dated 25.10.2018 received from the HoD/EIE-coordinator.

With reference to the above letter, permission is hereby granted to third year students of department of Electronics and Instrumentation Engineering B.S. Abdur Rahman, Crescent Institute of Science and Technology Vandalur Chennai for a industrial visit to Chettinad Health City on 01.11.2018. This permission is restricted to 8 students guided by one faculty. The Faculty/students may contact the following officer and get instructions before visiting the areas in their field of study.

Mr. Manickam, Head-Infrastructure
Mobile No. 9094961000

A sum of Rs.1,000/- + 18 % GST=Rs.1,180/- (Rupees One thousand one hundred and eighty only) may be collected as visiting charges.

1. They will not be allowed to take photographs / videographs.
2. They should not violate the rules and regulations of the Chettinad Academy of Research and Education.
3. They are permitted to act on the Head of the Department instructions in the hospital.
4. They are also instructed that if any damage occurs, the cost shall have to be reimbursed by them.

The Head-Infrastructure is requested to inform the college accordingly.

S. Jeyendrasaswathi
Registrar

To
The Head-Infrastructure

Copy to:
1. The Finance Officer
2. The AGM (Admin)

Copy submitted to the Vice Chancellor

Rajiv Gandhi Salai, Kelambakkam, Kancheepuram Dist. 603 103. India

T +91-44-4741 1000, F +91-44-4741 1011 Mail : care@chettinadhealthcity.com Web : www.chettinadhealthcity.com

B. TECH & ELECTRONICS AND INSTRUMENTATION ENGINEERING

EIBX01 & BIOMEDICAL INSTRUMENTATION

FIELD VISIT TO CHETTINAD HOSPITALS, KELAMBAKKAM ON 31.10.18

ATTENDANCE

RRN	NAME	SIGNATURE
160061601011	MOHAMMED HARISH. M	M. Mohammed Harish
160061601019	PAVAN KUMAR. V	ABSENT.
160061601020	SAIRAM. R	Sairam
160061601022	SHAMEERA BANU. L	Shameera Banu
160061601026	SUBAIDHA FATHIMA. M	Subaidha Fathima
160061601030	ZUBAIDHA. M	Zubaidha
160061601031	MOHAMMED ASHIQ. N	Mohammed Ashiq
160061601032	NORMAN CRUZ. S	S. Norman Cruz

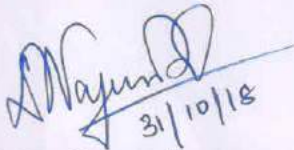
31/10/18

Course Co ordinator
D. Nayyassmina



DEPARTMENT OF ELECTRONICS AND INSTRUMENTATION ENGINEERING

INDUSTRIAL VISIT REPORT

Date: 3.11.18

On 29th October 2018, we the pre-final year students of Electronics and Instrumentation engineering went for an industrial visit to **SANDS**, Siruseri, OMR, Chennai.

Signals And Systems (India) Private Limited better known in the industry with Brand name as **SANDS** is an 21 Years old manufacturing company and they manufacture a wide range of niche products, for use in energy sector, with focus on reduction of commercial loss, and energy / demand management system.

SANDS conduct various training programs in Embedded Systems, with focus on bridging the gap between the university curriculum and industry's requirement for ready-to-design engineers. SANDS plans to commence engineering services in Embedded Systems, covering the design, development and manufacture. The services will include Systems Architecture Design, Hardware Engineering, Software Development, Prototyping and Testing, in Embedded Systems, Microcontroller, IoT and Data Analytics verticals. They also provide various internships and workshops on ARM Cortex M0+, Raspberry Pi, Robotics, Arduino, Java, Big Data etc.

As part of our Industrial visit we were shown the manufacturing process of 3 different products namely **CMRI-COMMON METER READING INSTRUMENT, FRTU-FEEDER REMOTE TERMINAL UNIT & THREE PHASE REFERENCE STANDARD METER -TPRS.**





CMRI- COMMON METER READING INSTRUMENT



Common Meter Reading Instrument (CMRI) is a hand held computer used to download data from electronic tri-vector meters, supporting different protocols like IEC, ANSI and PACT. CMRI is also compliant to IS-15959/ DLMS (IEC-62056) standard. CMRI can be interfaced with portable printer for Spot Billing applications. SANDS CMRI-1010 comes with LCD Graphical (3.5" TFT) & 15Line x 40 Characters visibility is rugged to withstand drop on to concrete and water proof. CMRI is available with memory sizes ranging from 128 MB to 8 GB.

FRTU-FEEDER REMOTE TERMINAL UNIT

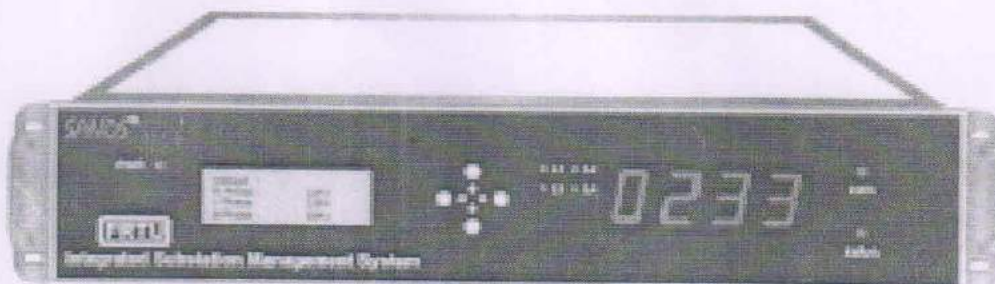

The FRTU system should be able to monitor all the sub-station equipment should acquire all parameters in respect of all incoming and outgoing feeders on real-time basis and the status signals of the devices. The overall system needs planning and execution, forecasting and implementation, maintenance etc. Energy supply is to be balanced with the load demand continuously under normal and abnormal situations such as loss of generation, equipment failures, Line faults, peak loads, load shedding etc to maintain system stability, reliability and availability.



CMRI- COMMON METER READING INSTRUMENT



Common Meter Reading Instrument (CMRI) is a hand held computer used to download data from electronic tri-vector meters, supporting different protocols like IEC, ANSI and PACT. CMRI is also compliant to IS-15959/ DLMS (IEC-62056) standard. CMRI can be interfaced with portable printer for Spot Billing applications. SANDS CMRI-1010 comes with LCD Graphical (3.5" TFT) & 15Line x 40 Characters visibility is rugged to withstand drop on to concrete and water proof. CMRI is available with memory sizes ranging from 128 MB to 8 GB.

FRTU-FEEDER REMOTE TERMINAL UNIT

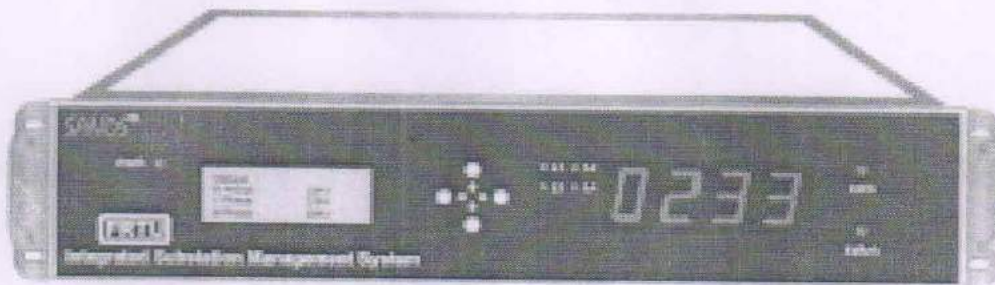

The FRTU system should be able to monitor all the sub-station equipment should acquire all parameters in respect of all incoming and outgoing feeders on real-time basis and the status signals of the devices. The overall system needs planning and execution, forecasting and implementation, maintenance etc. Energy supply is to be balanced with the load demand continuously under normal and abnormal situations such as loss of generation, equipment failures, Line faults, peak loads, load shedding etc to maintain system stability, reliability and availability.



The application of FRTU principles lead to automatic data logging, sub-station level control. Energy management, load forecasting etc. Scheduling eventually to sub-station automation. The electrical networks are frequently being expanded and reinforced resulting in more complex networks. Hence, energy transportation, monitoring and control to achieve an economical and operational efficiency requires an ongoing penetration of the grid down to the lowest level and implementation of a viable FRTU system is imperative. The system should be comprehensively self monitored and faults will be immediately indicated to the operator possible before they develop into serious situations. Such faults are recorded as faulty status in a system.

The display should cover the status of the entire substation including all switchgear and communication links. Dynamic coloring of SLD with load schedule, power factor, voltage, power etc. This system is a replacement for SCADA system. In existing SCADA system data collection module is in Linux SBC and SBC sends the data to HMI, HMI uses these data for further process.

THREE PHASE REFERENCE STANDARD METER -TPRS

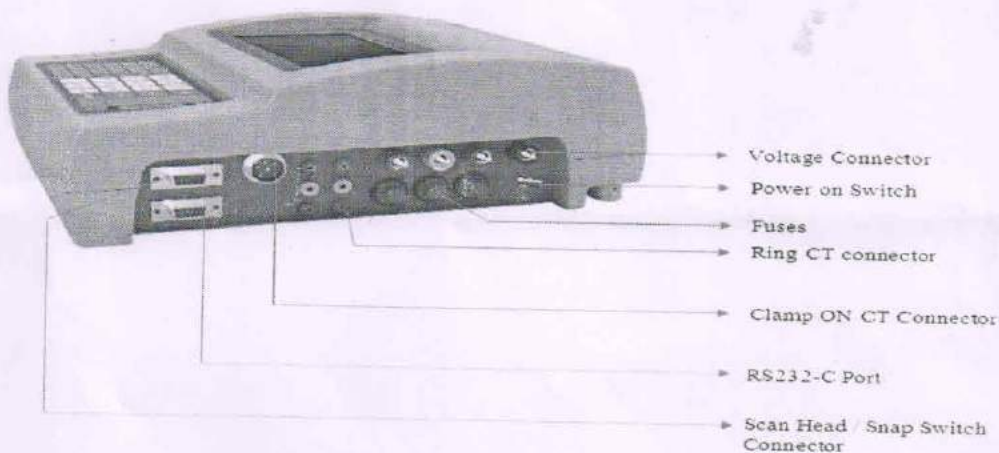

The three phase reference standard meter (TPRS-1107) from SANDS is portable equipment. The main objective of this device is to calibrate the errors in three-phase and single-phase energy meters i.e. the meter under test (MUT). The TPRS supports both static and electro-mechanical types of meters. It can also be used to compute the voltage, current, energy, power factor etc of the meter under test. It has an LCD display, an alphanumeric keypad that makes it easy for the user to operate the TPRS

SUBMITTED BY

MOHAMMED FAIZAN, 160061601017

III year V sem EIE



anidhag EIE <anidhag@crescent.education>

III year EIE - V Sem.

seeking permission to visit your organisation**Surendar Marketing-Training [Sands]** <mktg.trg@sandsindia.com>

Wed, Oct 24, 2018 at 9:49 AM

To: anidhag@crescent.education

Cc: Training Sands <sandstraining@sandsindia.com>, Site office Training <training@sandsindia.com>, "P Karthik Venkatesh [Sands]" <p.karthikvenkatesh@sandsindia.com>

Dear Ms. G.Anitha,

Greetings From SANDS!!!

With reference to the trailing mail, We herewith **Approve** the **Industrial visit for the total maximum 30 students B.Tech. E&I Dept., along with 2 Staff's Members from B.S.A. Crescent Institute of Science & technology, on 29th Oct 2018 (Monday)**

Your Timing shall be from 10:00 am to 11:30am (1 1/2 Hrs only)

The exposure shall be mainly in **Embedded, IIOT & BIGDATA** for your Students.

Program Schedule:-

- 1) Introduction to Industry & SANDS Products,
- 2) Introduction to Internet of Things & Big Data.
- 3) SANDS Product demo for 3-4 Nos. for 5-7 minutes each
- 4) Discussion & Clarification about technology to students & Staffs
- 5) Tea Break
- 6) Departmental Visits

Please do call the undersigned for any further clarifications.

Kindly send your confirmation by mail.

Good day...

Thanks & Regards,
K.Surendar
Marketing Engineer

SANDS®

SIGNALS & SYSTEMS (India) Pvt. Ltd.
15/D-19, SIPCOT I.T Park, Siruseri, Chennai - 603103.
Mob: +91- 9003262765, 9841718045 (WhatsApp)
Landline : 044 - 27470001, 27470003, 27470087, 27470088
Email: mktg.trg@sandsindia.com
Website : www.sandsindia.com
www.sandscerebro.com

[Quoted text hidden]

SANDS Learning Division.pdf
395K

**A STUDY ABOUT BIOMEDICAL INSTRUMENTS
INDUSTRIAL VISIT to THE HAMEED HOSPITAL,
THIRUVANNAMALAI, 2.2.19**

A REPORT-2019

Submitted by

**ABHINESHJAYRAM M
GOUTHAM S**

**170061601001
170061601008**

Faculty Accompanied

**Dr. D. Najuminissa Jamal
Ms. M.S. Murshitha Shajahan**

DEPARTMENT OF ELECTRONICS AND INSTRUMENTATION ENGINEERING



B.S. Abdur Rahman

Crescent

**Institute of Science & Technology
Deemed to be University u/s 3 of the UGC Act, 1956
GST Road, Vandalur, Chennai 600 048**

We the second year students of ELECTRONICS AND INSTRUMENTATION ENGINEERING DEPARTMENT along with Dr. D.Najumnissa Prof / EIE, course teacher and Ms.M.S. Murshitha Shajahan, Class Advisor went for an INDUSTRIAL VISIT to HAMEED HOSPITAL, Thiruvannamalai on 02.02.2019 (SATURDAY).

We visited the hospital and gone through many Biomedical Instruments in the hospital. We learnt a lot during this visit about many instruments that are used in medical field. We have mentioned the equipments we have seen in the hospital below in the report.



First we were given refreshments at the Hospital and we were taken to the Physiotherapy department, X- Ray centre, Ultrasound Centre and diagnostic Laboratory. There the following instruments were demonstrated and some with a patients also.

Diathermy

Diathermy is electrically induced heat or the use of high-frequency electromagnetic currents as a form of physical therapy and in surgical procedures. The earliest observations on the reactions of high-frequency electromagnetic currents upon the human organism were made by Jacques Arsene d'Arsonval. The field was pioneered in 1907 by German physician Karl Franz Nagelschmidt, who coined the term *diathermy* from the Greek words *dia* and *θέρμη* *therma*, literally meaning "heating through". Diathermy is commonly used for muscle relaxation, and to induce deep heating in tissue for therapeutic purposes in medicine. It is used in physical therapy to deliver moderate heat directly to pathologic lesions in the deeper tissues of the body.

How does diathermy machine work?

Diathermy uses high-frequency electric current to produce heat deep inside a targeted tissue. It can reach areas as deep as two inches beneath the skin's surface.

The diathermy machine does not apply heat directly to the body. Instead, the waves generated by the machine allow the body to generate heat from within the targeted tissue. Diathermy is usually part of a complete physical therapy or rehabilitative regimen. Frequency and length of treatments vary.



Traction Machine

Traction refers to the set of mechanisms for straightening broken bones or relieving pressure on the spine^[1] and skeletal system. There are two types of traction: skin traction and skeletal traction. They are used in orthopedic medicine.

How does Traction machine works?

As the name implies, a traction machine applies traction to the spinal column. Depending on where the pathology is, traction can be applied to both the lower back and the neck. This is usually done by wrapping a harness around the lower back or under the chin and base of skull. The harness is then attached to the machine that pulls at a controlled speed, rate and weight as set by the physiotherapist. Imagine the neck pulling in one direction by the traction machines and the body weight acting as a counter force. This results in the "lengthening" of the cervical spine.

As the spinal structures are gently pulled away from each other, the pressure within the structures such as the disc reduces, and the space from which nerves exit the spinal cord increases. Therefore, traction is suitable for conditions with compressive stress within the spinal structures like disc prolapses and nerve impingements.

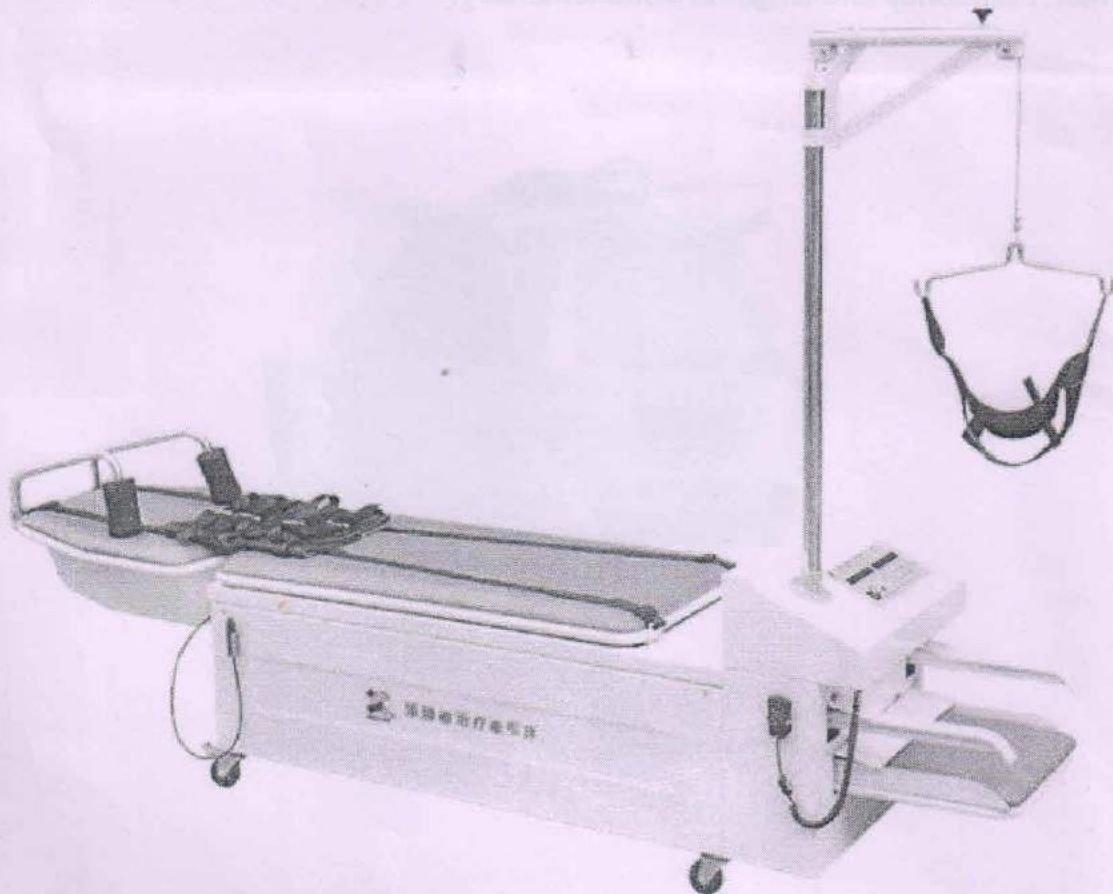

Electrical Nerve Stimulator

Electrical stimulation is sometimes given to patients with facial palsy. The facial nerve normally emits electrical impulses to give muscles their tone and shape. When the facial nerve is damaged the muscle no longer receives these messages and as a result the muscles become weak and floppy. External electrical stimulation can try and mimic these electrical impulses and help restore muscle tone. The nerve stimulation for a person with facial palsy due to the cold weather was demonstrated



X rays machine

X-ray imaging begins with a beam of high energy electrons crashing into a metal target and x-rays are produced. A filter near the x-ray source blocks these low energy rays, which means only the high energy rays pass through a patient toward a sheet of photographic film. X-ray can penetrate liquids, gas and solids. The point of penetration is based on the intensity, quality and wavelength of the X-ray beams. The stronger the beam of X-ray the more it will material it can penetrate, and vice versa. These electromagnetic radiations or X-ray work on the absorption of low level radiation by parts of our body with higher density, making the radiation not absorbed hit the photographic 'plate' to form a 'negative image'. This means the waves of X-ray can penetrate through materials of light atoms, such as flesh that is why flesh is not seen during imaging with X-rays. Bones, which are heavier atoms than flesh (due to the calcium in them), absorb the X-rays. The absorbed X-rays by the bones then glow on the photographic film. Meaning the higher the density of the material the brighter it will be imaged on the photographic film.



Ultra Sound

Medical ultrasound (also known as **diagnostic sonography** or **ultrasonography**) is a diagnostic imaging technique based on the application of ultrasound. It is used to create an image of internal body structures such as tendons, muscles, joints, blood vessels, and internal organs. Its aim is often to find a source of a disease or to exclude pathology. The practice of examining pregnant women using ultrasound is called obstetric ultrasound, and was an early development and application of clinical ultrasonography.

Ultrasound refers to sound waves with frequencies which are higher than those audible to humans ($>20,000$ Hz). Ultrasonic images, also known as sonograms, are made by sending pulses of ultrasound into tissue using a probe. The ultrasound pulses echo off tissues with different reflection properties and are recorded and displayed as an image. Many different types of images can be formed. The commonest is a B-mode image (Brightness), which displays the acoustic impedance of a two-dimensional cross-section of tissue. Other types can display blood flow, motion of tissue over time, the location of blood, the presence of specific molecules, the stiffness of tissue, or the anatomy of a three-dimensional region.

Compared to other dominant methods of medical imaging, ultrasound has several advantages. It provides images in real-time and is portable and can be brought to the bedside. It is substantially lower in cost than other imaging modalities and does not use harmful ionizing radiation. Drawbacks include various limits on its field of view, such as the need for patient cooperation, dependence on physique, difficulty imaging structures behind bone and air, and the necessity of a skilled operator, usually a trained professional.



Blood Test

A **blood test** is a laboratory analysis performed on a blood sample that is usually extracted from a vein in the arm using a hypodermic needle, or via fingerprick. Multiple tests for specific blood components, such as a glucose test or a cholesterol test, are often grouped together into one test panel called a **blood panel** or **blood work**. Blood tests are often used in health care to determine physiological and biochemical states, such as disease, mineral content, pharmaceutical drug effectiveness, and organ function. Typical clinical blood panels include a basic metabolic panel or a complete blood count. Blood tests are also used in drug tests to detect drug abuse. In some of the United States, a blood test is required before marriage.

Laboratory diagnostic machines are automated devices that perform chemical and biological tests. They are used in *hospital* laboratories to measure the chemical properties (and other characteristics) of patient samples such as blood, tissue, *DNA* or urine. The machine's analysis tells doctors if a patient has a certain disease or condition.

Laboratory diagnostic machine

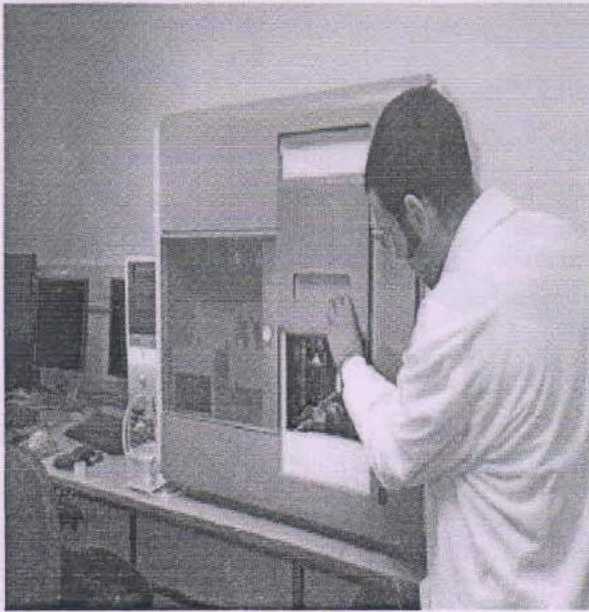

Diagnostic tests were carried out by hand by hospital laboratory technicians until the 1950s. They were slow, expensive and mistakes occurred. Automated machines revolutionised laboratory diagnosis. One of the first was the AutoAnalyzer, invented by *Leonard Skeggs* in 1951. He wanted a faster way to manage blood testing within his hospital laboratory, so he built a mechanical device able to perform one blood test per minute. The 'Robot Chemist' was invented by Hans Baruch in the 1950s. This machine also automated blood analysis, and was the first laboratory machine to give a digital print-out of results.

More automated laboratory machines were developed from the 1960s. Developments in *computers* and *robotics* meant machines became more sophisticated. The sequential multiple analyser with computer could accurately process 20 tests every 24 seconds. Fast and accurate sample analysis made laboratory diagnosis more useful, and by the end of the 20th century machines had made the hospital laboratory crucial to medical practice.

ABHINESH JAYRAM M.

GOUTHAM.

Signature of the Student

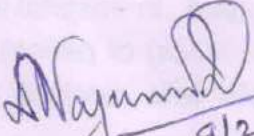
9/2/19
Course Teacher

HoD / EIE
9/2/19



DEPARTMENT OF ELECTRONICS AND INSTRUMENTATION ENGINEERING

NAME LIST - BTECH 2017-2021 BATCH

Attendance- Industrial Visit 2nd Feb 2019

S.no	RRN	Name	Signature
-1	170061601001	ABINESH JAYARAM MURUGANANDAM	<i>[Signature]</i>
-2	170061601002	ABOOBAKAR SIDQUE. S	<i>[Signature]</i>
-3	170061601003	AFSAL. S	<i>[Signature]</i>
-4	170061601004	ANAND. M	<i>[Signature]</i>
-5	170061601005	AZARUDEEN. R	<i>[Signature]</i>
-6	170061601006	DENNIS DANIEL. I	<i>[Signature]</i>
-7	170061601007	DHANVEER ASLAM. A	<i>[Signature]</i>
-8	170061601008	GOUTHAM. S	<i>[Signature]</i>
-9	170061601009	IRFAN. S	<i>[Signature]</i>
-10	170061601010	MOHAMMED FAYAZUDEEN. A. B	ABSENT
-11	170061601011	MOHAMED HASIM. S	<i>[Signature]</i>
-12	170061601012	MOHAMED IBRAHIM ALI. Z	ABSENT
-13	170061601013	MOHAMED ISMAIL SAMEER. H	<i>[Signature]</i>
-14	170061601014	MOHAMED MOHSIN. U. I	<i>[Signature]</i>
-15	170061601015	MOHAMED THAWFIQ. S	<i>[Signature]</i>
-16	170061601016	MOHAMED ASITH. N	<i>[Signature]</i>
-17	170061601017	MOHAMED RAIYAN. V. A	<i>[Signature]</i>
-18	170061601019	MOHAMED USMAN. J	<i>[Signature]</i>
-19	170061601020	NAWFAL HUSSAIN. J	<i>[Signature]</i>
-20	170061601021	RAMYA S. A	<i>[Signature]</i>
-21	170061601022	SAI ABIRAMI. K	<i>[Signature]</i>
-22	170061601023	SHAKIL AKTHAR. A	ABSENT
-23	170061601024	YAASIR AHAMED. M. S	<i>[Signature]</i>
-24	170061601025	LOYD VERGIL	ABSENT
-25	170061601026	SYED RISWAN	<i>[Signature]</i>
-26	170061601028	MOHAMED LAEEQ. R	<i>[Signature]</i>
-27	170061603001	M.KADHIRAVAN	<i>[Signature]</i>

Staff accompanied

D. Nagaraj : *[Signature]*
2/2/19

M.S. Muthukrishnan : *[Signature]*
2/2/19



B.S. Abdur Rahman
Crescent

Institute of Science & Technology

Deemed to be University u/s 3 of the UGC Act, 1956

ACCREDITED WITH "A" GRADE BY NAAC

DEPARTMENT OF ELECTRONICS AND INSTRUMENTATION ENGINEERING

Lr. No.: 02 /2019/ BSACIST/EIE/Industrial Visit

Date: 25-1-2019.

To
Hameed Hospital
46/ B-10, Thirumanjana Gopura Street
Manalurpettai Road
Thiruvannamalai -606601

Sir,

Sub: Permission for Visit to Hameed Hospital – Reg.

We are arranging field trips for our Second year students of Electronics & Instrumentation Engineering branch to familiarize with practical aspects. In this connection a visit to Hameed Hospital would be of immense benefit and relevance to them.

The details are given below:

No. of Students : 26

No. of Staff : 2

Date : 2nd-Feb.2019 or 9th Feb., 2019
(Any one day as per your Convenience)

We request you to kindly give them necessary permission for the visit as per your convenience.

Thanking you,

Yours Sincerely

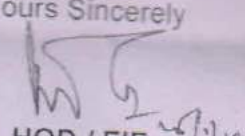
HOD / EIE

email : registrar@bsauniv.ac.in
www.bsauniv.ac.in

DESPATCHED

ON: 28/1/19

28/1/19

INDUSTRIAL VISIT

EIE STUDENTS

DATE:1/11/2018 (THURSDAY)

The II year EIE students were undergone an Industrial visit to J&J LEATHER ENTERPRISES, Nallambakkam Village, Chennai on 1.11.2018. started from BSACIST by 11am and reached the industry by 11.30am. After the formal security check, students were offered snacks and tea. Since this is the first visit for the students, they were very much excited by seeing industrial environment and all the machineries.

J & J Leather Enterprises Limited is a Private sector company incorporated on 29 May 1991. It is classified as Non-Govt company and is registered under Registrar of Companies, Chennai. Its authorized share capital is Rs. 30,000,000 and its paid up capital is Rs. 20,750,000. J&J Leather involves in Dressing and dyeing of fur. Manufacture of articles of fur. The main byproduct of J&J Leather is garments and belt.

Visit started from the raw material section, there all the unprocessed cleaned sheep leather which are imported from Iran, Iraq and middle east is stored.

While entering into the production unit where the raw material of leather called "WET BLUE" which is taken from the skin of sheep and goat is gathered for the process. This wet blue is added with some chemical for the removal of hair and flesh. After the removal of the hair and flesh, this by product is taken to a large drum where they will maintain a particular PH and they will add some chemicals and dye to make the product as colored and they will fix the thickness of the material by adding some sorts of other chemicals to that drum. This drum will rotate up to 14 to 16 hours per day and it is monitored from outside.

After the mixing the color and fixing the thickness, the material is then sent for the removal of excess water to a machine which has helical rotating blades, this will remove 50% of the excess water from the leather material.

After the removal of excess water this material undergoes some process called ironing and spraying. The material undergoes vacuum ironing (based on the material). Before ironing, the folded ends are corrected.

After the ironing process, spray process is being carried out in order to maintain the uniform texture. In this process the spraying machine has light detecting sensor where the light is passed on the leather material and where there is no leather the machine stops spraying. After this again ironing is carried out in order to make it soft.

At last these materials have kept for dry. For this they have set the conveyor assembly which holds the leather with clips. This entire set up is arranged in the roof. The main intention of this arrangement is, the heat released by all the machineries can be absorbed by the wet leathers, so that the internal room temperature is maintained. Also no additional space is required for drying. finally the dry leather is measured and its ready for dispatch.

Next to the production unit they have a Effluent Treatment Plant. 90% of the water is treated and reused and only 10% is collected as wastage. This waste is also properly collected and it is handed over to TNPCB (Tamilnadu Pollution Control Board).

With this, students learnt the entire process and the sequence of operation in leather processing. And also the scope of electronics and instrumentation engineers in that industry.

Electronics and instrumentation engineers can work in the maintenance dept, there all the measurements and monitoring can be taken care by the instrument engineers.

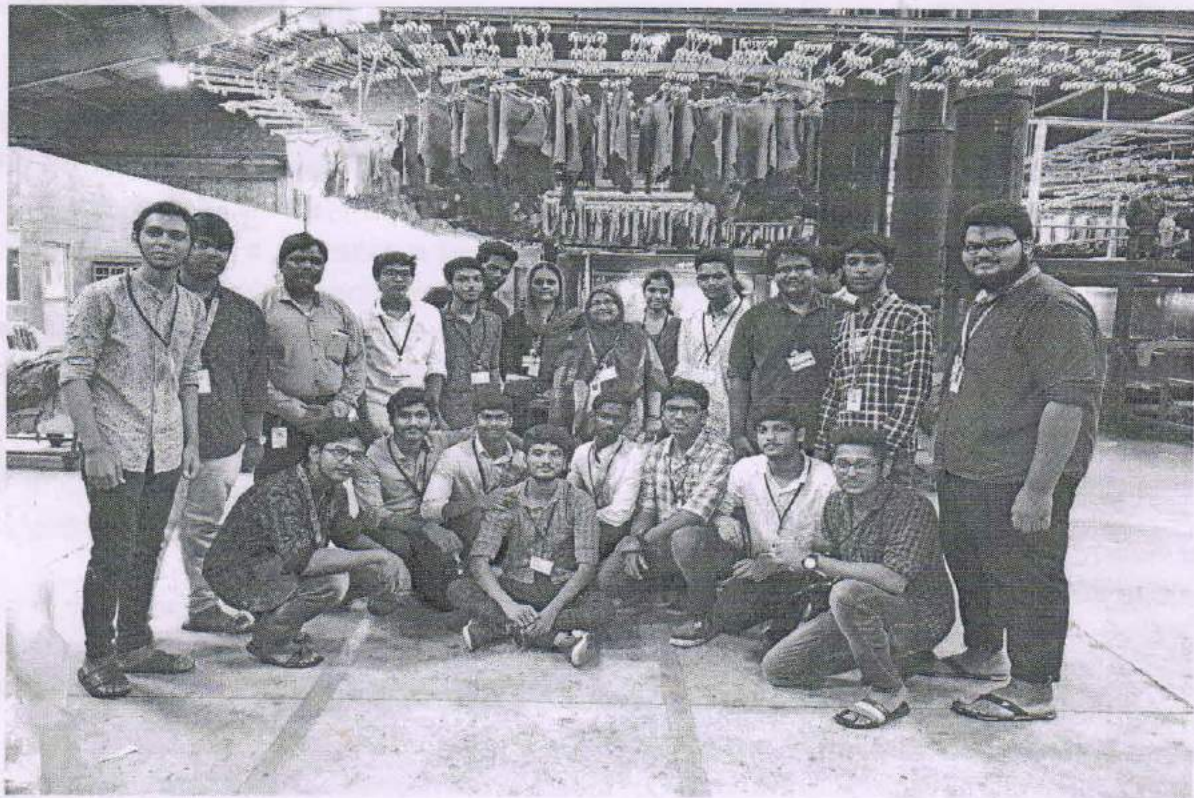



II year EIE students told that, they all had a great time and acquired knowledge from this visit. They expressed their thanks to our Management, Vice Chancellor, Registrar and Hod, and they also express their special thanks to Dr.D.Najumnissa Jamal, Prof/EIE for all the arrangements regarding this visit with in the short span of time and our class advisor Mrs. M.S.Murshitha Shajahan for accompanying with us.

Students expect more industrial visits in the forthcoming semesters.

M.S. Murshitha Shajahan
Class Advisor

M.S. Murshitha Shajahan
HOD/EIE
2/10/18



B.S. Abdur Rahman
Crescent
Institute of Science & Technology
Deemed to be University u/s 3 of the UGC Act, 1956
ACCREDITED WITH "A" GRADE BY NAAC

DEPARTMENT OF ELECTRONICS AND INSTRUMENTATION ENGINEERING

Lr. No. 10/2018 /BSARCIST/EIE/Industrial Visit

Date: 25-10-2018.

To
J. J. Leather Enterprises
Bhartiya fashion
Bhartiya International Ltd.,
342, Nallambakkam Village
Chennai-48

Sir,

Sub: Permission for Visit to J. J. Leather Enterprises – Reg.

We are arranging field trips for our II Year students of Electronics & Instrumentation Engineering branch to familiarize with practical aspects. In this connection a visit to J. J. Leather Enterprises would be of immense benefit and relevance to them.

The details are given below:

No. of Students : 27
No. of Staff : 2
Date : 31.10.2018

We request you to kindly give them necessary permission for the visit as per your convenience.

Thanking you,

Department of Electronics & Instrumentation Engg.
B.S. Abdur Rahman
Crescent
Institute of Science & Technology
Vandalur, Chennai-600 048.

Yours Sincerely

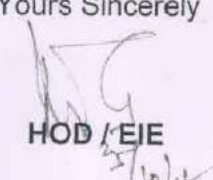
HOD / EIE

Appointment letter from the company:

Lotus Shipping Company

Custom House Agent R-364 / 2016 - CBS
New # 108, (Old # 279) Thambu Chetty Street, Chennai - 600 001.
Tel : 044-25251997 / 25251998 / 43558220, 43370011
E-mail : lotusshippingcompany@gmail.com



Date: 11/04/19

To whomsoever it may concern

We would like to inform you that based on your request letter ref/MBA/work report/2017/2019 dated 20.03.19. Mr. Abdul fasith S has been with us since 27.03.19 and his closing date will be intimated to you upon his completion of his work report.

Yours sincerely

LOTUS SHIPPING COMPANY

Managing Partner

S. Umasankara narayanan



Scanned with CamScanner

EASY AND SAFE LOGISTICS PRIVATE LIMITED

PERFECT SOLUTIONS FOR YOUR LOGISTICS

Management,
Management studies,
Advanced Institute of science & Technology,

Project Reg.

In your letter on the above subject, we are pleased to permit Mr. Abdul Hameed
to undertake his project in our company.

EASY AND SAFE LOGISTICS PVT LTD.

Authorised Signatory

COMPANY PROFILE



The company deals in all kind of Fresh vegetables and see foods. It offers products from all over the India, which helps in delivering various Fresh vegetables and Value-added Seafood and Fish varieties, from all locations across India to meet the growing Worldwide demand.

- Produce Professionals Source Quality Sea foods & Vegetables
- Our Sales Team Provides Options, Solutions, & Competitive Pricing
- Representing Growers and Packers to Maximize Opportunity
- Our Food Experts Source Quality Products for Retail or Foodservice
- Dairy-Deli Chill Specialists Manage Short Shelf Life Products
- Logistics & Regulatory Compliance for All Export Destinations
- Natural, Organic, Specialty Foods
- International Brand Representation and Private Label Development

What we do:

The company deals in all kind of Fresh vegetables and sea foods. It offers products from all over the India, which helps in delivering various Fresh vegetables and Value-

- The appointment is subject to satisfactory professional reference checks.
- The offer from Infiniti is valid for 30 days only from the date of offer, any extension in validity shall be at the discretion of the company and shall be communicated to you in writing.

Please forward to you joining us. Please do not hesitate to call us for any information you may need. Once you sign the duplicate of this offer as your acceptance and forward the same to us.

For Infiniti Software Solutions Private Limited



Manabhan
Managing Director

I accept the offer on the terms and conditions and shall report to work on



Date: 11/5/19

CERTIFICATE

We hereby certify that **Mr. Ahamed Shehabudeen. S**

Reg. No. 17225611007), Final year MBA Student of **B.S. Abdur Rahman Crescent**
Institute of Science & Technology, Chennai had undergone internship in our organization
 from **27th March 2019 to 18th May 2019.**

His **dedication and interest in learning** in learning various aspects connected with his study were
commendable. We wish him all success in future

SIL VEERAJAN

(Handwritten Signature)



18.05.2018

Assistant Manager (ops)
 TUTICORIN

Signature of Assistant Manager (ops)
 TUTICORIN

Date

MSA
SHIPPING
LINE

- | | | | | | | |
|---|---|---|--|---|--|---|
| CHENNAI :
Office No. 10/11/12, 3 rd Floor Kesar Arcade,
Rajiv Gandhi Centre, N. Santhoshan
Chennai - 600 001
Tel : +91 44 2333 297189 | COIMBATORE :
243, First Floor,
Anjalankodu Extension Main Road,
opp to Vasanth Mills,
Singanailur, Coimbatore - 641 005.
Ph : +91 0422 452025 | TIRUPUR :
No. 1, Second Floor,
A.R.P. Complex, 2nd Street,
Ashar Nagar (Near SAP Theatre),
Tirupur - 641 603.
Tel : +91 421 4331025 | COCHIN :
52/97D, First Floor,
Mallammal Junction,
Korhuvilly Road, Thevara,
Cochin - 682 013 -
Ph: +91 484 4054775 | DELHI :
L-4, 2nd Floor,
Opp. Nehru Apartments Gate,
No. 2, C.R. Park,
New Delhi - 110 019
Tel : +91 11 41078652 | KRISHNAPATNAM :
House No.9, Sai Nagar
(Opp to MRO Office)
Muthukur,
Andhra Pradesh.
Tel : +91 9585321827 | VISAKHAPATNAM :
SF-1, Visakha Business Centre,
D.No : 46-19-54, Mandavari Street,
Dondaparthy, Near Big Bazaar,
Visakhapatnam - 530 016
Phone : +91 891 6660925 |
|---|---|---|--|---|--|---|

Overseas Office : Colombo, Sri Lanka Port Klang, Malaysia

GLOBAL LOGISTICS

11.04.2019

Head of the Department,
Lawson Institute of Science & Technology
Chennai.

Re: ~~Request~~ certificate for doing internship

Sub: Permission for Internship- Reg.

In reference to your letter regarding the Internship request from your college, we are pleased to permit Mr. A. Anwar pursuing MBA to undertake with our organisation from 18.03.2019 to 15.04.2019. Timing morning 9.30 am to 4.30 pm.

For GLOBAL LOGISTICS SOLUTION INDIA PVT. LTD.



Global Logistics Solutions (India) Pvt. Ltd.

Leelavathi Building, 5th Floor, 69, Armenian Street, Chennai-1, India.

Tel : (91) 44 4500 2401 Fax : (91) 44 4500 2402 E-mail : info@globallogistics.co.in

www.globallogistics.co.in



IOS

TO WHOMSOEVER IT MAY CONCERN

21/05/2019

RAHMAN CRESCENT
INSTITUTE OF SCIENCE & TECHNOLOGY
Chennai-600 048

to confirm the Internship completion of **Ms.V.ASWINI (Reg No:170292601010)**, of MBA
at **Rahman Crescent Institute Of Science & Technology, Chennai - 600 048** on

was involved in understanding the **Concepts of Digital Marketing and Digital Sales.**

Wishing **ASWINI** a bright future.

For Nettyfish Networks Pvt Ltd,

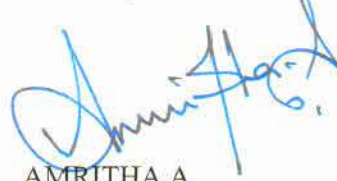

AMRITHA.A

HEAD HR

NETTYFISH
No. 85, Padmini Complex
Northern Wing 2nd Floor,
1st Main Road, Gandhi Nagar,
Adyar, Chennai-600 020.



Monday, May 19th, 2019

TO WHOM SO EVER IT MAY CONCERN

We are glad to inform you that **Mr. Deepak Kumar** from B.S. Abdul Rahman Crescent Institute of Science and Technology, Chennai, has successfully completed his project intern from 22nd March, 2019 - 19th May, 2019.

During his project intern, he was exposed to the various department activities in our Company.

We found him extremely inquisitive and hard working. He was very much interested to learn the function of our organization and also willing to put his best efforts and get in to depth of the subject to understand it better.

His associations with us were very fruitful and wish him all the best in his future endeavors.

For Blue Axis shipping & freight LLC.

Azi F. Demuguchi

Authorized Signature





B.S. Abdur Rahman
Crescent
Institute of Science & Technology
Deemed to be University u/s 3 of the UGC Act, 1956
GST Road, Vandalur, Chennai 600 048

A STUDY ON SALES PROMOTION AND ADVERTISEMENT

A PROJECT REPORT

on



Submitted by

G.GOKULAKRISHNAN

RRN: 170292601013

Under the guidance of

Mrs. J.HEMALATHA

in partial fulfillment for the award of the degree of

MASTER OF BUSINESS ADMINISTRATION

May 2019



B.S. Abdur Rahman
Crescent
Institute of Science & Technology
Deemed to be University u/s 3 of the UGC Act, 1956
GST Road, Vandalur, Chennai 600 048

A STUDY ON SALES PROMOTION AND ADVERTISMENT

A PROJECT REPORT

on



Submitted by

G.GOKULAKRISHNAN

RRN: 170292601013

Under the guidance of

Mrs. J.HEMALATHA

in partial fulfillment for the award of the degree of

MASTER OF BUSINESS ADMINISTRATION

May 2019



www.innova.com

Internship Letter

28 March 2019

Mr. [Name]
[Address]
[City, State, Zip]

We congratulate you on being selected for internship with Innova Solutions Private Limited. Your training is scheduled to start effective from **25 March 2019**.

Your internship will include training/orientation and focus primarily on learning and development.

Role: BGC Process - Human Resources

Stipend: INR 10,000 per month

We look forward to working with you!

Innova Solutions Pvt. Ltd.

Head of HR - Human Resources

INNOVA SOLUTIONS PRIVATE LIMITED
[Address]
[City, State, Zip]
[Phone Number]



Industry and company Curriculum

COMPANY PROFILE

Kerzner International Limited

Kerzner International Holdings Limited, through its subsidiaries, is a leading developer and operator of destination resorts, ultra-luxury hotels and innovative entertainment and gaming experiences. Kerzner's flagship resort includes Atlantis, The Palm, Dubai, a 1,500-room, water-themed resort on the Palm, overlooking the Arabian Sea and mainland Dubai and Atlantis, The Royal in China, and in development. The Royal Atlantis Resort & Residences in Dubai and Atlantis Ko Olina in the United States. Under the One&Only brand, Kerzner manages some of the most top-rated ultra-luxury resorts in the world, located in Mexico, Mauritius, the Maldives, South Africa, Dubai and Australia. Additionally, the One&Only Mazagan & Golf Resort, a 500-room destination golf and casino resort in Morocco, is also operated by Kerzner International. For more information on Kerzner International, please visit kerzner.com.



KERZNER international



ATLANTIS



One&Only



MAZAGAN

Industry and company Curriculum

COMPANY PROFILE

Kerzner International Limited

Kerzner International Holdings Limited, through its subsidiaries, is a leading developer and operator of destination resorts, ultra-luxury hotels and innovative entertainment and gaming experiences. Kerzner's flagship resort includes Atlantis, The Palm, Dubai, a 1,500-room, water-themed resort on The Palm, overlooking the Arabian Sea and mainland Dubai and Atlantis, The Royal in China, and in development, The Royal Atlantis Resort & Residences in Dubai and Atlantis Koi Olina in the United States. Under the One&Only brand, Kerzner manages some of the most top-rated ultra-luxury resorts, located in Mexico, Mauritius, the Maldives, South Africa, Dubai and Australia. Additionally, The Palm Jumeirah Golf Resort, a 500-room destination golf and casino resort in Morocco, is also operated by Kerzner International. For more information on Kerzner International, please visit kerzner.com



KERZNER international



ATLANTIS



One&Only



MAZAGAN



Tube Products of India

(A Unit of Tube Investments of India Ltd.
Formerly Known as TI Financial Holdings Limited)
Post Box No. 4 & 18, CTH Road, Avadi,
Chennai 600 054, India.
Tel: 91.44.42291999
Fax: 91.44.42201990/42291991/42291992
Website : www.tubeproductsindia.com
GST IN : 33AADCT1398NTZX
CIN : L35100TN2008PLC069496

17-05-2019

CERTIFICATE

This is to certify that **Mr.JAYAKUMAR Y (Reg.No.170292601017)**, second year MBA student of Crescent Institute of Science & Technology, Chennai – 600 048, has successfully completed his Project under the title of "A study on Export Performance of TPI in our Organisation from 25th March 2019 to 16th May 2019.

We wish him all the best in his future endeavours.

For TUBE PRODUCTS OF INDIA

JOSEPH PREMRAJ
ASSOCIATE VICE PRESIDENT - HR



Regd. Office: Dare House
234 N/S C. Bose Road,
Chennai 600 001.
Tel: 91.44.42177770 -76
Fax: 91.44.42110404



4th April 2019

Offer Letter

Karthik Raja L

I am pleased to offer you a position with Protean as "PSR". Your services shall also be utilized for any of our client as Outsourced Employee whenever required at locations designated from time to time.

You shall use your best energies and abilities on a full-time basis to perform, at locations designated by the Company and including customer offices, the employment duties assigned to you from time to time. You shall also comply with all rules, regulations and procedures of the Company. Your performance will be reviewed at the end of your twelve months of employment and annually thereafter.

Remuneration and Benefits: You will be compensated with a Monthly CTC of Rs 11,720.00 (Eleven Thousand Seven Hundred and Twenty Only). Any tax and statutory liability shall be borne from the above Salary. Break-up of your Salary is enclosed.

You shall not leave the Company or leave the Company without giving at least thirty (30) days notice to the Company. The Company may terminate your appointment by giving thirty (30) days notice or less in lieu thereof.

Confidentiality: You shall abide by a strict policy of non-disclosure to any proprietary information made available to the Company or its Clients in the course of assignment.

You shall be liable to be transferred to any of the establishment / client site of the Company in India. On such transfer you will be governed by the rules and regulations operating in the establishment to which you are transferred.

You shall be on probation for three months. If your performance is not satisfactory you will be not able to continue.

You are requested to produce copies of your educational certificates & testimonials at the time of joining, otherwise this offer would stand cancelled.

We are confident that you will have an interesting and rewarding Career with us. You shall report for duty at **Water Works Pvt Ltd, Chennai, (Our Client Establishment) on 6th April 2019** looking forward to a prosperous relationship.

Protean Staffing Pvt. Ltd.



Accepted

Protean Staffing Private Limited

(formerly Protean Management Consultancy Pvt. Ltd.)

No.766, Block-2, Sakthi Towers, 4th Floor, Anna Salai, Chennai-600 002.

Phone : 844 - 2854 5844, 4263 4079 E-mail: tnbd@protean.co.in Website: www.protean.co.in



aapke vaade,
sar aankhon par

10th May, 2019

To
The Department of Management studies,
C. V. Raman Crescent Institute of Science and Technology
Chennai, Chennai.

Dear Sir/Madam,

We hereby certify that Ms. KAVITHA SELVAKUMARAN (Emp. Code: 99007620) is working with us since 28-
March-18. Her current office address is:

Canara HSBC Oriental Bank of Commerce Life Insurance Co. Ltd.
16th Floor, Wescare Tower, Door No. 16 (16/1 and 16/2),
Chennai Road, Teyyanampet, Chennai - 600018 Tamil Nadu

This letter is being issued to her on her request to submit in her college.

Thanking you,

Yours faithfully,

For Canara HSBC Oriental Bank of Commerce Life Insurance Company Limited

Assistant Vice President - Human Resources

Restricted

Scanned with
CamScanner

Malavika,

ings from LTI...!!!

e-mail is with regards to your application for an internship opportunity with LTI.
ratulations! Your internship has been finalized with our organization starting
8th April, 2019. Further details of the internship are as follows:

Location	Chennai
Reporting Manager	Yasmeen Rahaman
Start date	8th April, 2019
Stipend Payable	Rs. 8000/- pm

POC	Name	Contact No.
Boarding Team		044
POC	Mr. Kannan Sethu	66062686
Reporting Manager	Ms. Yasmeen Rahaman	
HR Spoc	Mr. Dinesh Patnaik	044 66062608

Address of Chennai branch is as under:

en &Toubro Infotech Ltd,
4, DLF IT Park,
Campus,
pakkam,
Chennai - 600089

ing you all the best...!!

s & Regards,
Thomas
Associate
Recruitment, Internship & Springboard team





AEO

Compliant

2015 Certified



Port

Par - Excellence

चेन्नै पोर्ट ट्रस्ट

CHENNAI PORT TRUST

Fax : +91-44-25361228

Phone: +91-44-25312000

: +91-44-25362201

प्रशासनिक कार्यालय

ADMINISTRATIVE OFFICE

राजाजी सालै, चेन्नै- 600 001.

Rajaji Salai, Chennai-600 001.

Website : www.chennaiport.gov.in

सामान्य प्रशासन विभाग, चेन्नै - 600 001

CENTRE FOR HUMAN RESOURCES DEVELOPMENT

GENERAL ADMINISTRATION DEPARTMENT, CHENNAI

सं.वि.के/031/2019/जी ए

दिनांक: 20/05/2019

प्रमाणपत्र / CERTIFICATE

यह प्रमाणित किया जाता है कि श्री/सुश्री Selvan MOHAMED RASIK YUSUF.P. (170292601021), MBA student(s) of B.S.ABDUR RAHMAN CRESECNT INSTITUTE OF SICENCE & TECHNOLOGY, CHENNAI-600 048 ने दिनांक 08.04.2019 से 20.05.2019 तक इंटर्नशिप प्रशिक्षण प्राप्त "A STUDY ON DISTRIBUTION OF CARGO STORAGE AT CHENNAI PORT TRUST" किया है। इस अवधि के दौरान उनका/उनकी आचरण व चरित्र अच्छा रहा।

It is certificated that student(s) of Selvan MOHAMED RASIK YUSUF.P. (170292601021), MBA student(s) of B.S.ABDUR RAHMAN CRESECNT INSTITUTE OF SICENCE & TECHNOLOGY, CHENNAI-600 048 has done Internship/Project Work titled "A STUDY ON DISTRIBUTION OF CARGO STORAGE AT CHENNAI PORT TRUST" from 08.04.2019 from 20.05.2019 during this period his/her conduct and character was good.

21/21/2019

Secretary
Chennai Port Trust

R. SUNNY RAJ
Asst. Secretary GII
Chennai Port Trust
Chennai - 600 001.
Cell : 8444756400

JOINING LETTER

Received: Bhary Z H
bharyz24@gmail.com

Subject: Appointment for post of Project Associate

Name: Mohamed Bhary,

We are pleased to offer you, the position of **Project Associate Trainee** with Technoarete under following terms and conditions:

1. Commencement of employment

Your employment will be effective, as of 25/03/2019

2. Designation

Your designation will be Project Associate and you will report to Mr. Logaraja.

3. Salary

Monthly salary: 9000 and other benefits.

4. Place of posting

You will be posted at Chennai. You may however be required to work at any place wherever which the Company has, or may later acquire.

5. Hours of Work

The normal working days are Monday through Saturday. You will be required to work extra hours as necessary for the proper discharge of your duties to the Company. The normal working hours are from 10AM to 7PM and you are expected to work not less than 50 hours each week, and if necessary additional hours depending on your responsibilities.

6. Leave/Holidays

- 100% You are entitled to casual leave of 1 day.
- 100% You are entitled to 1 working days of paid sick leave.
- 100% The Company shall notify a list of declared holidays in the beginning of each year.

COMPANY PROFILE



Moonstar Lines private limited is a leading Indian based shipping company was incorporated in 2010 and located in Chennai. Our company follows certain guidelines to its customers to maintain a standard quality in the field and to grow our organisation to the next level.

Moonstar lines pvt ltd shares the same mission, vision and value statement of the Group. Incorporated in the year 2010 to represent the nvocc operation in India. With Head office in Chennai and having its own offices in Tuticorin, Mumbai, Colombo, Malaysia.

Moonstar lines pvt ltd span in the Indian sub-continent, Far East Asia and Middle East. Operations that have made Moonstar Lines Pvt Ltd., a familiar sight on the high seas and beyond, operating out of offices in more than 30 ports, related inland container depots and worldwide locations with over a 100 dedicated employees.

MISSION: In a constantly evolving economic and geopolitical context, we draw on our experience to identify with our customers the risks to which they are exposed. We choose and analyze with them the most relevant solutions, in order to improve their comparative advantages, increase their logistics flexibility and limit the risks that are inherent in international supply chains.

VISION: Our goal is to enable our customers to successfully compete in their business environment by offering reliable, innovative and cost-effective logistics services. Together with lines and terminals, we provide value-added End-to-End services.

OUR COMPANY SERVICES:

- NVOCC
- Global Freight Forwarding
- One-way interchange agent
- Total logistics
- Ship agency service
- Project cargo service
- Port agency service



Port
Par - Excellence
चेन्नै पोर्ट ट्रस्ट

CHENNAI PORT TRUST

Fax : +91-44-25361228
Phone : +91-44-25312000
 : +91-44-25362201

प्रशासनिक कार्यालय
ADMINISTRATIVE OFFICE
राजाजी सालै, चेन्नै- 600 001.
Rajaji Salai, Chennai-600 001.
Website : www.chennaiport.gov.in

सामान्य प्रशासन विभाग, चेन्नै - 600 001

**CENTRE FOR HUMAN RESOURCES DEVELOPMENT
GENERAL ADMINISTRATION DEPARTMENT, CHENNAI 1.**

आवधिक/031/2019/जी ए

दिनांक: 20/05/2019

प्रमाणपत्र / CERTIFICATE

यह प्रमाणित किया जाता है कि श्री/सुश्री Selvan P.M. MOHAMED WASIM (170292601026), MBA student(s) of B.S.ABDUR RAHMAN CRESECNT INSTITUTE OF SICENCE & TECHNOLOGY, CHENNAI-600 048 ने दिनांक 08.04.2019 से 20.05.2019 तक इंटर्नशिप प्रोजेक्ट "AN ANALYSIS ON DRY BULK CARGO COOPERATION IN CHENNAI PORT TRUST" किया है। इस अवधि के दौरान उनका/उनकी प्रदर्शन व चरित्र अच्छा रहा।

It is certificated that student(s) of Selvan P.M. MOHAMED WASIM (170292601026), MBA student(s) of B.S.ABDUR RAHMAN CRESECNT INSTITUTE OF SICENCE & TECHNOLOGY, CHENNAI-600 048 has done Internship/Project Work titled "AN ANALYSIS ON DRY BULK CARGO - COOPERATION IN CHENNAI PORT TRUST" from 08.04.2019 from 20.05.2019 during this period his/her conduct and character was good.

Secretary
Chennai Port Trust

21/21/2019
R. SUNNY RAJ
Asst. Secretary G11
Chennai Port Trust
Chennai - 600 001.

COMPANY PROFILE



Moonstar Lines private limited is a leading Indian based shipping company was incorporated in 2010 and located in chennai. Our company follows certain guidelines to its customers to maintain a standard quality in the field and to grow our organisation to the next level.

Moonstar lines pvt ltd shares the same mission, vision and value statement of the group. Incorporated in the year 2010 to represent the nvocc operation in India. With Head Office in chennai and having its own offices in tuticorin, mumbai, Colombo, Malaysia.

Moonstar lines pvt ltd span in the indian sub-continent , far east Asia and middle east, operations that have made moonstar lines Pvt ltd., a familiar sight on the high seas and around the world, operating out of offices in more than 30 ports, related inland container depots and worldwide locations with over a 100 dedicated employees.

MISSION:

In a constantly evolving economic and geopolitical context, we draw on our experience to identify with our customers the risks to which they are exposed. We chose and advise with them the most relevant solutions, in order to improve their comparative advantages, increase their logistics flexibility and limit the risks that are inherent in international supply chains.

VISION:

Our goal is to enable our customers to successfully compete in their business environment by offering reliable, innovative and cost effective logistics services. Together with lines and terminals, we provide value-added End-to-End services.

OUR COMPANY SERVICES :

- > NVOCC
- > Global Freight Forwarding

SRI RAGHAVENDRA SHIPPING COMPANY PVT. LTD.

(An AEO Certified Organisation)

Customs, Shipping, Clearing, Transport, Container Handling & Forwarding Agents

"Sai Kirpa Building" 1st Floor, No.326/170, Thambu Chetty Street, Chennai - 600 001. INDIA

Ph : 044 2535 2031, 2535 4232 Fax : 044 2535 8607 E-mail : admin@srsco.co.in

Web : www.sriraghavendrashipping.com GSTIN : 33AAACS7025E1ZS PAN : AAACS7025E

TO WHOM IT MAY CONCERNDate: 20th may 2019

Respected sir/Madam

This is to certify that Mr. A.MOHAMMED ISMAIL. No: 170292601029 MBA Final year student of B.S.A. Crescent institute of science and technology has been successfully completed his project on "A STUDY ON MATERIAL HANDLING & STORAGE PACKAGING" in our company.

Training period from 18th march 2018 to 20th May 2018.

During his training period he showed keen interest in the project assigned to him.

We wish him all the best in his future endeavors.

Thanking you,

Yours faithfully,

For Sri Raghavendra Shipping Company Pvt. Ltd.

S. Radikeavan
S. RADIKEAVAN
MANAGING DIRECTOR



JOB OFFER LETTER



To,
SEBOUNKA
PLOT No: 119, Vimala nagar , 2nd main road,
Maddurahalli,
Chennai-600 100.

Dear SEBOUNKA,

Sub: Appointed as HR EXECUTIVE

With reference to your application for a suitable placement in our organization and the subsequent interview you had with us, we are pleased to offer you an appointment in Phoenix Systems Consultancy Services, as HR EXECUTIVE on the following terms and Conditions:

Date of Commencement of Employment:

Your employment will commence on 01.04.2019.

You would be a part of the Education Business Group and shall be reporting to the CEO or to any officer nominated by her. During your Service period, the Company reserves the right to transfer you to any other Department within the Company or Client on your willingness.

Probation and Remuneration:

You will be on probation for 3 months and your employment with the company will be confirmed based on your performance. During your probation period, you need to handover any copy of your academic certificates to the company and the same will be returned to you on your relieving from the company.

You shall be paid a Monthly gross Salary of Rs.10000. This shall be paid on the 7th of the subsequent Month, or on the preceding working day, whichever is earlier.

It is agreed that it shall be open to the company from to time to vary any remuneration, benefit, facility, or perquisite that may be extended to you on a review of the company's decision on this behalf.

Acceptance of Appointment Letter:

You shall intimate your acceptance of this letter within today, failing which the letter of appointment will be withdrawn and cancelled automatically without any further communication in this regard.



23-05-2019

To Whomsoever It May Concern

This letter intends to confirm that Mr.Muthaiah S (EMP code: PUF0007) is an employee of this organization. He has joined this company from 01st April 2019 as Trainee in Sales and Marketing.

This certificate is being issued for the purpose of his graduation during viva voce.

Any queries in this regard will be entertained on request.

Yours Sincerely
Palaniunna Foods (Pvt) Ltd

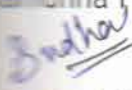
Authorised Signatory

CERTIFICATE OF INTERNSHIP

MAY 20, 2019

TO WHOMSOEVER IT MAY CONCERN

This is to certify that NAFIS AHAMED S has successfully completed his Internship Programme as a 'Trainee (Export Documentation)' with **CONSOL EXPRESS PRIVATE LIMITED, CHENNAI** from 25th March, 2019 to 20th May, 2019.

He efficiently contributed to the work and was found to be hard-working, keen to learn & ready to accept responsibilities.

We wish him all the best in future endeavours.

For
CONSOL EXPRESS PRIVATE LIMITED

(Signature)
CONSOL EXPRESS PRIVATE LIMITED.

(Signature)
MILAJH Authorised Signatory
CEO

At One Point All Services

[CIN NO: U74999TN2017PTC114249]

Consol Express Private Limited

REGISTRATION NO: 71/27, 1st floor | Johndravar Street | Kaladipet | Thiruvottiyur | Chennai | 600019 | India.

BRANCH OFFICE: Old # 125, New # G - 67 | 1st Avenue, Anna Nagar East | 2nd Floor | Chennai 600 102 | India.

Tel No. +91 44 - 42614966 | D : +91 44 -42115913



The Human Capital Development Co

Internship Offer Letter

29th March 2019,
Chennai.

To

NarsheenHinaz

MS Crescent Institute of Science and Technology, Vandalur

Dear NarsheenHinaz

In response to your application we would like to congratulate you on being selected for internship with InFI based at Chennai. Your training is scheduled to start effective from 29th March 2019 for a period of 3 months. All of us at InFI are excited that you will be joining our team!

We look forward to seeing you and offer a very warm welcome.

R. Sathya

R. Sathya

HR & Operations

INSTITUTE FOR INDUSTRY CAREERS PVT. LTD
100 Feet Road, 4th Floor, 45 Avenue,
Chennai 600 097
Tel: 044-2200 097

FINE GLOBAL LOGISTICS

401, 4th Floor, Panorama Complex, Navjivan Press Road,
Income Tax, Off Ashram Road, Ahmedabad-14,
Phone : +91-8672002772 M : +91-90990 74084
Email : sudhagar@finegloballogistics.com

PRIVATE & CONFIDENTIAL

April 02, 2019.

Milal Dharini V.

ID No. : 535

Dear Ms. Dharini,

We are pleased to make you an offer of appointment as Officer – Documentation & Customer Service in our organisation.

The details of your remuneration and benefits are given in Annexure. The following are the terms and conditions of the appointment.

Terms :

- You shall be required to join our office on or before 09th April, 2018.
- You will be on probation for a period of six months or such extended period as may be decided by the management based on your performance during the probation period.
- On satisfactory completion of your probation period, including that of extended period, if any, you will be confirmed in the services in our organisation in writing.

Other Terms and Conditions of service :

Professional Ethics & Confidentiality :

While you are in the services in our organisation, you are not permitted to carry on any business or profession or enter, for any part of your time, in any capacity, the services of, or be employed by or engaged with any other firm, company or person. You will devote your whole time and attention to your office work to promote the interest of the Bank. You will not divulge details like your compensation structure (CTC), performance rating, performance bonus amount, increment, etc. and will not divulge to any person or utilize any of the company secrets or other related information (which you may possess by reason of your association with the Bank) with any external agencies, press etc. outside the company. Any act in breach of this term would entail initiation of appropriate action as deemed fit by the company.

IT Security Practice & Procedures :

While you are in the services of the company, you will adhere to the IT security Practice & procedures as prescribed by our organisation. Any instance/s of violation or any attempted violation of the aforesaid IT Security Practices and Procedures on your part shall result in disciplinary action.

Touring :

You will have to travel as required by the Company time to time. In the event of the company sending you abroad for training, business conferences, you will have to execute an agreement and give an undertaking for serving the company for a minimum of period of one year.

Corporate Office : B-906, 9th Floor, Singature II, Near Sarkhej Sanand Circle, S.G. Highway, Ahmedabad-380021.
Tel : +91-79-40092294 / +91-90990 74084. Email : finegloballogistics@gmail.com

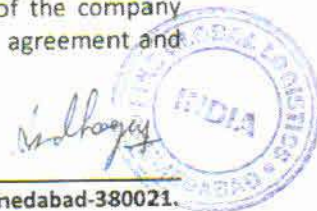

Forwarding (Air & Sea) * Transportation/Supply Chain * Custom Clearances * EXIM Consultancy

2.2 COMPANY PROFILE:

YONEX:

The company was originated in 1946 by Minoru Yoneyama as a creator of wooden floats for fishing nets. The company was advanced enforced out of this market for the reason that of the invention of plastic floats. This commanded to a commitment by Yoneyama to not ever another time be left behind by technological advancements.

In 1957, Yoneyama began to make badminton racquets for additional brands. By 1961, the first Yoneyama-branded racquet was declared, and in additional two years an export company was shaped for the worldwide supply. Then the company began to make aluminium badminton racquets in 1969, it is found that the same technology could be applied to the tennis racket which the company introduced in 1971. The company began to experiment it with graphite shafts for both varieties of rackets and found that these would also be advantageous for golf clubs.

In 1982 Yonex originated out with the new oversized tennis racquet in the REX-series with the R-7 and R-10 racquets. By that time Martina Navratilova played with the R-7 and was very effective. One year later, the innovative series Rexking was established with the R-22. Navratilova subsequently used the white RQ 180 widebody frame till the early 1990s.

Yonex has converted into the dominant corporate player in badminton. A lot of advanced players use YONEX as their racquets, as it is the preferred choice amongst professionals.



Fig.1.1 Yonex

SPORTS SUPPLIERS (MADRAS)

GST NO:33ADTF59036L1ZB

(House of Sports Goods and Fitness Equipments)

No.27, (old no.14), Wallajah Road, Chepauk, Chennai -600 005.

Email ID: ssmwallajah@gmail.com Ph no: 044-48557891, 28413200

10.4.2019

TO WHOM SOEVER IT MAY CONCERN

We hereby would like to inform you that we have permitted Mr Praveen Krishna who is doing his final year of MBA in Crecent College of Engineering to do his project work related to his studies at our office from 21st March to 20th May 2019.

Thanking you

Regards

Yours faithfully,

for Sports Suppliers (Madras)

Sanjay Jand

Partner

CCE

Customer Care Enterprises

we promise, we deliver

INTERNATIONAL COURIER & CARGO

31/1, 1st Floor, (Behind AXIS Bank

Double Road) Shanthi Road,

Shanthinagar, Bangalore - 560027

Mob: 76 7675 4456

www.customercareenterprises@gmail.com

TO,

Date : 21-03-2019

Head Of The Department,
WBA Department,
B.S.Abdur Rahman Crescent Institute of Science & Technology,
GST Road, Vandalur, Chennai-600048.
Tamil Nadu.

Respected Madam/Sir,

This letter is to confirm our offer of internship to Mr.P.PREMCHANDU (Reg.No.170292601036) of
WBA Department of B.S. Abdur Rahman Crescent Institute of Science & Technology, GST Road,
Vandalur, Chennai-600048. From 21-03-2019 to 24-05-2019.

He has joined as Logistics Co-Ordinator at our Company. He would handle our Outgoing Courier,
Co-Ordinate with Vehicles regarding Cargo Pickups and Segregation.

He would also create a daily based work report till the time he works for the Company.

The Company will provide a stipend of Rs.5000/- PM.

We wish Mr.P.PREMCHANDU a bright future in Customer Care Enterprises.



Customer Care Enterprises,



To,
Project Supervisor / HOD Deptt of Mngmt Studies
Crescent Institute of Science and Technology,
Wandakur, Chennai- 48

Subject - Internship offer

Dear Sir,

In reference to your letter with reference No. MBA/PROJ/2017-19, we are happy to offer your student **Mr. Pritam Mazumder (Reg No. 170292601037)** an internship project in the field of **Business Development** from 25th March 2019 for TWO months. We are sure that he will apply his knowledge gained out of this course and contribute towards this project and the organization. The project will be completed by 24th of May 2019

With best complements

Tanmay Bhowmik
Tanmay Bhowmik
25/3/19



Head of Strategy

Certum Ventures Pvt Ltd.

Bengaluru 560026

18.03.2019

Department of Management Studies,
SRM Institute of Science & Technology

Dear Project Acceptance Letter from SEAWAVES SHIPPING SERVICES,

Respected Sir,

Herewith the acceptance of the Project duration for two month for the student **Mr. Ramakrishnan,** Reg. ID: **(20292601038)**. We confirm the fullest support to undergo the project by way of teaching in terms of practical and theoretical way along with the interest of the student.

We wish him Good Luck to be the successful training period as well as we wish him to be our part of company during the project period.

Apart from the above we expect to maintain discipline and punctual regulations during the tenure period of project.

Yours Sincerely,

For SEAWAVES SHIPPING SERVICES

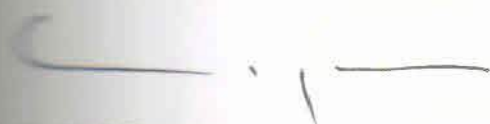

Authorized Signatory



APPOINTMENT LETTER

TO WHOMSOEVER IT MAY CONCERN

21/05/2019

Respected The Department,

DEPARTMENT,

B.S.ABDUR RAHMAN CRESCENT
INSTITUTE OF SCIENCE & TECHNOLOGY
Vandalur, Chennai-600 048.

Respected Madam/Sir,

I am pleased to confirm the Internship completion of **Ms.G.REVATHI (Reg No:170292601039)**, of
Department of B.S.Abdur Rahman Crescent Institute Of Science & Technology, Chennai - 600
on **30th May 2019**.

Her internship was involved in understanding the **Concepts of Digital Marketing and Digital Sales**.

I wish **Ms. G.REVATHI** a bright future.

For Nettyfish Networks Pvt Ltd,

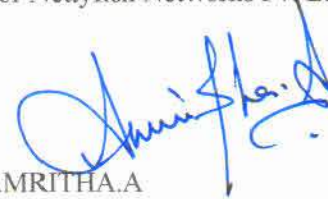

AMRITHA.A

HEAD HR

NETTYFISH
No. 85, Padmini Complex
Northern Wing 2nd Floor,
1st Main Road, Gandhi Nagar,
Adyar, Chennai-600 020.

Ms. Sr.

This mail is to certify that **Ms. Rishvika. D, MBA**, Student of B.S. Abdur Rahman Crescent Institute of Science & Technology is doing her internship in **HexaCorp's Business Development Department** from the period of **18th of March, 2019** and she will be continuing it till **31st of June, 2019**.

This will be a paid internship and she will be paid a stipend of **INR 5000/- per month**. An Internship certificate will be provided at the end of the internship tenure.

Regards,

Natheem . H – Human Resource

HexaCorp Technical Services Private Limited

Platinum Towers, No: 11, Old Trunk Road, Pallavaram, Chennai 600043

India: 044- 48517774 (W)

<https://www.linkedin.com/in/natheem-h-b0033a139/>



**Microsoft
Partner**

Collaboration and Content
Application Development

Certified MBE Company



Please consider the environment before printing this e-mail

DISCLAIMER : The content of this email and any attachments are confidential and intended for the named recipients only. It shall not attach any liability on the originator or HexaCorp or its affiliates. Any form of reproduction, dissemination, copying, disclosure, modification, distribution, and/or publication of this message without the prior written consent of the author is strictly prohibited. If you have received this email in error please delete it and notify.

Project No: ADCT1198G
Title: ADCT1198GSD001
ID: 15010TN2009PTC070705



18.03.2019

Department of Management Studies,
Sri Lanka Institute of Science & Technology

Re: Project Acceptance Letter from **TM CARGO SOLUTIONS PVT LTD,**

Respected Sir,

In view of the acceptance of the Project duration for two month for the student **Mr. K. Ruthra** (Matric. No: **170292601041**). We confirm the fullest support to undergo the project by way of providing in means of practical and theoretical way along with the interest of the student.

We wish him Good Luck to be the successful training period as well as we wish him to be our part of our company during the project period.

From the above we expect to maintain discipline and punctual regulations during the tenure of project.

Best Regards,

For **TM CARGO SOLUTIONS PVT LTD**

A handwritten signature in blue ink, consisting of several horizontal and vertical strokes, is written over a horizontal line.

Authorized Signatory



ABT Limited

India's Leading Company

March 25, 2019

As Trainee (Assistant) in our organization on the following terms and conditions:

: Parcel Service	
: Madras TR	
: Trainee (Assistant)	
: Consolidation	5500.00
HRA	2750.00
Washing	1100.00
Others	1078.00
Tea batta*	572.00
Total	11000.00

*Condition Apply

: The Chief Manager, ABT PS, MAS TR

: Will take effect from date of joining for period of 2 years
And it may be extend as per the clause No. 7(e)

Transfers to other departments /branches/sister concerns if found necessary for the purpose of acquiring skills /
other requirements.

You are bound to follow the company rules, policies/standing orders in force from time to time. You are liable for transfer from
any office/branches/ business interests. You shall not engage yourself in any other gainful
activity during the service.

Employment is not guaranteed by the company. The company does not guarantee employment on completion of training
and you are not bound to take up a job in the company as well.

The company reserves the right to terminate your service during the training period without notice and without assigning any
reason.

Your services will continue till your services are confirmed in writing. Your performance will be reviewed every six
months. If your performance is not satisfactory it will be extended /Terminated only at the discretion of Management.

The company reserves the right to recast the salary and other allowances at its discretion.

If the information provided to you at the time of this offer is found to be incorrect or not true you will be liable for termination of
employment.

On completion of one year from the date of joining, 1 month salary will be adjusted against the cost of training,
if any, provided. One month notice is must if you want to leave this organization under valid reason.

You are hereby informed that you are involved in criminal activities as of now or at a later stage then this appointment
will be cancelled.

Your services are subject to your medical fitness as certified by a registered Medical Practitioner or an authorized medical
officer. Your health will be checked periodically.

If you are absent without knowledge or permission of your superior or if you indulge in any act of misconduct your
employment will be terminated without any notice and in that case, you will not be eligible for salary.

To accept the above terms, please sign the duplicate copy as token of your acceptance and forward the same with two
recent photographs, certificate proof for age and qualifications. You may report for duty at ABT Parcel
Service, ABT Limited, Anna Institute of Technology Chembarambakkam (PO), Chennai 600 123. Within 7 days on receipt
of this offer, your candidature will be cancelled automatically.

ADDRESS : P.B. NO. 3790, 180, RACE COURSE ROAD, COIMBATORE - 641 018.
Grams: SANJEEVI Fax: 0422-4333100

CIN NO: U60231TZ1931PLCo0006

JOB OFFER LETTER



LIDER CONSULTANCY SERVICES PVT LTD

Plot No. 10, Sector 10,
Gurgaon - 122 002, Haryana

10-04-2019

Mr. **Shahid Ahmed A**

We are pleased to extend the following offer of employment to you on behalf of **LIDER CONSULTANCY SERVICES PVT. Ltd**, further to the interview and discussions you had with us. Your starting date will be **08 April 2019**

You are appointed to the position of **HR - Trainee** and in this capacity, you will report to the **Head of Operations**. As **HR - Trainee**, your starting Monthly Take Home will be **Rs. 7000/- (Seven Thousand Only)**. You will be on a probation period of three months.

We request to confirm our offer of employment in our Organization under the following terms and conditions.

TERMS AND CONDITIONS:

The offer will include for efficient, satisfactory and economical operation in the area of responsibility that may be assigned to you from time to time. As an employee of this company, you will maintain a high standard of loyalty, efficiency, integrity and will liaise with employees/workers in the organization.

The management will be within its rights to transfer you for work or loan your services to any other unit/division/department where the company has an office or branch or unit at present or may have at any time in future.

You will devote your whole time and attention to the interest of the company and will not engage yourself in any other work either paid or in honorary capacity.

The appointment is being made on the basis of your particulars such as qualification etc. declared by you in your application for employment and in case any information as furnished by you is found false or incorrect, your appointment will be deemed void ab initio and you will be liable for termination without any notice or salary in lieu thereof.

Notwithstanding as indicated in your application for appointment shall be deemed to be correct and sending any communication to you at the given address shall be deemed to be received upon you.



B.S. Abdur Rahman
Crescent

Institute of Science & Technology
Deemed to be University u/s 3 of the UGC Act, 1956
GST Road, Vandalur, Chennai 600 048

BONAFIDE CERTIFICATE

Certified that this project report is the bonafide work of **A STUDY ON CAUSAL RELATIONSHIP BETWEEN MUTUAL FUND AND STOCK MARKET PERFORMANCE** undertaken by **SHARADHA SHA VALLI (RRN: 170292601044)** who carried out the project work under my supervision. Certified further, that to the best of my knowledge the work reported herein does not form part of any other project report or dissertation on the basis of which a degree or certificate was conferred on an earlier occasion on this or any other candidate.

SIGNATURE

Dr. N. ANURADHA

SUPERVISOR

Associate Professor

Department of Management Studies

B.S. A Crescent Institute of

Science & Technology

Vandalur, Chennai – 600 048

SIGNATURE

S. CHARANYA

CREDIT MANAGER (FINANCE DPT)

CROWNE PLAZA HOTEL

132, TTK road , Alwarpet

Chennai – 600 018

SIGNATURE

Dr.M.SHANMUGAM (HOD)

Department of Management Studies

B.S. A Crescent Institute of Science & Technology

Vandalur, Chennai – 600 048

CROWNE PLAZA
CHENNAI-ADYAR PARK

No.132, T.T.K ROAD
CHENNAI - 600 018.

Appointment Letter

April 23,2019

Kumar V
raipudi amman Kovil Street,
kkam.
- 600048.

Sharan Kumar,

reference to the discussions that we had with you, we are pleased to offer you an appointment
Software Solutions as **Management Trainee**. Your initial place of posting will be

annual total compensation will be **Rs.2,87,815 (Rupees: Two Lakh Eighty Seven
and Eight Hundred & Fifteen Only)**. The break-up is presented in Annexure A.

appointment will be governed by the terms and conditions of employment presented in
Annexure B. You will also be governed by the rules and regulations in vogue and those that may
change from time to time. At the time of formally resigning from services, you shall have to serve
a notice period of 90 days. Your compensation is highly confidential and if the need arises, you
may discuss it only with your Manager.

We request you to join us on or before **May 15, 2019**. At the time of joining, please submit the
following documents:

- Photocopy of your passport, certificates and mark sheets in support of your educational qualifications.
- Relieving letter from all your previous employer and last drawn pay slip, if applicable.
- Four passport size color photographs.
- Form 16 issued by previous employer(s), if applicable.
- Photo Copy of Address & ID Proof

Photocopy of PAN Card.

This appointment is subject to satisfactory professional reference checks.

This offer from Infiniti is valid for 30 days only from the date of offer, any extension in validity shall be at the discretion of the company and shall be communicated to you in writing.

Please forward to you joining us. Please do not hesitate to call us for any information you may require. Also, sign the duplicate of this offer as your acceptance and forward the same to us.

Sincerely,

Infiniti Software Solutions Private Limited



Kapadmanabhan

Managing Director

I accept the offer on the terms and conditions and shall report to work on

Date:



TVS Logistics Services Limited

Karunai Kudil,
No. 226, Cathedral Road,
Chennai - 600 086.
www.tvslsl.com

21 May 2019

TO WHOMSOEVER IT MAY CONCERN

This is to certify that A. SHEIK ABDULLAH (170292601046), a student of MBA
March 2019 From B.S.ABDUR RAHMAN CRESCENT INSTITUTE OF SCIENCE &
TECHNOLOGY has completed 3 months of internship with TVS Logistics Services
Ltd. He has worked on the project "Customer Perception on Logistics Procedure
with special reference to TVS Logistics Services" from 18 Mar 2019 to 20 May 2019.

He has completed the project on given timelines and his performance was
satisfactory.

For TVS Logistics Services Ltd

ANANDHAN MAR PRABHU
HEAD - HUMAN RESOURCES



ISO 9001:2015

www.tuv.com
ID: 9105041121



15th April 2019

To
BS Abdur Rahman
Head of the Department
Department of Management Studies
Crescent Institute of Science and Technology ,
Chennai - 600048

Dear Sir /Madam,

With reference to your request letter dated 12th April 2019, we are pleased to inform that **Mr. M Sheik Mohamed Alsafa (Reg No.170292601047)** pursuing second year MBA is permitted to undergo his Internship in our organization.

The period of Internship will be from 18th March 2019 to 25th May 2019.

Nageswar Rao R
General Manager – HR

TVS Electronics Limited

"Anhant E-Park", No.117/1, 8th & 9th Floor, L.B.Road, Adyar, Chennai - 600 020. Tel. + 91-44-4200 5200.
Registered Office: Jayalakshmi Estate, New No.29, (Old No.8), Haddows Road, Chennai- 600 006.
Corporate Identity Number : L30007TN1995PLC032941
E-mail id : webmaster@tvs-e.in Website: www.tvs-e.in



The Human Capital Development Co

Internship Offer Letter

29th March 2019,
Chennai.

To:

Siramesan.S

MS Crescent Institute of Science and Technology, Vandalur

Dear Siramesan.S

In response to your application we would like to congratulate you on being selected for internship with InFI based at Chennai. Your training is scheduled to start effective from 29th March 2019 for a period of 3 months. All of us at InFI are excited that you will be joining our team!

We look forward to seeing you and offer a very warm welcome.

A handwritten signature in black ink, appearing to read 'R. Sathya', is written over a faint, illegible printed name.

R. Sathya

HR & Operations.

INSTITUTE FOR INDUSTRY CAREERS PVT LTD.,
Address: 220/4, New No. 48, Fourrts Avenue,
Semburthi Nagar, Okkyam Pet,
Chennai- 600 097.



ISO 9001:2015

www.tvse.com
ID: 17029261049



15th April 2019

To
BS Abdur Rahman
Head of the Department
Department of Management Studies
Crescent Institute of Science and Technology,
Chennai - 600048

Dear Sir /Madam,

With reference to your request letter dated 12th April 2019, we are pleased to inform that Ms. Sri Nikhitha Pratipatti (Reg No.17029261049) pursuing second year MBA is permitted to undergo her Internship in our organization.

The period of Internship will be from 18th March 2019 to 25th May 2019.

Nageswar Rao R
General Manager – HR

TVS Electronics Limited

Sumant E-Park*, No. 117/1, 8th & 9th Floor, L.B.Road, Adyar, Chennai - 600 020. Tel.: + 91-44-4200 5200

Registered Office: Jayalakshmi Estate, New No.29, (Old No.8), Haddows Road, Chennai- 600 006.

Corporate Identity Number : L30007TN1995PLC032941

E-mail id : webmaster@tvs-e.in Website: www.tvse.in

Chennai Publishing Services Pvt. Ltd.

Date: 22nd May, 2019

To whom it may concern

certify that **MS. Srimanisha S(Reg. No. 170292601050)**, who is studying in her final
BA from B.S. Abdur Rahman Crescent Institute of Science & Technology Chennai, has
internship Project with us for the period of 2 months commencing from 18th March 2019
2019 at Chennai Publishing Services Pvt. Ltd, Chennai Project topic: "A Study of
Recruitment And Selection Process".

During project she has interacted closely with different members of the Departments.

Wish all the very best for her future.



Kesava

M Kesavamoorthy

Manager – Human Resources.

Director



ABT Limited

India's Leading Company

March 25, 2019

you as Trainee (Assistant) in our organization on the following terms and conditions:

: Parcel Service	
: Madras TR	
: Trainee (Assistant)	
: Consolidation	5500.00
HRA	2750.00
Washing	1100.00
Others	1078.00
Tea batta*	572.00
Total	11000.00

*Condition Apply

: The Chief Manager, ABT PS, MAS TR

: Will take effect from date of joining for period of 2 years
And it may be extend as per the clause No. 7(e)

...of departments /branches/sister concerns if found necessary for the purpose of acquiring skills /
...at most requirements.

...by the company rules, policies/standing orders in force from time to time. You are liable for transfer from
...as offices/branches/ business interests. You shall not engage yourself in any other gainful
...during the service.

...the shift allotted by the company. The company does not guarantee employment on completion of training
...compulsorily to take up a job in the company as well.

...to right to terminate your service during the training period without notice and without assigning any

...will continue till your services are confirmed in writing. Your performance will be reviewed every six
...is not satisfactory it will be extended /Terminated only at the discretion of Management.

...its right to recast the salary and other allowances at its discretion.

...by you at the time of this offer is found to be incorrect or not true you will be liable for termination of

...to sign within one year from the date of joining, 1 month salary will be adjusted against the cost of training,
...if provided. One month notice is must if you want to leave this organization under valid reason.

...to know that you are involved in criminal activities as of now or at a later stage then this appointment
...cancelled.

...subject to your medical fitness as certified by a registered Medical Practitioner or an authorized medical
...of your health will be checked periodically.

...without knowledge or permission of your superior or if you indulge in any act of misconduct your
...immediately without any notice and in that case, you will not be eligible for salary.

...the above terms, please sign the duplicate copy as token of your acceptance and forward the same with two
...size photographs, certificate proof for age and qualifications. You may report. for duty at ABT Parcel
...Road, opp. Loyola Institute of technology Chembarambakkam (PO), Chennai 600 123. Within 7 days on receipt
...the order will be cancelled automatically.

REGISTERED OFFICE : P.B. NO. 3790, 180, RACE COURSE ROAD, COIMBATORE - 641 018.
Phone: 0422-4333666 Grams: SANJEEVI Fax: 0422-4333100

CIN NO: U60231TZ1931PLCo0006



Vignesh B
Chennai

15th Apr 2019

PERSONAL & CONFIDENTIAL

Dear Vignesh B,

We are pleased to extend you an offer to join OYO as, **Sales Associate Band 1A.**

The offer will memorialize the terms of your employment by OYO. Your employment is contingent on your ability to provide employment eligibility documentation as required by law. However, if considered expedient and necessary, we may conduct background checks on you on our own or through third party. You hereby consent to any such background checks and undertake to co-operate if so requested by us. We look forward to your joining and helping us grow the Company's business!

Your employment with the Company may be subject to successful pre and/or post-employment background check.

The terms of your employment are as follows:

Start Date: 15th Apr 2019 or earlier

PLACE OF WORK: Your assigned work location is **Chennai**. The Company may, after giving you reasonable notice, transfer or assign your services to any place of business of the Company that may presently be operating, or which may subsequently be acquired or established, in any part of India or abroad.

Leave and Working Hours: You will be entitled to leave as per company policy and will observe the working hours that may be applicable to your category of employees and location of posting.

Reimbursement Obligation: Any cash bonuses or other expenses paid prior to normal salary periods are recoverable from the Company for the first 90 days of employment should you terminate your employment without cause.

Confidentiality and Invention Assignment: Your employment is conditioned upon your execution of Confidentiality and Invention Assignment Agreements and agreement to abide by the terms and conditions of those agreements. Failure to abide by the terms of the Agreements may result in your dismissal, and you are subject to the terms even after the termination of your employment.

Transfer & Relocation: You will be liable to transfer in such capacity as the company may from time to time determine to any other location, department, establishment, factory or branch of the company or its affiliate, or to any subsidiary companies. In such case, you will be governed by the terms and conditions of service applicable to the new assignment.

Non-Compete: You agree that during the term of your employment and for further period of 6 calendar months after separation from the Company, for whatever reasons, you shall not carry on or engage in directly or indirectly any business which competes directly or indirectly with any or all the business pursued by the Company in any manner, whether in India or overseas, at the relevant point of time or proposed to be pursued by the Company in the future, in respect of which proposal you were aware of or likely to be aware of considering the nature of the business ("Restricted Business"), other than through the Company.

Non-solicitation of Customers: You agree that during the term of your employment and for a further period of 24 calendar months after separation from the Company, for whatever reasons, you shall not directly or

Oravel Stays Private Limited

Registered Office: Delhi Rectangle Regus, Level 4, Rectangle 1, Commercial Complex D-4, Saket, New Delhi -110017

Corporate Office: 5th floor, Spaze Palazzo, Southern Peripheral Road, Sec-69, Gurugram-122001

Phone: 01246252000 Email: talent.acquisition@ovorooms.com

CIN: U63090DL2012PTC231770



B.S. Abdur Rahman
Crescent

Institute of Science & Technology
Deemed to be University u/s 3 of the UGC Act, 1956
GST Road, Vandalur, Chennai 600 048

BONAFIDE CERTIFICATE

Certified that this project report **A STUDY ON THE CHALLENGES FACED BY FREIGHT FORWARDERS** is the Bonafide work of **M. YUVARAJ** (VRRDDHI: 170292601054) who carried out the project work under my supervision. Certified further that to the best of my knowledge the work reported herein does not form part of any other project report or dissertation on the basis of which a degree or award was conferred on an earlier occasion on this or any other candidate.

SIGNATURE

SARWAR ALAM NOOR ALAM

SUPERVISOR

Associate Professor

Department of Management Studies

B.S. Abdur Crescent Institute of

Science & Technology

Vandalur, Chennai – 600 048

SIGNATURE

Mr. SITARAMAN

JOINT SUPERVISOR

DIRECTOR

VRRDDHI FREIGHT PVT.LTD

2B & 11C, Ega trade center

poonamallee high road,

Kilpauk, Chennai – 600 010.

SIGNATURE 22/5/19
Head of the Department

Department of Management Studies

B.S. Abdur Crescent Institute of Science & Technology

Vandalur, Chennai – 600 048

20th May, 2019

TO WHOMSOEVER IT MAY CONCERN

Completion of final year MBA project

We wish to confirm that Mr. **ABDUL HAMEED AH** [Reg no: **ABHESN1055**]. Is pursuing final year MBA in B.S Abdur Rahman Crescent Institute of Science & Technology, Chennai has successfully completed the work as an under finance assistant in our concern from 15th march to 20th may 2019.

During the tenure with us, conduct & behavior was observed to be good and we wish him all the best for his success in the future endeavors.



ABDUL HAMEED AH
[MANAGING DIRECTOR]



Industrial Oil, Metal Working Fluids and Marine Lubes

Western Gounder Thottam, Sanganoor Road, Jayaprakash Nagar, Ganapathy, Coimbatore - 641 006.
Office - 97501 26262, 98404 77601. E-mail : jescoenergy@gmail.com



20th May 2019

TO WHOMSOEVER IT MAY CONCERN

It is to certify that Mr. **Adibahmed.A** has successfully completed his internship tenure of eight weeks with More Retail Limited. His internship tenure was from 26-March-2019 to 03-May-2019. He was working with Human Resource Department and was actively & responsibly involved in the projects and tasks assigned to him.

Wishing him all success in his future endeavors.

More Retail Ltd

Mumbai - Tamil Nadu

MORE RETAIL LIMITED

(Formerly known as Aditya Birla Retail Limited)

5th Floor, Near Mittal Industrial Estate, Andheri Kurla Road, Andheri (East), Mumbai 400059, India.
☎ +91 8652905555 | E: contactus@morestore.com | W: www.morestore.com

Corporate ID No : U65990MH1988PLC048117

THE RAMCO CEMENTS LIMITED

Corporate Office:

Auras Corporate Centre, V Floor,
98-A, Dr. Radhakrishnan Salai, Mylapore,
Chennai - 600 004, India.

Tel: +91 44 2847 8666 Fax: +91 44 2847 8676

Website: www.ramcocements.in

Corporate Identity Number: L26941TN1957PLC003566

20th May 2019

TO WHOMSOEVER IT MAY CONCERN

This is to certify that Mr. Ahamed Basha S final year MBA Student, from Department of Management Studies, B.S. Abdur Rahman, Crescent Institute of Science and Technology, Chennai, has successfully completed his Project titled "A Study on Cement Dispatch Section" at The Ramco Cements Limited, during 20th March 2019 to 20th May 2019.

We wish all the best in his future endeavor.

For THE RAMCO CEMENTS LIMITED



COMPLETION LETTER FROM THE COMPANY:

Agility
3rd Floor,
Marol Maroshi Road - 400 059
Chennai - 600 017
Tel: +91 44 3096 3198



Date: 21-May-2019

**CERTIFICATE OF COMPLETION OF
INTERNSHIP PROGRAMME**

This is to certify that Mr. Ahmed Sheriff M has completed the unpaid internship program at Agility Logistics Pvt Ltd, Chennai. For a period of 60 days, starting from 01- April -2019 till 21- May- 2019. He has done his work report with Ocean Import & Export department.

His performance during the internship is good.

For Agility Logistics Pvt. Ltd.



(Signature)

BUNDL TECHNOLOGIES PRIVATE LIMITED

TO WHOM SO EVER IT MAY CONCERN

We hereby acknowledge that Anisha K.S. student of B.S Abdur Rahmian Crescent institute commerce and technology has interned in our organization, Swiggy (Bundl Technologies Pvt. Ltd.) from 21-Mar-19 to 21-May-19. Her work was on a project "Work report on Sales and Promotional Activities".

During her tenure, we found her to be an enthusiastic contributor and a keen learner. She was part of our Sales team.

We deeply appreciate her for her commitment towards the tasks assigned to her quality of work.

We wish Anisha K.S the best in her studies and future career.

For Swiggy,
Bundl Technologies Pvt. Ltd.

Swiggy
HR - Human Resources

www.swiggy.com | hr@swiggy.in | 000 4091 5278

Head Office: 4th Floor, Annex Building, Maruthi Chambers, Survey No. 17/9B, Begur Hobli, Roopena Agrahara, Bengaluru, Karnataka, India 560068. CIN: U72200KA2013PTC096530
Corporate Office: 4th Floor, Tower D, IBC Knowledge Park, Bannerghatta Main Road, Bellandur, Bengaluru, Karnataka, India - 560029



B.S. Abdur Rahman Crescent

Institute of Science & Technology
Deemed to be University u/s 3 of the UGC Act, 1956
GST Road, Vandalur, Chennai 600 048

BONAFIDE CERTIFICATE

Certified that this project report **A STUDY ON EXPORT DOCUMENTATION CLEARANCE PROCEDURE WITH REFERENCE TO WHITE HOUSE GARMENTS** is the bonafide work of **M. ASARUDEEN(RRN: 170292601060)** who carried out the project work under my supervision. Certified further, that to the best of my knowledge the work reported herein does not form part of any other project report or dissertation on the basis of which a degree or award was conferred on an earlier occasion on this or any other candidate.

SIGNATURE

MRS.AHKILA

HR

White house

no: 6 nandhivaram village,

guduvanchery, chennai

WHITE HOUSE

No. 6, G.S.T. ROAD,
NANDHIVARAM VILLAGE,
GUDUVANCHERY-603 202.
TIN : 33160520457

SIGNATURE

DR.M.SHANMUGAM

Head of the Department

Department of Management Studies

B.S.A Crescent Institute of Science & Technology

Vandalur, Chennai – 600 048

Phoenix

ganesha nagar , 2 nd main road,

1101.

Chennai

Sub: Appointed as HR EXECUTIVE

With reference to your application for a suitable placement in our organization and the interview you had with us, we are pleased to offer you an appointment in Phoenix Consultancy Services, as HR EXECUTIVE on the following terms and Conditions:

Commencement of Employment:

Your employment will commence on 01.04.2019.

You would be a part of the Education Business Group and shall be reporting to the CEO or officer nominated by her. During your Service period, the Company reserves the right to transfer you to any other Department within the Company or Client on your willingness.

Probation and Remuneration:

You will be on probation for 3 months and your employment with the company will be confirmed based on your performance. During your probation period, you need to handover any personal academic certificates to the company and the same will be returned to you on your request to the company.

You shall be paid a Monthly gross Salary of Rs.10000. This shall be paid on the 7th of each subsequent Month, or on the preceding working day, whichever is earlier.

It is agreed that it shall be open to the company from time to time to vary any remuneration, benefits, facility, or perquisite that may be extended to you on a review of the company's decision.

Acceptance of Appointment Letter:

You shall intimate your acceptance of this letter within today, failing which the letter of appointment will be withdrawn and cancelled automatically without any further communication in this regard.

Phoenix Consultancy Services

ganesha nagar West Extn, Chennai - 600 101. Ph : +91 44-42645202,
www-phoenix-tcs.com, www. phoenix-tcs.com



10th May, 2019

The Department of Management studies,
Baskar Rahman Crescent Institute of Science and Technology
Chennai, Chennai.

Dear Sir/ Madam,

It is to certify that Mr. **BASKAR SUBIRAMANI** (Emp. Code: 99007622) is working with us since 28-
March-19. His current office address is:

Canara HSBC Oriental Bank of Commerce Life Insurance Co. Ltd.
Mezzanine Floor, Wescare Tower, Door No. 16 (16/1 and 16/2),
Senathipathi Road, Teynampet, Chennai - 600018 Tamil Nadu

This letter is being issued to him on his request to submit in his college.

Thanking you.

Yours faithfully,

For Canara HSBC Oriental Bank of Commerce Life Insurance Company Limited



Anand Kumar Das

Assistant Vice President – Human Resources

Mando Automotive India Private Limited

(Formerly Mando Automotive India Limited)

Plot No. S1A & S5 SIPCOT Industrial Park, Vengadu Village, Pillaipakkam Post, Sriperumbudur Taluk,
Sriperumbudur - 602 105, India. Tel.: 91-44-71800300, Fax: +91-44-71800530 Web: www.mandoindia.com

May.18, 2019

TO WHOMSOEVER IT MAY CONCERN

It is to certify that Ms. V. Deepika (Reg. No: 170292601064) II Year, M.B.A
(Finance and HR) Student of B.S Abdur Rahman Crescent Institute of Science
and Technology, Chennai has undergone an Internship training at our
Organization from Apr.19, 2019 to May.18, 2019. During this period she was
found to be excellent and adaptive.

Wishes her all the best in rest of her career.

Mando Automotive India Pvt. Ltd.



HR Manager - HR

SIPCOT Industrial Park, Irungattukottai, Sriperumbudur Taluk, Kanchipuram Dist., Tamil Nadu-602 117, India.

Tel: 91-44-49231111 Fax: 91-44-71800530 CIN No. U50300TN2006FTC061618

Mando

ANAND 

Mando Automotive India Private Limited

(Mando Automotive India Limited)

Plot No. 51A & 55 SIPCOT Industrial Park, Vengadu Village, Pillaipakkam Post, Sriperumbudur Taluk,
Sriperumbudur - 602 005, India. Tel.: 91-44-71800300, Fax: +91-44-71800530 Web: www.mandoindia.com

May.18, 2019

TO WHOMSOEVER IT MAY CONCERN

I hereby certify that Ms. V. Deepika (Reg. No: 170292601064) II Year, M.B.A
(Finance and HR) Student of B.S Abdur Rahman Crescent Institute of Science
and Technology, Chennai has undergone an Internship training at our
organization from Apr.19, 2019 to May.18, 2019. During this period she was
found to be excellent and adaptive.

Wishing her all the best in rest of her career.

Mando Automotive India Pvt. Ltd.

Manager - HR

SIPCOT Industrial Park, Irungattukottai, Sriperumbudur Taluk, Kanchipuram Dist., Tamil Nadu-602 117, India.
Phone No: 44-49231111 Fax: 91-44-71800530 CIN No. U50300TN2006FTC061618

ANAND 

18.03.2019

Department of Management Studies,
Sri Sankar Institute of Science & Technology

Subject: Project Acceptance Letter from SEAWAVES SHIPPING SERVICES,

Respected Sir,

Herewith the acceptance of the Project duration for two month for the student **Mr. M. Elavarasan**,
Reg: (17N292601065). We confirm the fullest support to undergo the project by way of teaching in
terms of practical and theoretical way along with the interest of the student.

We wish him Good Luck to be the successful training period as well as we wish him to be our part of
our company during the project period.

Apart from the above we expect to maintain discipline and punctual regulations during the tenure
period of project.

Best Regards,

For: SEAWAVES SHIPPING SERVICES



Authorized Signatory

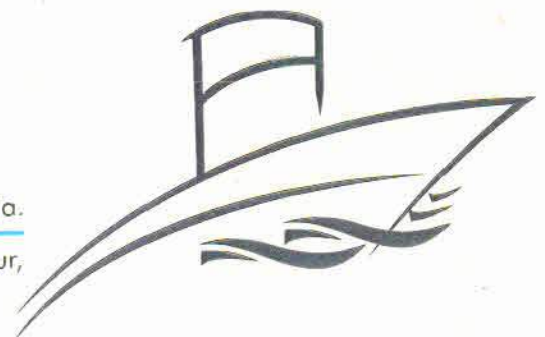



B.S. Abdur Rahman
Crescent

Institute of Science & Technology
Deemed to be University u/s 3 of the UGC Act, 1956
GST Road, Vandalur, Chennai 600 048

BONAFIDE CERTIFICATE

Certified that this project report **A STUDY OF ERRECTIVENESS OF SALES PROMOTIONS IN RELIABLE TRADE LINKS** is the bonafide work of **V. HARISH (RRN: 1925251066)** who carried out the work report under my supervision. Certified further, that to the best of my knowledge the work reported herein does not form part of any other project report or dissertation on the basis of which a degree or award was conferred on any earlier occasion on this or any other candidate.

S. Shanmugam
SIGNATURE
23/05/19

DR. SHANMUGAM

SUPERVISOR

Assistant Professor

Department of Management Studies

B.S.A Crescent Institute of Science & Technology

Chennai - 600050, Vandalur,

J. T. Tamilselvan
SIGNATURE

Mr. J. TAMILSELVAN

MANAGING PARTNER

Reliable Trade Links

65, Balaji Nagar, Padi,

Chennai - 600 048

SIGNATURE

DR. SHANMUGAM MUNUSWAMY

Head of the Department

Department of Management Studies

B.S.A Crescent Institute of Science & Technology, Vandalur, Chennai - 600 048

BONAFIDE CERTIFICATE



**Bescal
Steel
Industries**

20/03/2019
Chennai

TO WHOMSOEVER IT MAY CONCERN

Note: Confirmation letter for MBA Internship

We hereby confirm the below student who is pursuing final year MBA in B.S Abdur Rahman Crescent Institute of Science and Technology, Chennai has been offered to do the final year internship in Marketing from Mar'2019 to May'2019.

NAME: Hayaz Khan .H

REG NO : 170292601067

We wishes to complete this internship successfully.

For Bescal Steel Industries Pvt. Ltd,

BESCAL STEEL INDUSTRIES
1718, New Avenue, Velri Nagar,
Bishwas Mannady, Chennai - 600 001.
Authorized Signatory

BESCAL STEEL INDUSTRIES PVT LTD

1718, New Avenue, Velri Nagar, Mannady, George Town,

Chennai - 600 001 | www.bescalsteelindustries.com | Ph: 044 - 22449774



SALT SHIPPING LINES

21.05.2019

TO WHOMSOEVER IT MAY CONCERN

Re: Completion internship of final year MBA.

We wish to confirm that Mr. **Jahabarrilvan.M** (Reg no: **170292601068**),
pursuing final year MBA in B.S Abdur Rahman Crescent Institute of Science
and Technology, Chennai has successfully completed the internship in our
company from **25.03.2019** to **14.05.2019**.

He has chosen the Shipping & Logistics Management field in MBA
program and selected in Documentation & Operations.

SALT SHIPPING LINES



GEORGE ALAUDEEN
(MANAGING PARTNER)





B.S. Abdur Rahman
Crescent
Institute of Science & Technology
Deemed to be University u/s 3 of the UGC Act, 1956
GST Road, Vandalur, Chennai 600 048

BONAFIDE CERTIFICATE

Certified that this project report **A STUDY ON ASSESSING**

ORGANIZATIONAL ROLE STRESS LEVEL OF EMPLOYEES is the bonafide

work of **JEEVA V.P** (RRN: 170292601069) who carried out the project work

under my supervision. Certified further, that to the best of my knowledge the work

mentioned herein does not form part of any other project report or dissertation on the

subject for which a degree or award was conferred on an earlier occasion on this or any

other certificate.

[Handwritten Signature]
23/05/19

SUPERVISOR

Assistant Professor

Department of Management Studies

B.S.A Crescent Institute of

Science & Technology

Vandalur, Chennai - 600 048

[Handwritten Signature]
SIGNATURE

N.Surendhar

Joint supervisor

Human Resource

Victory Software Solutions.

N90/342, Vijaya Complex,

Arcot Road, Kodambakkam,

Chennai - 600 024.

SIGNATURE

Dr. Shanmugam

Head of the Department

Department of Management Studies

B.S.A Crescent Institute of Science & Technology

Vandalur, Chennai - 600 048

CONFIRMATION LETTER FROM THE COMPANY



Internship Letter

28 March 2019

M. Karthikeyan R
105, Ambegam Illam
Plot No. 1, Jesupadham Street
Chennai, Chennai - 600 044.

Dear Karthikeyan,

We would like to congratulate on being selected for internship with Innova Solutions Private Limited based at Chennai. Your training is scheduled to start effective from 25 March 2019.

In such your internship will include training/orientation and focus primarily on learning and developing new skills.

Project : BGC Process - Human Resources

Stipend : INR 10,000 per month

We look forward to working with you!

The Innova Solutions Pvt. Ltd.

Anand Sakthivel
Associate Vice President - Human Resources

INNOVA SOLUTIONS PRIVATE LIMITED
105, Ambegam Illam, Chennai - 600 044
Plot No. 1, Jesupadham Street, Chennai - 600 044
www.innovasolutions.com





B.S. Abdur Rahman
Crescent

Institute of Science & Technology
Deemed to be University u/s 3 of the UGC Act, 1956
GST Road, Vandalur, Chennai 600 048

BONAFIDE CERTIFICATE

Certified that this work report is the bonafide work of **S. KOUSALYA** (RRN: 1102020511071) who carried **A STUDY ON INVESTORS OPINION ABOUT MUTUAL FUNDS** and the work report under my supervision. Certified further, that to the best of my knowledge the work reported herein does not form part of any other work report or dissertation on the basis of which a degree or award was conferred on an earlier occasion on this or any other candidate.

SIGNATURE 23/05/19

Dr. S. PANSOLI

SUPERVISOR

Associate Professor

Department of Management Studies

B.S. Abdur Rahman Crescent Institute of Science

& Technology

Vandalur, Chennai – 600 048

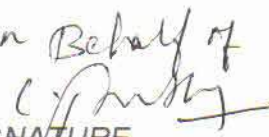
On Behalf of

SIGNATURE

THULASI RAGHAVAN

RETAIL SALES MANAGER

Taurus Mutual Mgmt Company

No.92, G.N. Chetty Road

Thiyagaraya Nagar

Chennai – 600 017

SIGNATURE

Dr. Shanmugam

Head of the Department

Department of Management Studies

B.S.A Crescent Institute of Science & Technology

Vandalur, Chennai - 600048



Crescent

B.S. Abdur Rahman

Institute of Science & Technology
Deemed to be University u/s 3 of the UGC Act, 1956
GST Road, Vandalur, Chennai 600 048

BONAFIDE CERTIFICATE

The project report **A STUDY ON THE IMPACT OF PSYCHOLOGICAL
STRESS ON EMPLOYEE STRESS WITH REFERENCE TO TATA FICOSE
AUTOMOTIVE SYSTEM PRIVATE LIMITED** is the bonafide work of **R.KRITHEKA
(REGISTRATION NO: 172)** who carried out the project work under my supervision.
To the best of my knowledge the work reported herein does not
resemble any other project report or dissertation on the basis of which a degree or
diploma was conferred on an earlier occasion on this or any other candidate

G. Rocky Devi
24/5/19

SIGNATURE

MRS.ANITHA.N

HR HEAD

DR. M. SHANMUGAM ROCKY DEVI

ASSISTANT PROFESSOR

**DEPARTMENT OF MANAGEMENT STUDIES TATA FICOSE AUTOMOTIVE SYSTEM
CRESCENT INSTITUTE OF PVT LTD, INDUSTRIAL ESTATE
OF SCIENCE AND TECHNOLOGY MARAIMALAR NAGAR-603 209**

SIGNATURE

DR.M.SHANMUGAM

PROFESSOR AND HEAD

DEPARTMENT OF MANAGEMENT STUDIES

B.S ABDUR RAHMAN INSTITUTE

OF SCIENCE AND TECHNOLOGY

VANDALUR-600 048



B.S. Abdur Rahman
Crescent
Institute of Science & Technology
Deemed to be University u/s 3 of the UGC Act, 1956
GST Road, Vandalur, Chennai 600 048

BONAFIDE CERTIFICATE

Certified that this project report **RISK AND RETURN ANALYSIS FOR SELECTED POWER SECTOR SECURITIES** is the bonafide work of **SHANMUGAM** (RRN: 170292601073) who carried out the project work under my supervision. Certified further, that to the best of my knowledge the work reported herein does not form part of any other project report or dissertation on the basis of which a degree or award was conferred on an earlier occasion on this or any other candidate.

SIGNATURE 23/05/19
DR SHANMUGAM
SUPERVISOR
Associate Professor
Department of Management Studies
B.S. A Crescent Institute of
Science & Technology
Vandalur, Chennai - 600 048

SIGNATURE
MR H DEEPAK
SUPERVISOR
Payment Department
Redington (India) Limited
Plot. Nos.8 & 11(SP)
Guindy, Chennai-600032

SIGNATURE
Dr Shanmugam
Head of the Department
Department of Management Studies
B.S. A Crescent Institute of Science & Technology
Vandalur, Chennai - 600 048



15th April 2019

Mr. M. Rahman
Head of the Department
Department of Management Studies
Government Institute of Science and Technology,
Chennai - 600048

Dear Sir/Madam,

In reference to your request letter dated 12th April 2019, we are pleased to inform that Mr. M. Asraf Ali P (Reg No.170292601074) pursuing second year MBA is permitted to undergo internship in our organization.

The period of internship will be from 18th March 2019 to 25th May 2019.

Yours faithfully,
Rao R
General Manager - HR

TVS Electronics Limited



**Bescal
Steel
Industries**

06/05/2019
Chennai

TO WHOMSOEVER IT MAY CONCERN

Reference letter for MBA Project

I hereby confirm the below student who is pursuing final year MBA in B. S. Abdur
Rahman College of Science and Technology, Chennai has successfully completed the final year
project titled **"A STUDY ON EFFECTIVENESS OF SALES PROMOTIONAL
ACTIVITIES"** from 01st Apr'2019 to 06th May'2019.

NAME: Mohamed Azarudeen. S

REG NO: 170292601075

His conduct & behavior was observed to be good.

For Bescal Steel Industries Pvt. Ltd,

BESCAL STEEL INDUSTRIES

1/18, New Avenue, Vetri Nagar,
Mannady, Chennai - 600 001.

Authorized Signatory

BESCAL STEEL INDUSTRIES PVT LTD

Vetri Nagar, Mannady, George Town,

www.bescalsteelindustries.com | Ph: 044 - 22449774



B.S. Abdur Rahman
Crescent

Institute of Science & Technology
Deemed to be University u/s 3 of the UGC Act, 1956

BONAFIDE CERTIFICATE

Whereas that this work project report at ALLWIN MOTORS is the bonafide work of **MOHAMED**
DAWUD ALI S (RRN: 170292601078) who carried out the work report under my supervision. Certified
that to the best of my knowledge the work reported herein does not form part of any other
research report or dissertation on the basis of which a degree or award was conferred on an earlier
candidate or this or any other candidate.

DR. SHANMUGAM. M

HEAD OF THE DEPARTMENT

ASSISTANT PROFESSOR

B.S. Abdur Rahman Crescent Institute Of
Science And Technology

SIGNATURE

DAWOOD ALI. S

MANAGER

ALLWIN MOTORS

Muthupet

SIGNATURE

DR. SHANMUGAM. M

HEAD OF THE DEPARTMENT

B.S. ABDUR RAHMAN CRESCENT INSTITUTE OF

SCIENCE AND TECHNOLOGY, VANDALLOOR, CHENNAI 48



B.S. Abdur Rahman
Crescent

Institute of Science & Technology
Deemed to be University u/s 3 of the UGC Act, 1956
GST Road, Vandalur, Chennai 600 048

BONAFIDE CERTIFICATE

Certified that this project report **A STUDY ON EMOTIONAL INTELLIGENCE OF EMPLOYEES IN STEADFAST INTERNATIONAL PVT LTD** is the bonafide work of **MUHAMMAD SHAHID (RRN: 170292601079)** who carried out the project work under my supervision. Certified further, that to the best of my knowledge the work reported herein does not form part of any other project report or dissertation on the basis of which a degree or award was conferred on an earlier occasion on this or any other candidate.

SIGNATURE 23/05/19

DR SHANMUGAM
SUPERVISOR

Associate Professor
Department of Management Studies
B.S. A Crescent Institute of
Science & Technology
Vandalur, Chennai - 600 048



SIGNATURE

MR ATAULLAH
SUPERVISOR

Executive Officer
Steadfast International Pvt Ltd
238/215, Thambu Chetty Street
Chennai - 600 001

SIGNATURE

Dr Shanmugam

Head of the Department

Department of Management Studies
B.S. A Crescent Institute of Science & Technology
Vandalur, Chennai - 600 048



**B.S. Abdur Rahman
Crescent**

Institute of Science & Technology
Deemed to be University U/s 3 of the UGC Act, 1956
GST Road, Vandalur, Chennai 600 048

BONAFIDE CERTIFICATE

Certified that this project report **A STUDY ON STRATEGIES FOR IMPROVING HRD ACTIVITIES** is the Bonafide work of **R. MOHAMMED YUSUF** (RRN: 170292601080) who carried out the project work under my supervision. Certified further, that to the best of my knowledge the work reported herein does not form part of any other project report or dissertation on the basis of which a degree or award was conferred on an earlier occasion on this or any other candidate.

Prasanna Venkatesh
SIGNATURE 24/05/19

SIGNATURE

DR. S. PRASOLU

MR. PRASANNA VENKATESH

SUPERVISOR

JOINT SUPERVISOR

Associate Professor

Deputy officer- HR

Department of Management Studies

RAMCO CEMENTS

B.S. Abdur Crescent Institute of

ALATHIYUR.

Science & Technology

Vandalur, Chennai – 600 048

SIGNATURE

Head of the Department

Department of Management Studies

B.S. Abdur Crescent Institute of Science & Technology

Vandalur, Chennai – 600 048



B.S. Abdur Rahman
Crescent
Institute of Science & Technology
Deemed to be University u/s 3 of the UGC Act, 1956
GST Road, Vandalur, Chennai 600 048

BONAFIDE CERTIFICATE

Certified that this project report **STUDY ON CUSTOMER EXPECTATION OF HYUNDAI** is the Bonafide work of **Z. MOHAMMED ZULWAQAR (RRN:)** who carried out the project work under my supervision. Certified further, to the best of my knowledge the work reported herein does not form part of any report or dissertation on the basis of which a degree or award was conferred at an earlier occasion on this or any other candidate.

SIGNATURE

JAGANATH E

MANAGER HR&ADMIN

NEW NUM 162

Church road

Kappali thottam

Vandalur,

Chennai – 600 048

SIGNATURE

Dr. SHANMUGAM

Head of the Department

Department of Management Studies

B.S. Abdur Crescent Institute of Science & Technology

Vandalur, Chennai – 600 048



B.S. Abdur Rahman
Crescent

Institute of Science & Technology
Deemed to be University u/s 3 of the UGC Act, 1956
GST Road, Vandalur, Chennai 600 048

BONAFIDE CERTIFICATE

Certified that this project report "A STUDY ON CONSUMER PERCEPTION ABOUT HEALTH INSURANCE" is the Bonafide work of **S.MUKTHAR (170292601082)** who carried out the project work under my supervision. Certified further, that to the best of my knowledge the work reported herein does not form part of any other project report or dissertation on the basis of which a degree or award was conferred on an earlier session on this or any other candidate.

S. Parthiban
23/05/19
SIGNATURE
S. PARIBOLU
ASSISTANT PROFESSOR

Department of management studies
B.S. Abdur Rahman -
Crescent Institute of science & technology,
Vandalur, Chennai - 600048.

SIGNATURE
Mr.JESUBALAN
GENERAL MANAGER
Aditya birla health insurance
(India) Pvt. Ltd.,

mc nicholas Street,
chetpet,
Chennai-600001.India
PH: 09444056340

SIGNATURE
Head of the department
Department of management studies
B.S.Abdur Rahman institute of science and technology
Vandalur, Chennai-600 048



aapke vaade,
sar aankhon par

10th May, 2019

To
The Department of Management studies,
B.S Abdur Rahman Crescent Institute of Science and Technology
Vandalur, Chennai.

Dear Sir/ Madam,

This is to certify that Mr. **MUTHUPANDIAN PALANISAMY** (Emp. Code: 99007621) is working with us since 28-March-19. His current office address is:

Canara HSBC Oriental Bank of Commerce Life Insurance Co. Ltd.
Mezzanine Floor, Wescare Tower, Door No. 16 (16/1 and 16/2),
Cenotaph Road, Teynampet, Chennai - 600018 Tamil Nadu

This letter is being issued to him on his request to submit in his college.

Thanking you.

Yours faithfully,
For Canara HSBC Oriental Bank of Commerce Life Insurance Company Limited

Arun Kumar Das
Assistant Vice President – Human Resources



B.S. Abdur Rahman
Crescent
Institute of Science & Technology
Deemed to be University u/s 3 of the UGC Act, 1956
GST Road, Vandalur, Chennai 600 048

BONAFIDE CERTIFICATE

Certified that this project report **A STUDY ON INVENTORY MANAGEMENT WITH REFERENCE TO ALLOYSYS EXTRUSION P LTD** is the bonafide work of **GANESH KANAKIAN** (RRN: 170292601085) who carried out the project work under my supervision. Certified further, that to the best of my knowledge the work reported here in does not form part of any other project report or dissertation on the basis of which a degree or award was conferred on an earlier occasion on this or any other candidate.

S. Panboli
23/05/19

SIGNATURE
Dr. S. PANBOLI

SUPERVISOR

Associate Professor
Department of Management Studies
B.S. Abdur Rahman Crescent Institute of
Science & Technology
Vandalur, Chennai – 600 048

Francis Xavier
SIGNATURE

FRANCIS XAVIER

HR manager

alloysys extrusion p ltd
No. 122A, 27th street

sidco industrial estate
ambattur, Chennai 58

SIGNATURE

DR. SHANMUGAM MUNUSWAMY
Prof & Head of the Department

Department of Management Studies
B.S. Abdur Rahman Crescent Institute of Science & Technology

Vandalur, Chennai – 600 048

Subject: Internship Letter

Following your application and the subsequent interview you had with us, we are pleased to offer you internship as Trainee

at Chennai and will report to Assistant Manager.

The internship period will be for a period of three months from 21/03/2019 to 24/05/2019. During this period you will be paid (Rupees Eight thousand Only) per month (subject to tax).

You are requested to join on or before: 21-Mar-2019 and provide your acceptance of this offer via mail within 3 days from receipt of this letter. If you fail to do so, your Internship would stand null and void.

You are requested to carry with you the following documents (originals and one xerox copy), as applicable, on the day of your joining to complete your joining formalities:

- 1. Educational Qualification - SSC/HSC/Graduation/Post Graduation/Diploma
- 2. Date of Birth proof - Passport/Birth Certificate/School Leaving Certificate
- 3. Experience certificates of previous organizations, Copy of Relieving letter and Resignation acceptance letter of your last organization
- 4. Salary slip for last 3 months salary drawn salary
- 5. Residential address proof/Copy of Leave and License Agreement
- 6. PAN Card (Mandatory)
- 7. Two Passport Size recent colour photographs

The terms and conditions of your Internship letter will not be considered to be changed / deemed to be changed unless they are communicated to you in writing.

This letter is being issued hereof as a token of your acceptance.

We look forward to welcoming you on board at the earliest.

INTEGRATED SERVICES PRIVATE LIMITED

Human Resources

Integrated Services Private Limited



FS 581351

MD 608090

IS 683020

OHS 697114

NOTIFICATION LETTER FROM THE COMPANY



Name	G Gowrishankar
Department	HR
	Human Resources
Telephone	+91 (44) 37174022
Fax	+91 (44) 26811257
Mobile	+91 9940665602
E-mail	Gowrishankar.g@siemens.com
Your letter of	
Our reference	ESS/SL/SR/CHE
Date	25.03.2019

Dear Mr. Praveen E,

Based on the request from your Institute, we are pleased to intimate you that the following student Mr. Praveen E from your college can undergo the project in our company commencing from 25/03/2019 on the following terms and conditions:

1. You will be given Training for a period from 25/03/2019 to 25/05/2019. The training will automatically conclude w.e.f. the closing hours of 25th May 2019.
2. Advise you to report at Chennai office, on the schedule day of training to Mr. Rajib Ghoshal (Business Administration Manufacturing Manager). You will not be entitled to any payment for the period of your training.
3. No optical /magnetic media such as floppy disks, magnetic tape cartridge, digital audio tapes, magnetic tapes, hard disks, optical disks, CD-ROMs etc. shall be allowed to be brought into or taken out by you from SL premises.
4. No documentation in paper form pertaining to the project/s to which you have been assigned shall be taken out by you.
5. You will not be allowed to work on a terminal, PC, workstation or computer system other than the one assigned to you by the Officer-in-charge.
6. The Company reserves the right to terminate your training without notice or without assigning any reason.

Please return the copy of this letter duly countersigned in token of your acceptance of these terms and conditions.

Yours Faithfully,
SIEMENS LTD.

Gowrishankar G
Sr Process Lead – HR Services

Restricted

Siemens Ltd.
Chennai

Postal Address	Tel +91 44 37174000
306/2 'A' Block 'D', Chettipadu	Fax +91 44 26811257
Village, Thandaram Post	
Sr-perumbudur - 602105	

Registered Office: Birla Aurno, Level 21, Plot No 1080, Dr. Annie Besant Road, Worli, Mumbai 400 030, Telephone +91 22 24987000, Fax +91 22 24987500
Sales Office: Ahmedabad, Bengaluru, Chandigarh, Chennai, Coimbatore, Hyderabad, Kharagpur, Kolkata, Lucknow, Mumbai, Nagpur, New Delhi, Pune, Vadodara
Company Identity Number: L28920MH-1957/PCO10939

17th May' 2019

TO WHOMSOEVER IT MAY CONCERN

Completion of MBA Project

This is to certify that Mr. Pravin Kumar. V (Reg. No: 170292601088) who is pursuing final year MBA in B.S Abdur Rahman Crescent Institute of Science and Technology, Chennai has successfully completed the HR project in our concern titled "A STUDY ON RECRUITMENT AND SELECTION PROCESS" from 18th Mar' 2019 to 17th May' 2019

During the tenure with us, conduct & behavior was observed to be good.

Signware Technologies,



Signware Technologies Pvt. Ltd

Signware Technologies Pvt. Ltd., Balavinayagar Nagar, Arumbakkam, Chennai - 600 106.

www.signwaretechnologies.com | 7299159966

TO WHOMSOEVER IT MAY CONCERN

This is to certify that Mr. Prem Kumar R, is permitted to undergo internship in our organization from 25th March 2019 to 20th May 2019 as a part of his MBA – Management Studies curriculum at B.S. Abdur Rahman Crescent Institute of Science & Technology.

Revone8 HR Consulting Services



Samuel Wilson
Chief Executive Officer





B.S. Abdur Rahman
Crescent
Institute of Science & Technology
Deemed to be University u/s 3 of the UGC Act, 1956
GST Road, Vandalur, Chennai 600 048

BONAFIDE CERTIFICATE

Certified that this project report **A STUDY ON EFFECTIVENESS OF THE INTERNET AS A RECRUITMENT SOURCE** is the bonafide work of **V.RAHAMATH** (REG. NO. RRN-17029261090) who carried out the project work under my supervision. Certified further, that to the best of my knowledge the work reported herein does not form part of any other project report or dissertation on the basis of which a degree or award was conferred on an earlier occasion on this or any other candidate.

SIGNATURE

R. Rocky Devi
24/5/19

Dr. R. Thirumalambam Rocky Devi

ASSISTANT PROFESSOR

Department of Management Studies

B.S.A. Crescent Institute of

Science & Technology

Vandalur, Chennai-600 048

L. Sririchandrasekar
SIGNATURE

Mr.L.SRICHANDRASEKAR

HR- THG Publishing Private Limited

KASTURI BUILDINGS

ANNA SALAI

Chennai -600 002

SIGNATURE

Head of the Department

Department of Management Studies

B.S.A Crescent Institute of Science & Technology

Vandalur, Chennai – 600 048



Mr. Ranjith Kumar.P,

Class: MBA,

Professor Rahman crescent institute of science and technology,

Chennai-600048.

Project confirmation for the Period 1st April 2019 to June 2019

Dear Ranjith kumar

We are pleased to inform you that you can do your project with us during the above period. You are expected to be in the premises from 9am to 6pm with two 15 minutes breaks. You will be considered as the project trainee and will report to the Managing Director Lucian

Kindly bring a copy of this letter with you when you report to your project. Let us know your confirmation as soon as you receive this letter.

We wish you all the best.

Best Regards,

Managing Director,

Display India Pvt Ltd.

DISPLAY INDIA PVT LTD.

[Handwritten signature]
DIRECTOR

Engineer

98425100

98425100

Chempalayam Village, Sular Taluk,
Tamil Nadu, India 641 402.

infinitegroup.in



Scan The Above Code To View Us Online



B.S. Abdur Rahman

Crescent

Institute of Science & Technology

Deemed to be University u/s 3 of the UGC Act, 1956

BONAFIDE CERTIFICATE

I hereby certify that this project report on **A STUDY ON WAREHOUSE MANAGEMENT** is the original work of **M.RIYAZ AHAMED(RRN: 170292601093)** who carried out the project under my supervision. Certified further, that to the best of my knowledge the work herein does not form part of any other project report or dissertation on the basis of which a degree or award was conferred on an earlier occasion on this or any other candidate.

SIGNATURE
DR. ROCKY DEVI
SUPERVISOR
Assistant Professor,
Department of Management Studies

Crescent Institute of Science & Technology
Chennai - 600 048.

SIGNATURE
Ms. AKILA
JOINT SUPERVISOR
HR Manager,
White House Business Solutions
Pvt.ltd,
Guduvanchery, Chennai-603202.

SIGNATURE
Head of the Department
Department of Management Studies
B.S. A Crescent Institute of Science & Technology
Vandalur, Chennai - 600 048.

COMPLETION LETTER FROM THE COMPANY:



18-March-2019

CERTIFICATE OF COMPLETION OF INTERNSHIP PROGRAMME

This is to certify that Mr. Shabaaz Ahmed M has completed the unpaid internship program at e-ship Global Logistics Chennai. For a period of 60 days, starting from 18-March 2019 till 17-May-2019. He has done his work report with Ocean Import & Export Department.

His performance during the internship is good.

Signature

Head Office Global Logistics



TO WHOMSOEVER IT MAY CONCERN

This is to certify that G. Shabnam, MBA student of B.S. Abdur Rahman Crescent Institute of Science and Technology, has successfully completed her internship from 15th March 2019 - 10th May 2019 in Graduate Talent program at Virtusa IT Consulting Services Private Limited, Chennai.

- Designation : Intern
- Tier : Tier 5
- Track : Shared Services

Arthivasan S

Associate Manager- Shared Services



Virtusa Consulting Services Private Limited

Address: 20th Block DLF IT Park-SEZ, 1/124 Mount Poonamalee Road, Shivaji Garden Moonlight Stop, Nandambakkam Post,
Chennai - 600 089.

Phone: +91 44 3927 7800 | F: +91 44 3927 7800 | www.virtusa.com

Head Office: Virtusa Consulting Services Private Limited, Sy. No.115/part, Plot No-10, Nanakramguda Village,
R.R Dist, Hyderabad - 500032. T: +91 40 44528000

Phone: +91 40 44528000



MBL HR CORP/2019

21st May 2019

TO WHOMSOEVER IT MAY CONCERN

This is to certify that Mr. Sheik Mohamed A, MBA from B.S.A. Crescent University has successfully completed his project titled "An Analysis on the impact of Supply Chain Management on the sales of Rane Brake Lining" in our organization from 12th March to 21st May 2019.

We wish him all the best for his Future endeavors.

For Rane Brake Lining Limited

G. Govardhanan
General Manager-HR

TEG PUBLISHING PRIVATE LIMITED

100/102/103, Kasturi Buildings, Anna Salai, Chennai -600 002
CIN: U22300TN2017PTC115593

18th May, 2019.

Prof. Dr. Shamuga Sundaram,
Head of the Department,
Department of Management Studies,
B.S. Abdur Rahman Crescent Institute of Science & Technology,
Chennai - 600 048.

Dear Madam,

Internship Completion letter

We hereby certify that Ms. Sinduja R (Reg. No. 170292601099), undergoing Master of Business Administration from B.S. Abdur Rahman Crescent Institute of Science & Technology, Chennai, has successfully completed her two months of internship program (18th March 2019 to 20th May 2019) at our corporate office.

During her Internship Program she showed very keen interest in learning our business structure, management policies, organization structure and other related area.

We wish her all the very best!

Sincerely,

Signature

Head - Human Resources

Internal Customer Focus Functions



B.S. Abdur Rahman
Crescent

Institute of Science & Technology
Deemed to be University u/s 3 of the UGC Act, 1956
GST Road, Vandalur, Chennai 600 048

BONAFIDE CERTIFICATE

Certified that this project report is the bonafide work "A STUDY ON EFFECTIVE ROLE OF EMPLOYEES OF VGS & CO" of MR. K.SRI KRISHNA (PIN: 170292601101) who carried out the project work under my supervision. Certified further, that to the best of my knowledge the work reported herein does not form part of any other project report or dissertation on the basis of which a degree or award was conferred on an earlier occasion on this or any other candidate.

SIGNATURE

DR. D. ASOKK
SUPERVISOR

Department of Management Studies
Assistant Professor
B.S. Abdur Rahman Crescent Institute of
Department of Management
Science & Technology

SIGNATURE

PRATEEK MANGAL
MARKETING MANAGER

VGS & Co, No.3B/1,
Jeevarathinam street, KSR Nagar
Chennai - 600053

SIGNATURE

M. SHANMUGAM

Head of the Department

B.S. Abdur Rahman Crescent Institute of Vandalur, Chennai – 600 048
Science & Technology, Vandalur, Chennai – 600 048

ULTIMATE CONTAINER SERVICES

No.41, Ayyanarkoil Street, S.R. Palayam, Gounderpalayam,, Chennai - 600 120

E-Mail: balamurugan@ultimatecontainer.in

website: www.ultimatecontainer.co.in

15th May 2019

Whomsoever it may concern

For completion of final year MBA project

We wish to confirm that Mr Suresh Balaji Reg No 170292601103 is pursuing final year MBA in B.S
Business Institute of Science and Technology, Chennai has successfully completed the work
as a container logistics trainee in our concern from 15th March 2019 to 20th May 2019.

His performance with us conduct and behaviour was observed to be good. We wish him success in
future.

Ultimate Container Services



Authorized Signature



a **LAVAZZA** Company

TO WHOM IT MAY CONCERN

We are pleased to inform that Mr. Syedfaizal (Reg. No. 170292601104) S/o Mr. Syed Salavudeen, a student of 2nd year at B.S Abdur Rahman Crescent Institute of Science & Technology, Vandalur, Chennai has successfully completed his project as **A Study on Work Life Balance of Lavazza Employees** with duration from 10th March, 2019 to 20th May, 2019. During the period of his project we found his punctual, diligent and sincere.

We wish him the best in his future endeavours.

For Fresh and Honest Café Limited

Name
Designation



Fresh and Honest Café Ltd.

3rd Floor, Hallmark Towers, #35 (SP), Thiruvika Industrial Estate, Guindy, Chennai - 600 032.
Tel.: +91-44-4689 8900 www.lavazza.in, E-mail : info@lavazza.co.in



B.S. Abdur Rahman
Crescent

Institute of Science & Technology
Deemed to be University u/s 3 of the UGC Act, 1956
GST Road, Vandalur, Chennai 600 048

BONAFIDE CERTIFICATE

Certified that this work report is the bonafide work of **P. THOUFIC AHAMUSH(RRN: 105)** who carried out the work under my supervision. Certified further, that to the best of my knowledge the work reported herein does not form part of any other report or dissertation on the basis of which a degree or award was conferred on any earlier occasion on this or any other candidate.

SIGNATURE

DR. S. SRIKANTA SRINIVAS

Assistant Professor

Department of Management Studies

B.S. Abdur Rahman Crescent Institute

Vandalur, Chennai

600 048

SIGNATURE

A. AKHILA

HR

WHITE HOUSE GARMENTS

9, GST main road guduvanchery

Chennai-603202

WHITE HOUSE
No. 6, G.S.T. ROAD,
NANDHIVARAM VILLAGE,
GUDUVANCHERY-603 202.
TIN : 33160520457

SIGNATURE

Dr.M.SANMUGAM

HEAD OF DEPARTMENT

Department of management studies

B.S. Abdur Rahman Crescent Institute of Science & Technology

Vandalur, Chennai – 600 048

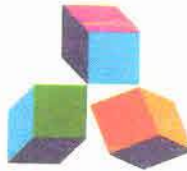

3i Infotech®
LIMITLESS EXCELLENCE

May 21, 2019

TO WHOMSOEVER IT MAY CONCERN

This is to certify that **Ms. Vedavalli S**, a student of Masters in Business Administration (HR), B.S.Abdur Rahman Crescent Institute of science and technology, has completed her Internship in our organization from March 25th, 2019 to May 21st 2019.

She has completed her Internship to our fullest satisfaction. We wish her All the Best in her future endeavors.

For 3i Infotech Ltd,

Sivaraman R,
Sr Associate - HR

3i Infotech Limited

CIN: L67120MH1993PLC074411

T: +91 44 7162 2000 / 2002 W: www.3iinfotech.com

Off Add: Prince Infocity II, 3rd Floor, No.283/4, Rajiv Gandhi Salai (OMR), Kandanchavadi, Chennai - 600 096, India

3rd to 6th Floors, International Infotech Park, Vashi, Navi Mumbai - 400 703, India. T: +91 22 7123 8000 F: +91 22 7123 8310

Date: 14/05/2019

The Director,
MBA Department,
B.S Abdur Rahman Crescent Institute of Science and Technology,
Chennai

Re: Completion of MBA Project

With reference to your letter requesting for a project internship for your student, to ~~Mr. Dinesh R~~ **R (Reg. No: 170292601107)**, completed first year MBA in B.S Abdur Rahman Crescent Institute of Science and Technology, Chennai has successfully completed the finance project titled **"A STUDY ON FINANCIAL PERFORMANCE ANALYSIS"** in our concern from 08/04/2019 to 14/05/2019.

During the tenure with us, conduct & behavior was observed to be good.

Wish success in all the future endeavors.

For Jemi Cluster.

Dinesh R
Team Manager





18/03/2019

ACADEMIC PROJECT CONFIRMATION LETTER

We like to confirm the below student, who is doing final year MBA in B.S Abdul Rahman Crescent Institute of Science and Technology, Chennai has been offered to do the final year academic project in Marketing Department in our concern for a period of 2 months.

STUDENT NAME	REG. NO	SPECIALIZATION
Mr. Vignesh. K	170292601108	Marketing

We wish success in all the future endeavors.

For Autokshi Engineers [P] Ltd,

Karavanathan, A

Authorized Signatory

AUTOKSHI ENGINEERS PRIVATE LIMITED

75, Sengundram Road, Malrosapuram Village, Maraimalainagar, Chennai - 603209

Contact@autokshiengineers.com | Ph: 044- 43322527

TO WHOMSOEVER IT MAY CONCERN

This is to certify that P. Vigneshwari, MBA student of B.S. Abdur Rahman Crescent Institute of Science and Technology, has successfully completed her internship from 15th March 2019 - 10th May 2019 in Graduate Talent program at Virtusa IT Consulting Services Private Limited, Chennai.

- Designation : Intern
- Tier : Tier 5
- Track : Shared Services

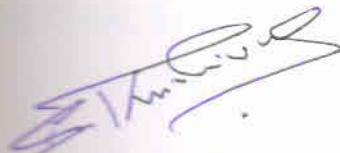

Krithivasan S

Associate Manager- Shared Services



Virtusa Consulting Services Private Limited

Office: 22nd Block DLF IT Park-SEZ, 1/124 Mount Poonamalee Road, Shivaji Garden Moonlight Stop, Nandambakkam Post, Nandambakkam, Chennai - 600 089.

Tel: +91 44 3927 7800 | F: +91 44 3927 7800 | www.virtusa.com

Registered Office: Virtusa Consulting Services Private Limited, Sy. No.115/part, Plot No-10, Nanakramguda Village, Lingampalli Mandal, R.R Dist, Hyderabad - 500032. T: +91 40 44528000

CIN: U72900TG2008FTC057988



B.S. Abdur Rahman

Crescent

Institute of Science & Technology
Deemed to be University u/s 3 of the UGC Act, 1956
GST Road, Vandalur, Chennai 600 048

BONAFIDE CERTIFICATE

that this project report **A STUDY ON WORKING CAPITAL**
IN EBIX SMARTCLASS EDUCATIONAL SERVICES PVT is the bonafide
R AHMAD KHAN (RRN: 170292601110) who carried out the project
y supervision. Certified further, that to the best of my knowledge the work
does not form part of any other project report or dissertation on the
a degree or award was conferred on an earlier occasion on this or any

SIGNATURE

M MUNUSWAMY

Mr. EZHUMALAI

JOINT SUPERVISOR

SR. HR Manager

Institute of Science & Technology

Ebix Smartclass Educational Services

SIGNATURE 27/5/19

DR. SHANMUGAM MUNUSWAMY

Head of the Department

Department of Management Studies

scient Institute of Science & Technology, Vandalur, Chennai – 600 048

**B.S.Abdur Rahman Crescent Institute of Science and
Technology**

Department of Mechanical Engineering

Industrial Visit Report- NLC India Limited



HARNESSING ENERGY
SPREADING SMILES

Mechanical C (III Year)

Class Advisor: Mr. G. RAJESH

ACKNOWLEDGEMENT

The students of Mechanical C (III Year) sincerely thank Dr. S. RasoolMohideen (Dean, School of Mechanical Sciences) and the officials of NLC India Limited who had given us the permission to visit the mines and thermal power plants of NLC India Limited. This visit has helped the students to gain detailed knowledge on the functioning of various activities and machines in the mine and the thermal power station. This would help the students to imply their practical knowledge in future when required.

ABOUT NLC INDIA LIMITED

NLC India Limited (formerly **Neyveli Lignite Corporation Limited**) (NLC) is a 'Navratna' government of India company in the fossil fuel mining sector in India and thermal power generation. It annually produces about 30 million tonne lignite from opencast mines at Neyveli in the state of Tamil Nadu in southern India and at Barsingsar in Bikaner district of Rajasthan state. The lignite is used at pithead thermal power stations of 3240 MW installed capacity to produce electricity. Its joint venture has a 1000 MW thermal power station using coal. Lately it has diversified into renewable energy production and installed 141 MW solar power plant to produce electricity from photovoltaic (PV) cells and 51 MW electricity from windmills.

It was incorporated in 1956 and was wholly owned by the government of India. A small portion of its stock was sold to the public to list its shares on stock exchanges where its shares are traded. It is under the administrative control of Ministry of Coal.



**CREATING WEALTH
FOR WELLBEING**

SHORT HISTORY OF NLC INDIA LIMITED

NLC has been a forerunner in the country in the energy sector for 62 years, contributing a lion's share in lignite production and significant share in thermal power generation. It was inaugurated by the first Prime Minister Jawaharlal Nehru in 1956.

NLC is a Navratna Government of India Enterprise. A pioneer in energy sector, NLC operates four opencast lignite mines of total capacity of 30.6 million tonnes Per Annum (MTPA) at Neyveli and Barsingsar, Rajasthan, Five lignite based pithead Thermal Power Stations with an aggregate capacity of 3240 MW – at Neyveli and Barsingsar and a 1000 MW Coal based Thermal Power Station at Thoothukudi, Tamil Nadu through its subsidiary company, NLC Tamil Nadu Power Limited (NTPL), a joint venture between NLC and TANGEDCO (equity participation in the ratio of 89:11).



NLC has also forayed into renewable energy sector with commissioning of a 141 MW Solar Photo Voltaic Power Plant including 1 MW Roof-top Project at Neyveli and a 51 MW Wind Energy Plant at Kazhuneerkulam Village of Tirunelveli district in Tamilnadu. The Company is also setting up 1209 MW Solar Power Projects at Tirunelveli, Virudhunagar and Ramanathapuram districts of Tamil Nadu, of which, 300 MW have been commissioned. NLC is aiming to achieve a total Renewable energy capacity of 4251 MW.



NLC has big dreams to become a 20000+ MW company by 2025. Towards realising this dream, NLC is already on expansion mode. Works are under progress for the Lignite based Neyveli New Thermal Power Plant (1000 MW), Bithnok TPS and Barsingsar TPS Expansion (each 250 MW). Further, NLC, jointly with the Uttar Pradesh RajyaVidyutUtpadan Nigam Limited (UPRVUNL), is setting up a 3x660 MW Coal based Thermal Power Plant at Ghatampur in Uttar Pradesh, through its subsidiary company Neyveli Uttar Pradesh Power Limited (NUPPL) (equity participation in the ratio of 51:49). Apart from the above, addition of Thermal Capacity to the tune of 6040 MW by way of installation of new plants and acquisition of Power Assets to the tune of 3000 MW is in the pipeline.



DETAILS OF THE INDUSTRIAL VISIT

Our journey to NLC India Limited began at 5:30 a.m. on 01.10.2018 from our campus. We were accompanied by our staff **Mr. G. RAJESH**, Assistant Professor & Class Advisor and **Mr. M. BALASRINIVASAN**, Assistant Professor. The primary aim of this industrial visit was to gain practical knowledge about the functioning of mines and thermal power plants.

As our syllabi had topics related to power generation, this visit was very fruitful for us.

Lignite, often referred to as brown coal, is a soft, brown, combustible, sedimentary rock formed from naturally compressed peat. It is considered the lowest rank of coal due to its relatively low heat content. It has a carbon content around 60–70 percent.





We reached our location at 10:30 am and made our first visit to the Mine 1. An official of the NLC helped the students by being our guide for the day and cleared our doubts. The mine here was open cast mine with an area of 7 sq. km. The average life of an open cast mine of this area is estimated to be 60 years. Such a mine can be dug up to a maximum depth of 750 feet.



MINE 1- NLC INDIA LIMITED

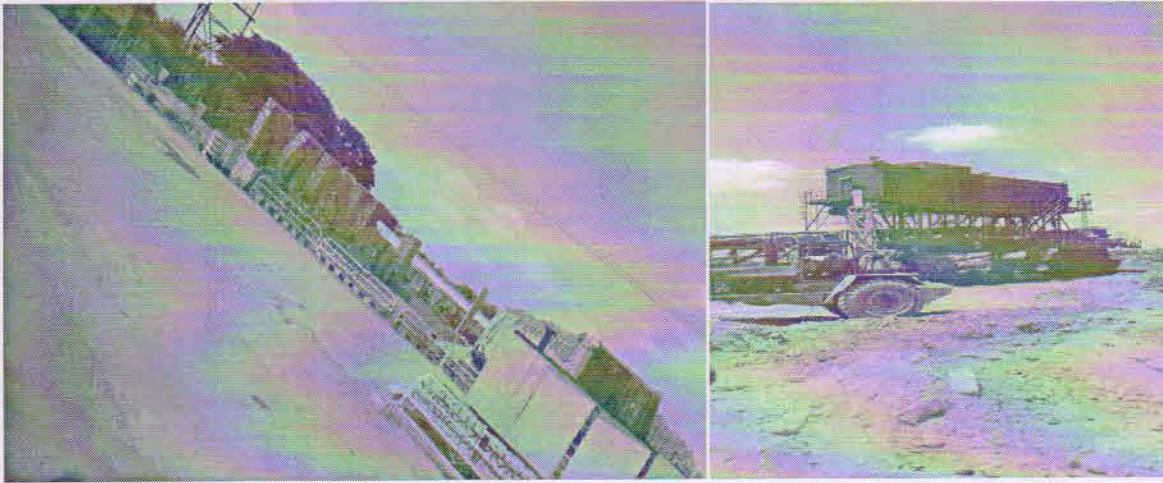

The lignite collected from the mine is transferred to the bunker through the conveyor for the purpose of storage. This stored lignite is used to meet the future requirements.



TRANSPORTING LIGNITE THROUGH CONVEYORS AND TRUCKS

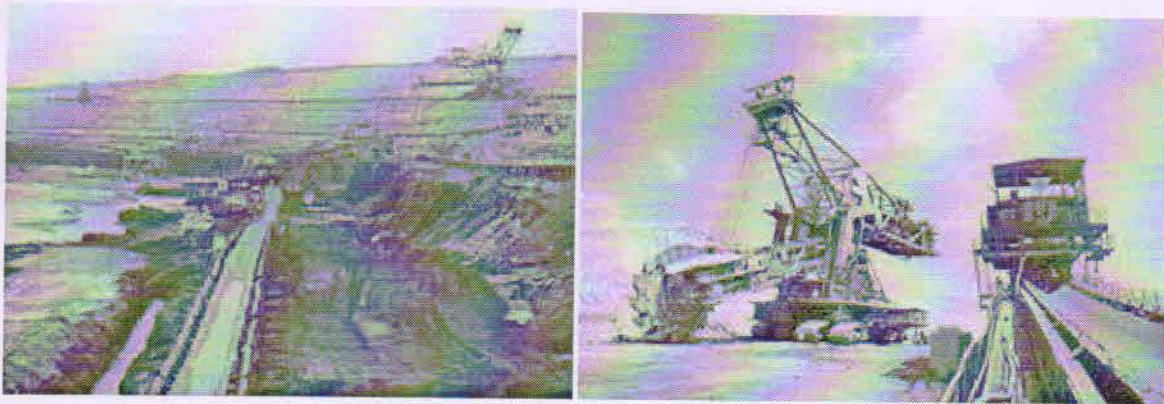

Shortly later, our travel continued to the Thermal Power Plant 1 where we got the opportunity to witness and learn about the functioning of the power station and their humongous equipment.

The Thermal Power Station began its operation from 1957 and since then, 6 power plants have been constructed. Each power plant produces approximately 600 MW of electricity.

The power station consists of boiler, turbine, generator, condenser and exhaust. The boiler is 90 m high.



The cooling towers were the prominent structures which are 118 m high which uses zig-zag arrangement of tubes for the purpose of cooling the water using normal air.

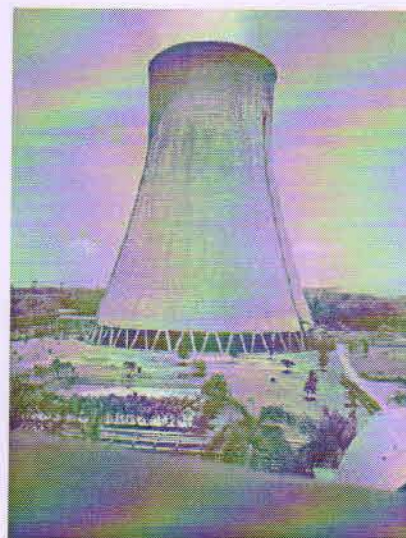

To prevent dust accumulation in the power plant, ESP (Electro Static Principle) is set at 96.4.

The chimney has a height of 260 m. The dry ash obtained as a waste product is used to make cement thus recycling the waste products into a usable material.



BIBLIOGRAPHY

1. https://en.wikipedia.org/wiki/NLC_India_Limited

2. <https://www.nlcindia.com>

(G. Rajesh)

**B.S.Abdur Rahman Crescent Institute of Science and
Technology**

Department of Mechanical Engineering

Industrial Visit Report- Ashok Leyland, Ennore



Ashok Leyland

Mechanical B (II Year)

Class Advisor: Mr. A. MUTHU MANOKAR



B.S. Abdur Rahman

Crescent

Institute of Science & Technology
Deemed to be University u/s 3 of the UGC Act, 1956

I. Preamble:

“Class room learning and industry learning are like apples and oranges. They both are fruits, but taste completely different”

Industrial visit is considered as one of the tactical methods of teaching. The main reason behind this it allows the student to know things practically through interaction, working methods and employment practices. Moreover, it gives exposure from academic point of view. Main aim of industrial visit is to provide an exposure to students about practical working environment. It also provides a good opportunity for the students to gain full awareness about industrial practices. Through industrial visit students get awareness about new technologies. Technology development is a main factor, about which a students should have a good knowledge. Visiting different companies actually help students to build a good relationship with those companies. We know building relationship with companies always will always help to gain a good job in future. After visiting an industry students can gain a combined knowledge about both theory and practical. Students will be more concerned about earning a job after having an industrial visit.

II. About the visit

On 03rd April, 2018 Students of II Year Mechanical Section- B (62 Nos) with two faculty members visited the *Ashok Leyland industry, Ennore*. The following are the list of students participated in the industrial visit:

Sl. No.	Name of the student	RRN
1	ASHFAAQ KK	170021601055
2	HUSSAIN KHAN.A	170021601056
3	LAZIM RASHEED	170021601057
4	MARUDHUPANDIAN.M	170021601058
5	MASILA RAHUL	170021601059
6	MASIUDDIN. P.S	170021601060
7	MIYA RASHEED AHMED HISSAN	170021601061
8	MOHAMED AFFAN V.	170021601062
9	MOHAMED ARSALAN.B	170021601063
10	MOHAMED ARSATH A	170021601064
11	MOHAMED ASHFAQ AHMED A B	170021601066
12	MOHAMED FAYZ H	170021601067
13	MOHAMED IMTHIYAS R.	170021601068
14	MOHAMED IRFAN.S	170021601069
15	MOHAMED JISHAAN H.	170021601070
16	MOHAMED MUKTHAR	170021601071
17	MOHAMED RAZEEN .A	170021601072
18	MOHAMED RIYAZ KHAN. M	170021601073
19	MOHAMED SABIK.M	170021601074
20	MOHAMED SAFEER.S	170021601075
21	MOHAMED SHAMEER M	170021601076
22	MOHAMED SUHAIB ABDULLAH	170021601077

23	MOHAMED THALIB M	170021601078
24	MOHAMED THARIK M	170021601079
25	MOHAMED YOUSUF	170021601080
26	MOHAMED ZAVID. A.G	170021601081
27	MOHAMMED AASHIQ.M	170021601082
28	MOHAMMED ASLAM H.	170021601084
29	MOHAMMED HAAREES KHAN N	170021601085
30	MOHAMMED MOHSIN M	170021601086
31	MOHAMMED NAUFAL A	170021601087
32	MOHAMMED SAHAL V	170021601088
33	MOHAMMED SHUAIB. B	170021601090
34	MOHAMMED THOUFEEQ M	170021601091
35	MOHAMMED ZUBAIR FATHAI S	170021601092
36	MOHAMMED IBRAHIM F	170021601093
37	MOHAN RAJ R.	170021601094
38	MOOLAI AFNAN ZAID	170021601095
39	MUGESH. P	170021601096
40	MURALIKRISHNAN D	170021601097
41	MUSHAD.M	170021601098
42	NATHERATHAM A	170021601099
43	NICHENAMETLA HEMANTH KUMAR	170021601100
44	NIYAS AHAMED A	170021601101
45	PATTUPOGULA SEENU	170021601102
46	PRADEEP KRISHNA R	170021601103
47	SHUAIB AHAMED H.R.	170021601105
48	SYED ASHHAD AFNAN	170021601106
49	RAGUL ESWAR	170021601162

50	MUHAMED ZAYAN	170021601163
51	KAREEMULLA. S	170021601167
52	ALI AHAMED H	170021601168

Mr. A. Muthu Manokar, Assistant Professor and Mr. D.R. Rajendran, Assistant Professor accompanied the following students during the industrial visit.



Fig.1 Students in front of Ashok Leyland factory

The objective of the visit is to understand about the industrial practices and also to combine the theoretical knowledge with practical knowledge through field observation, inquiry and submission of relevant report.

The students were divided into 2 batches, the first batch visited the UNIT 1 and other batch visited the UNIT 2 of Ashok Leyland. And the batches were interchanged afterwards. Students were able to view the assembly line where the engine is being assembled.



Fig.2 Engine assembly section

It was helpful to learn about the assembly of the engine and engine block of the HICO engine, NISSAN ZD350 engine. The manufacturing of the engine cylinder block and cylinder head is done in the machine laboratory using CNC and then assembled in the assembly laboratory. The students learnt about the materials used for the cylinder head and block head i.e. aluminum and cast iron and also regarding the procedures involved. The coordinators explained each and every process that takes place.

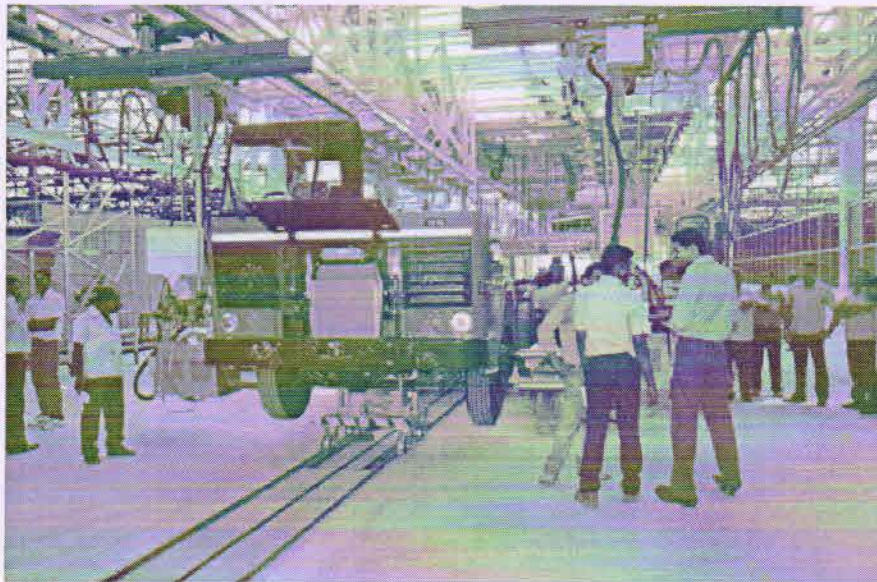

Fig.3 Truck vehicle assembly section

Outcome of this Industrial Visit:

- Fantastic experience to industrial atmosphere.
- Able to familiarize with the modern technology being used in their company.
- Types of vehicles being produced in their company.
- How a company manages huge productivity.

Note: Students were also encouraged to submit a detailed report on functioning of various processes/systems at Ashok Leyland, Ennore to augment their understanding skills.

A. Muthu Manokan

(A. MUTHU MANOKAN)

**B.S.Abdur Rahman Crescent Institute of Science and
Technology**

Department of Mechanical Engineering

Industrial Visit Report- NLC India Limited



Mechanical D (IV Year)

Class Advisor: Mr. N. RAVIKUMAR

ACKNOWLEDGEMENT

The students of Mechanical C (III Year) sincerely thank Dr. S. RasoolMohideen (Dean, School of Mechanical Sciences) and the officials of NLC India Limited who had given us the permission to visit the mines and thermal power plants of NLC India Limited. This visit has helped the students to gain detailed knowledge on the functioning of various activities and machines in the mine and the thermal power station. This would help the students to imply their practical knowledge in future when required.

ABOUT NLC INDIA LIMITED

NLC India Limited (formerly **Neyveli Lignite Corporation Limited**) (NLC) is a 'Navratna' government of India company in the fossil fuel mining sector in India and thermal power generation. It annually produces about 30 million tonne lignite from opencast mines at Neyveli in the state of Tamil Nadu in southern India and at Barsingsar in Bikaner district of Rajasthan state. The lignite is used at pithead thermal power stations of 3240 MW installed capacity to produce electricity. Its joint venture has a 1000 MW thermal power station using coal. Lately it has diversified into renewable energy production and installed 141 MW solar power plant to produce electricity from photovoltaic (PV) cells and 51 MW electricity from windmills.

It was incorporated in 1956 and was wholly owned by the government of India. A small portion of its stock was sold to the public to list its shares on stock exchanges where its shares are traded. It is under the administrative control of Ministry of Coal.



**CREATING WEALTH
FOR WELLBEING**

SHORT HISTORY OF NLC INDIA LIMITED

NLC has been a forerunner in the country in the energy sector for 62 years, contributing a lion's share in lignite production and significant share in thermal power generation. It was inaugurated by the first Prime Minister Jawaharlal Nehru in 1956.

NLC is a Navratna Government of India Enterprise. A pioneer in energy sector, NLC operates four opencast lignite mines of total capacity of 30.6 million tonnes Per Annum (MTPA) at Neyveli and Barsingsar, Rajasthan, Five lignite based pithead Thermal Power Stations with an aggregate capacity of 3240 MW – at Neyveli and Barsingsar and a 1000 MW Coal based Thermal Power Station at Thoothukudi, Tamil Nadu through its subsidiary company, NLC Tamil Nadu Power Limited (NTPL), a joint venture between NLC and TANGEDCO (equity participation in the ratio of 89:11).



NLC has also forayed into renewable energy sector with commissioning of a 141 MW Solar Photo Voltaic Power Plant including 1 MW Roof-top Project at Neyveli and a 51 MW Wind Energy Plant at Kazhuneerkulam Village of Tirunelveli district in Tamilnadu. The Company is also setting up 1209 MW Solar Power Projects at Tirunelveli, Virudhunagar and Ramanathapuram districts of Tamil Nadu, of which, 300 MW have been commissioned. NLC is aiming to achieve a total Renewable energy capacity of 4251 MW.



NLC has big dreams to become a 20000+ MW company by 2025. Towards realising this dream, NLC is already on expansion mode. Works are under progress for the Lignite based Neyveli New Thermal Power Plant (1000 MW), Bithnok TPS and Barsingsar TPS Expansion (each 250 MW). Further, NLC, jointly with the Uttar Pradesh RajyaVidyutUtpadan Nigam Limited (UPRVUNL), is setting up a 3x660 MW Coal based Thermal Power Plant at Ghatampur in Uttar Pradesh, through its subsidiary company Neyveli Uttar Pradesh Power Limited (NUPPL) (equity participation in the ratio of 51:49). Apart from the above, addition of Thermal Capacity to the tune of 6040 MW by way of installation of new plants and acquisition of Power Assets to the tune of 3000 MW is in the pipeline.



DETAILS OF THE INDUSTRIAL VISIT

Our journey to NLC India Limited began at 5:30 a.m. on 03.08.2018 from our campus. We were accompanied by our staff **Mr. N. RAVI KUMAR**, Assistant Professor & Class Advisor and **Mr. B. SIVAKUMAR**, Assistant Professor. The primary aim of this industrial visit was to gain practical knowledge about the functioning of mines and thermal power plants.

As our syllabi had topics related to power generation, this visit was very fruitful for us.

Lignite, often referred to as brown coal, is a soft, brown, combustible, sedimentary rock formed from naturally compressed peat. It is considered the lowest rank of coal due to its relatively low heat content. It has a carbon content around 60–70 percent.



Students in front of the plant

We reached our location at 10:30 am and made our first visit to the Mine 1. An official of the NLC helped the students by being our guide for the day and cleared our doubts. The mine here was open cast mine with an area of 7 sq. km. The average life of an open cast mine of this area is estimated to be 60 years. Such a mine can be dug up to a maximum depth of 750 feet.



MINE 1- NLC INDIA LIMITED



The lignite collected from the mine is transferred to the bunker through the conveyor for the purpose of storage. This stored lignite is used to meet the future requirements.



TRANSPORTING LIGNITE THROUGH CONVEYORS AND TRUCKS

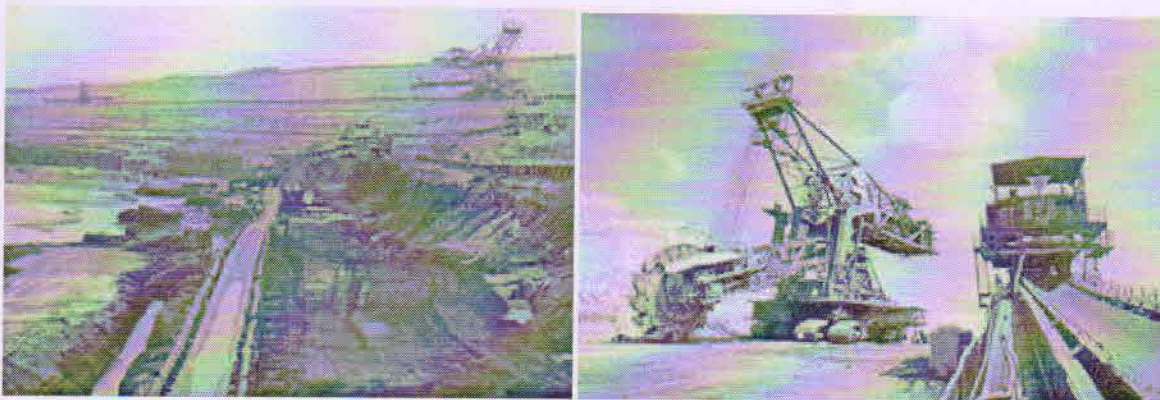

Shortly later, our travel continued to the Thermal Power Plant 1 where we got the opportunity to witness and learn about the functioning of the power station and their humongous equipment.

The Thermal Power Station began its operation from 1957 and since then, 6 power plants have been constructed. Each power plant produces approximately 600 MW of electricity.

The power station consists of boiler, turbine, generator, condenser and exhaust. The boiler is 90 m high.



The cooling towers were the prominent structures which are 118 m high which uses zig-zag arrangement of tubes for the purpose of cooling the water using normal air.

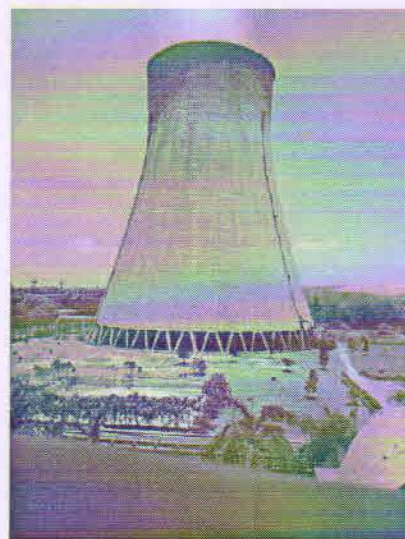

To prevent dust accumulation in the power plant, ESP (Electro Static Principle) is set at 96.4.

The chimney has a height of 260 m. The dry ash obtained as a waste product is used to make cement thus recycling the waste products into a usable material.

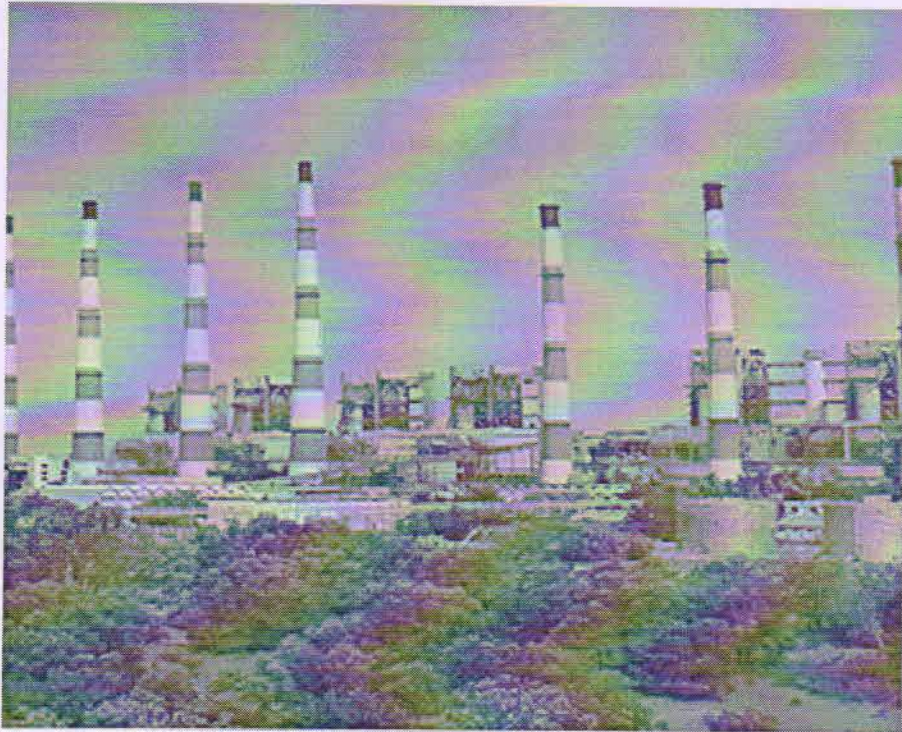

BIBLIOGRAPHY

1. https://en.wikipedia.org/wiki/NLC_India_Limited

2. <https://www.nlcindia.com>

N. Raju
(N. Raju)

**B.S.Abdur Rahman Crescent Institute of Science and
Technology**

Department of Mechanical Engineering

Industrial Visit Report- Ashok Leyland, Ennore



Ashok Leyland

Mechanical A (III Year)

Class Advisor: Mr. K. Jamesha Ibrahim



B.S. Abdur Rahman

Crescent

Institute of Science & Technology
Deemed to be University u/s 3 of the UGC Act, 1956

I. Preamble:

“Class room learning and industry learning are like apples and oranges. They both are fruits, but taste completely different”

Industrial visit is considered as one of the tactical methods of teaching. The main reason behind this it allows the student to know things practically through interaction, working methods and employment practices. Moreover, it gives exposure from academic point of view. Main aim of industrial visit is to provide an exposure to students about practical working environment. It also provides a good opportunity for the students to gain full awareness about industrial practices. Through industrial visit students get awareness about new technologies. Technology development is a main factor, about which a students should have a good knowledge. Visiting different companies actually help students to build a good relationship with those companies. We know building relationship with companies always will always help to gain a good job in future. After visiting an industry students can gain a combined knowledge about both theory and practical. Students will be more concerned about earning a job after having an industrial visit.

II. About the visit

On 03rd August, 2018 Students of III Year Mechanical Section- A (52 Nos) with two faculty members visited the *Ashok Leyland industry, Ennore*. The following are the list of students participated in the industrial visit:

Sl. No.	Name of the student	RRN
1	AADHISHESHA PANDI S	160021601001
2	AAKASH RAM. S.	160021601002
3	AAKASH S	160021601003
4	AASHIEK.N	160021601004
5	ABDUL AZEEM S	160021601005
6	ABDUL KALAAM M D	160021601007
7	ABDUL KHALITH K	160021601008
8	ABDUL MALIK A	160021601009
9	ABDULLAH M	160021601010
10	ABRAR KHAN A	160021601011
11	ABUBUCKER SIDDIQ.M	160021601013
12	ABUDHAHIR G	160021601014
13	ABUSAR M	160021601015
14	ABUSHEIK B	160021601016
15	ACHULA TARUN PHANINDRA KUMAR	160021601017
16	AFRAR AHMED N	160021601018
17	AHAMED M	160021601019
18	AHAMED YUSUF ANSARY M	160021601020
19	AKASH P	160021601021
20	AKHIL RAHMAN K	160021601022
21	AKHIL REHUMAN R	160021601023
22	AMEENUL HASAN A	160021601025
23	ANAS MOHAMMED J	160021601026
24	ARAVINDH KUMAR SSR	160021601027
25	ARON MIJI	160021601029
26	ARSHAD SHAIK	160021601030
27	ARSHATH AHAMED	160021601031
28	ARUL ABRAGHAM J E	160021601032
29	ASHIK ALI A	160021601033
30	ASHWANTH KUMAR J	160021601034

Sl. No.	Name of the student	RRN
31	BALACHANDAR R	160021601036
32	BALAJI H	160021601037
33	BARATHSRE R	160021601038
34	BHARANI BALLAJE M	160021601039
35	DHINESH M	160021601040
36	DINESH KANNAN R	160021601041
37	ENAYATHULLA S	160021601042
38	EZHIL NAVEENAN E L	160021601043
39	EZHILVEL	160021601044
40	FAHDHIL OMER QATHAB	160021601045
41	FAIZAL K	160021601046
42	FAROOQ AFZAL KHAN A	160021601047
43	GANESH T	160021601048
44	GIRI VIGNESH	160021601049
45	GOKUL PRASATH S	160021601051
46	HAMEEM HASAN K	160021601052
47	HANEEF MOHAMED S	160021601053
48	HARIHARAN	160021601054
49	HARIRAM M	160021601055
50	ATHITRAJ M.A.	160021601209
51	ANBUPRAVIN I.	160021602001
52	ARIS AHMED A.	160021602002

Dr. M. Thirumurugan, Associate Professor and Mr. K. Jamesha Ibrahim, Assistant Professor accompanied the following students during the industrial visit.

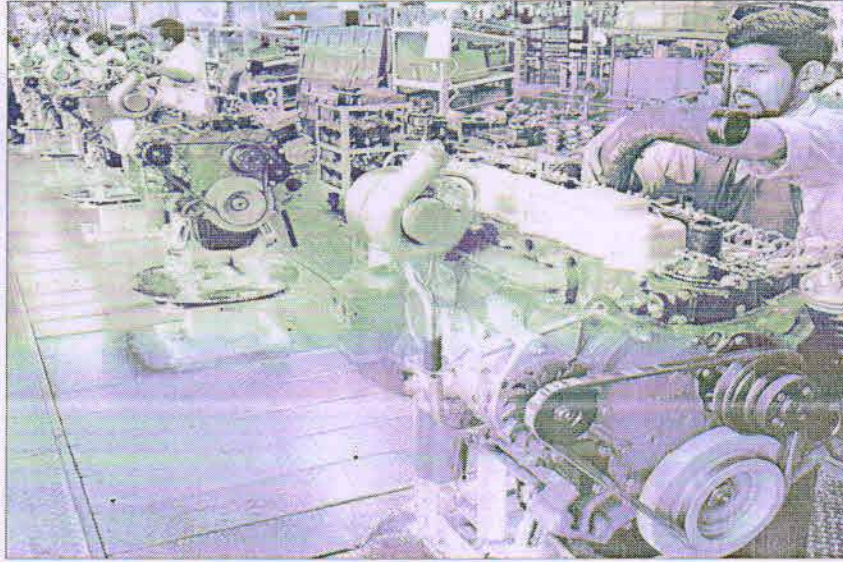

Fig.2 Engine assembly section

It was helpful to learn about the assembly of the engine and engine block of the HICO engine, NISSAN ZD350 engine. The manufacturing of the engine cylinder block and cylinder head is done in the machine laboratory using CNC and then assembled in the assembly laboratory. The students learnt about the materials used for the cylinder head and block head i.e. aluminum and cast iron and also regarding the procedures involved. The coordinators explained each and every process that takes place.

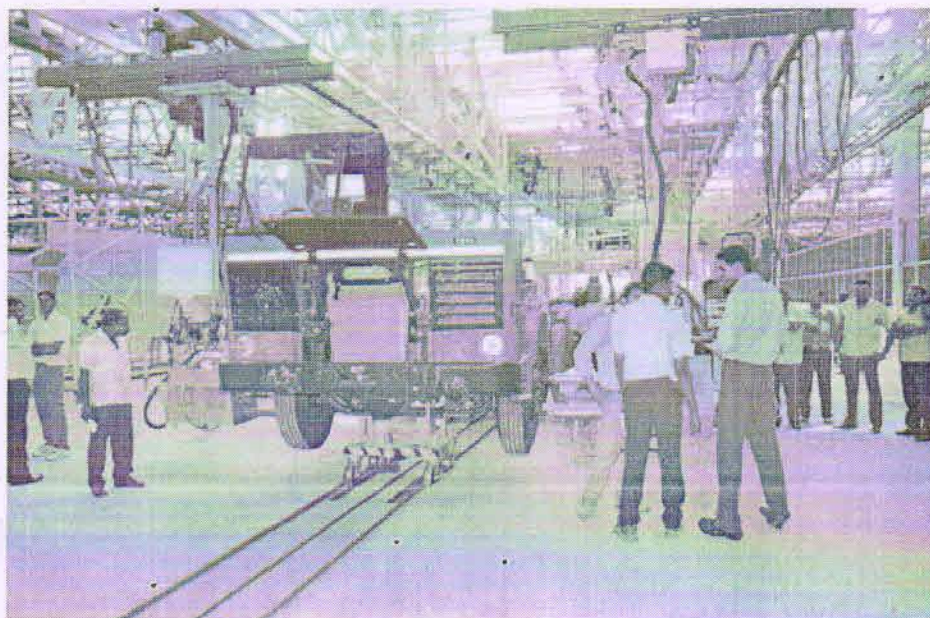

Fig.3 Truck vehicle assembly section



Fig.1 Students in front of Ashok Leyland factory

The objective of the visit is to understand about the industrial practices and also to combine the theoretical knowledge with practical knowledge through field observation, inquiry and submission of relevant report.

The students were divided into 2 batches, the first batch visited the UNIT 1 and other batch visited the UNIT 2 of Ashok Leyland. And the batches were interchanged afterwards. Students were able to view the assembly line where the engine is being assembled.

Outcome of this Industrial Visit:

- Fantastic experience to industrial atmosphere.
- Able to familiarize with the modern technology being used in their company.
- Types of vehicles being produced in their company.
- How a company manages huge productivity.

Note: Students were also encouraged to submit a detailed report on functioning of various processes/systems at Ashok Leyland, Ennore to augment their understanding skills.

M. Mithi Suresh
25/10/19
(M. Mithi Suresh)

INSIGHT LEARNING IN INDUSTRY

ASHOK LEYLAND, HOSUR

Year: 2017-2018 Batch: B. Tech (2016-2020)

Date: 23.03.2018

No. of students: 55

No. of faculty members: 2

Organized by

Department of Mechanical Engineering

BSACIST, Vandalur, Chennai-48.

Learning is the only thing the mind never exhausts, never fears, and never regrets
Learning is the only thing the mind never exhausts, never fears, and never regrets
-Leonardo Da Vinci

DEAN (ACADEMIC AFFAIRS)
B.S. Abdur Rahman Crescent
Institute of Science & Technology
Vandalur, Chennai - 600 048.



B.S. Abdur Rahman
Crescent

Institute of Science & Technology
Deemed to be University w/s 3 of the UGC Act, 1956

REPORT ON INSIGHT OF INDUSTRY

ASHOK LEYLAND, HOSUR

I. Preamble:

“Class room learning and industry learning are like apples and oranges. They both are fruits, but taste completely different”

Industrial visit is considered as one of the tactical methods of teaching. The main reason behind this it allows the student to know things practically through interaction, working methods and employment practices. Moreover, it gives exposure from academic point of view. Main aim of industrial visit is to provide an exposure to students about practical working environment. It also provides a good opportunity for the students to gain full awareness about industrial practices. Through industrial visit students get awareness about new technologies. Technology development is a main factor, about which a students should have a good knowledge. Visiting different companies actually help students to build a good relationship with those companies. We know building relationship with companies always will always help to gain a good job in future. After visiting an industry students can gain a combined knowledge about both theory and practical. Students will be more concerned about earning a job after having an industrial visit.

II. About the visit

On **23rd March, 2018** Students of **III Year Mechanical Section- D** (55 Nos) with two faculty members visited the **Ashok Leyland industry, Hosur**. The following are the list of students participated in the industrial visit:

DEAN (ACADEMIC AFFAIRS)
B.S. Abdur Rahman Crescent
Institute of Science & Technology
Vandalur, Chennai - 600 048.

S. No	RRN Number	Name
1	140021601046	FEROZ AHAMED. B.M.
2	140021601220	VIGNESH PAVITHRAN R
3	150021601146	RANJAN S
4	150021601147	RANJETH KUMAR T
5	150021601148	REVANTHRAJ J
6	150021601149	RISHAD AHAMED S
7	150021601150	ROASHAN N T
8	150021601151	SAMSUL HAK M
9	150021601153	SATHISH KUMAR R
10	150021601154	SEYED IBRAHIM M A K
11	150021601155	SHAFITH MOHAMMED Y
12	150021601156	SHAHEED AHAMED ISMAIL S
13	150021601157	SHAIK REHAMAN
14	150021601158	SHAILESH R N
15	150021601159	SHEIK HUSSAIN M
16	150021601160	SHRINIVASAN S
17	150021601161	SHYAM SUNDAR A
18	150021601162	SRI RAM
19	150021601163	SRIDHARAN. M
20	150021601164	SRIHARI K
21	150021601165	SRIRAM SURYA N
22	150021601166	SUDHAN P
23	150021601167	SUHAIL AHMED A
24	150021601168	SURIYA NAMBISAN J P
25	150021601169	SYED ABDUL AZEEZ
26	150021601170	SYED ANWER H
27	150021601172	SYED MOHAMMAD SALMAN H
28	150021601173	SYED SHAHEER S
29	150021601174	TANSEER AHMED K
30	150021601175	TAREESH ANAND S
31	150021601177	UDITH RAKHAV A S
32	150021601178	UVAISH AHAMED N
33	150021601179	VIGNESH KUMAR B
34	150021601180	VIGNESHWAR M
35	150021601181	VIGNESWAR R
36	150021601183	VIJAY VIGNESHWAR G
37	150021601184	VISHNU M

S. No	RRN Number	Name
38	150021601185	WASEEM AHMED A
39	150021601187	YASER T
40	150021601188	YASHAR ARABATH A
41	150021601194	GOKULAN H
42	150021601195	KARTHIK V
43	150021601196	MOHAMMED ABDUL RAFAY
44	150021601197	MOHAMMED MUZAMMIL A
45	150021601198	ROGANKUMAR S
46	150021601199	ROHIT KUMAR S
47	150021601200	SHAKIR AHMED SULTHAN A
48	150021601219	MOHAMMED KASSIM R
49	150021601222	THIRUVABAVAN R
50	150021601223	VIGNESH V
51	150021601232	MOHAMED AFRAD B
52	150021601233	GEETHA M
53	150021601235	MANGALNATH A
54	150021602011	NASEERUL HAZWAN M
55	150021602012	VINOD KUMAR P

Mr. K. Jamesha Ibrahim, Assistant Professor and Mr. R. Varun Kumar, Assistant Professor accompanied the following students during the industrial visit.

The objective of the visit is to understand about the industrial practices and also to combine the theoretical knowledge with practical knowledge through field observation, inquiry and submission of relevant report.

The students were divided into 2 batches, the first batch visited the UNIT 1 and other batch visited the UNIT 2 of Ashok Leyland. And the batches were interchanged afterwards. Students were able to view the assembly line where the engine is being assembled.

DEAN (ACADEMIC AFFAIRS)
 B.S. Abdur Rahman Crescent
 Institute of Science & Technology
 Vandalur, Chennai - 600 048.



Fig.1 Students in front of Ashok Leyland factory



Fig.2 Engine assembly section

It was helpful to learn about the assembly of the engine and engine block of the HICO engine, NISSAN ZD350 engine. The manufacturing of the engine cylinder block and cylinder head is done in the machine laboratory using CNC and then assembled in the assembly laboratory. The students learnt about the materials used for the cylinder head and block head

i.e. aluminum and cast iron and also regarding the procedures involved. The coordinators explained each and every process that takes place.



Fig.3 Truck vehicle assembly section



Fig.4 Batch 2 @ Plant II

A. Mani
DEAN (ACADEMIC AFFAIRS)
B.S. Abdur Rahman Crescent
Institute of Science & Technology
Vandalur, Chennai - 600 048.

Outcome of this Industrial Visit:

- Fantastic experience to industrial atmosphere.
- Able to familiarize with the modern technology being used in their company.
- Types of vehicles being produced in their company.
- How a company manages huge productivity.

Note: Students were also encouraged to submit a detailed report on functioning of various processes/systems at Ashok Leyland, Hosur to augment their understanding skills.

Staff Co-ordinator



Dean/SMS
DEAN
School of Mechanical Science
B.S. Abdur Rahmar
Crescent
Institute of Science & Technology
Vandalur, Chennai-600 048.

DEAN (ACADEMIC AFFAIRS)
B.S. Abdur Rahman Crescent
Institute of Science & Technology
Vandalur, Chennai - 600 048.

Report of Industrial Visit

Session 2019-19

**B. Com. General, B. Com. (A&F) and BBA (Financial Services)
I Year and II Year**

Dates of the Visit

05.03.2019	:	B.Com. General, II Year, Section A B.Com. A&F, II Year, Section A,
13.03.2019	:	B.Com. General, I Year, Section A, B and D
14.03.2019	:	B.Com. General, I Year, Section C and E B.Com. A&F, I Year, Section A and B
11.04.2019	:	B.Com. General, II Year, Section B, C and D BBA Financial Services I Year, Section A

Department of Commerce

**B. S. Abdurrahman Crescent Institute of Science & Technology
Chennai - 600048**

I. Art and Sculpture Work with Commerce perspective: An Industrial Visit to Mahabalipuram (05.03.2019)

1. Preamble

Industrial visit has its own importance in a career of a student who is pursuing a professional degree. It is considered as a part of college curriculum and objectives of industrial visit is to provide students an insight regarding internal working of companies. We know, theoretical knowledge is not enough for making a good professional career. With an aim to go beyond academics, industrial visit provides student a practical perspective on the world of work. Following the same lines students of B.Com General and A &F got an opportunity to visit the art and Sculpture work at Mahabalipuram.

2. List of the Name of Participants

2.1 List of the Name of Students (93 Students)

B. Com. General 'A' IV Semester

S.No	Name of the Students	RRN
1	Abdul Hassan S	171291601001
2	Abdul Jabbar A	171291601002
3	Abdul Jasim M	171291601003
4	Abdul Kalam Azad J	171291601004
5	Abdul Rahman J	171291601005
6	Abdul Salik I	171291601006
7	Abdul Wahith A	171291601007
8	Abinaya V	171291601008
9	Abinaya T S	171291601009
10	Afrin Fathima M	171291601010
11	Afrin Fathima S	171291601011
12	Ahamed Arish S	171291601012
13	Ahamed Rasith P	171291601013
14	Ajay Kumar P	171291601014
15	Ajith Kumar K	171291601015
16	Akash S	171291601016
17	Akbar Basha M	171291601017
18	Akram T	171291601018
19	Anish Ahamed S	171291601019
20	Anushya A	171291601020

21	Ashwini G	171291601021
22	Aswin D	171291601022
23	Barath K	171291601023
24	Barath Kumar B	171291601024
25	Benny A	171291601025
26	Bharath B	171291601026
27	Barath S	171291601027
28	Bharathi P	171291601028
29	Bhuvana K	171291601029
30	Buganesh S	171291601030
31	Chakla Mohammed Karrim S	171291601031
32	Christena T	171291601032
33	Collins Deva Prasad G	171291601033
34	Deepak R	171291601034
35	Deepak Raj D	171291601035
36	Deepak Vishal K	171291601036
37	Devarajan K	171291601037
38	Dhinesh S	171291601038
39	Dinesh Kumar R N	171291601039
40	Divya Preetha G	171291601040
41	Divya V	171291601041
42	Elangovan. G	171291601042
43	Faratheba P	171291601043
44	Fathariya Begam S	171291601044
45	Fathima Rizwana M	171291601045
46	Girish Prabhu P	171291601046
47	Gnana Prasath P	171291601047
48	Gokula Kumar R	171291601048
49	Gomathi M	171291601049
50	Gomathy Kannan	171291601050
51	Hameed Abdul Rahman S	171291601051
52	Harikrishnan R	171291601052
53	Harini K	171291601053

B. Com. A&F 'A' IV Sem.

1	Abdul Mughni. K.A	171411601001
2	Abdul Wahab. B.S	171411601002
3	Afreen Begum. S	171411601003
4	Afrin Fathima. S.A	171411601004
5	Anisha Beevi. M	171411601005
6	Anusha. R	171411601006
7	Athif Olakara	171411601007



8	Aziz Muffadal Madarwala	171411601008
9	Balamuruganathan. S	171411601009
10	Bharani. M	171411601010
11	Divya. S	171411601011
12	Eswar. V.N	171411601012
13	Farhath Nazia. K	171411601013
14	Gokul. R	171411601014
15	Gopinath. N	171411601015
16	Hemaverthenee. C	171411601016
17	Jaganath. SP	171411601017
18	Jalal Fazal Kareem	171411601018
19	Madhumitha. G	171411601019
20	Mohammed Arif. A.H	171411601020
21	Mohammed Fayaz. K	171411601021
22	Mohammed Fazal. K	171411601022
23	Muhammed Sahal	171411601023
24	Naveen. V	171411601024
25	Parveen. A	171411601025
26	Preethi. E	171411601026
27	Preethi. S	171411601027
28	Reda Rafat	171411601028
29	Robert. A	171411601029
30	Sarathkumar. Y	171411601030
31	Sheeba. S	171411601031
32	Sindhu. V.G	171411601032
33	Srinidhi. S	171411601033
34	Suhail Mohammed. M	171411601034
35	Swetha. S	171411601035
36	Syed Abu Thahir. S	171411601036
37	Unes. J	171411601037
38	Vasist Vignesh. V	171411601038
39	Vishnu Priyan. P	171411601040
40	Yasodaha. A	171411601041
41	Gowtham. P	171411601042
42	Swetha. A	171411601043

S.No.	Name of the faculty Members	Designation
1	Dr. Nirmala S	Assistant Professor
2	Dr. Sibghatullah Nasir	Assistant Professor
3	Dr. Murali	Assistant Professor
4	Dr. Rathika Meghanathan	Assistant Professor
5	Dr. Srinivasan P	Assistant Professor

3. Salient Features of the Industrial Visit

3.1 Mahabalipuram: A Place of Rock and Stone Sculpture

Mahabalipuram or Mamallapuram is an ancient port city in the Kancheepuram district of Tamil Nadu. Once a bustling seaport and a busy trading centre, the place is now one of the major tourist attractions near Chennai. Mahabalipuram has a rich history and heritage that is well-preserved to date and speaks volumes of its glory. Mahabalipuram is one of the oldest cities in India. Present day, it is known for its great monuments, cave sanctuaries and sculptures. A monument complex at Mahabalipuram, known as the Group of Monuments, with all its rock art and relief sculptures, is a UNESCO world site.



Fig-1: A beautiful day to start the industrial visit in Mahabalipuram

The famous Pancha Rathas (also known as Pandava Rathas) (late 7th century) is an example of monolithic Indian rock-cut architecture. Each of the five monuments in the Pancha Rathas complex resembles a chariot (ratha), and each is carved over a single, long stone or monolith, of granite which slopes in north-south direction with a slight incline

It is a sculpture town, and on either side of the roads one would find display of sculptures and paintings. The numerous temples and rock carvings are classic examples of South Indian temple art and its evolution during the reign of the Pallava kings. The town not only has a beautiful beach, a British era Light-house, but numerous interesting rock formations as well. The place is still the centre of stone carving.

3.2 Government College of Architecture and Sculpture, Mamallapuram

The Government College of Architecture and Sculpture was established in Mamallapuram in 1957. Four-Year Degree Courses are offered in this College from 2000-2001. B.Tech in Traditional Architecture, B.F.A in Traditional Sculpture and B.F.A in Traditional Drawing and Painting are offered. Considering the Development of this Institute a Computer Centre, a separate building for Library, a sculpture part, a mega sculptural studio for sculptors and a school for tourists enjoyment are established.



Fig-2: Government College of Architecture and Sculpture, Mamallapuram



Fig-3: Students and faculties are watching the sculpture work in the college

4. Outcome of the Visit

Field Trip provided students with an opportunity to collaborate with teachers and integrate new perspectives with informal environments to enhance learning initiatives. Among the many educational tour benefits, skill development is the most important. Students had the opportunity to apply skills, values and general knowledge in new settings.

Field tour exposed students to different lifestyles, places, people and era. When on educational tour students broaden the understanding of every aspect of the place and its people. Students gained first hand experiences and which will allow teachers to expand the topic which is not possible during the normal class.

II. Art and Sculpture Work as an entrepreneurial Activity: An Industrial Visit to Mahabalipuram (13.03.2019)

1. Preamble

Industrial visit has its own importance in a career of a student who is pursuing a professional degree. It is considered as a part of college curriculum and objectives of industrial visit is to provide students an insight regarding internal working of companies. We know, theoretical knowledge is not enough for making a good professional career. With an aim to go beyond academics, industrial visit provides student a practical perspective on the world of work. Following the same lines students of B.Com General and A &F got an opportunity to visit the art and Sculpture work at Mahabalipuram.

2. List of the Name of Participants

2.1 List of the Name of Students (199 Students)

B.Com. General, 'A' II Semester

S.No.	Name	RRN
1	Aakamksha. S	181291601001
2	Aaliya. A	181291601002
3	Aarthy. S	181291601003
4	Abbas Ali. Y	181291601004
5	Abdul Basith. S	181291601005
6	Abdul Halith. A	181291601006
7	Abdul Hameed. B	181291601007



8	Abdul Rahman Sharafath	181291601008
9	Abul Hasan. A	181291601009
10	Afrin Bargana	181291601010
11	Aishwarya. B	181291601011
12	Ajeesh Ali. N	181291601012
13	Ajith Kumar. S	181291601013
14	Akash. R	181291601014
15	Akbar Ansiya. A	181291601015
16	Alameen. A	181291601016
17	Altrin Jeberson. J	181291601017
18	Anbarasan. K	181291601018
19	Anis Fathima. N	181291601019
20	Anusha. S	181291601020
21	Appas Kasim. K	181291601021
22	Aravindan. K	181291601022
23	Aravindan. R	181291601023
24	Aravindar. N	181291601024
25	Arni Mohammed Saquib Aslam	181291601025
26	Arshad Khan. I	181291601026
27	Arshiya Yasmeen. S.J	181291601027
28	Arulmurugan. B	181291601028
29	Arun Kumar. A	181291601029
30	Arun Kumar. J	181291601030
31	Arun Kumar. S	181291601031
32	Arun Vignesh. M	181291601032
33	Arunachalam. T	181291601033
34	Asma. A	181291601034
35	Ayas Ahamed. S	181291601035
36	Aysha Begum. F	181291601036
37	Balaji. M	181291601037
38	Balamurugan. V	181291601038
39	Balasubramaniyan.M	181291601039
40	Balkis Bee. S	181291601040
41	Barath. D	181291601041
42	Barath. G	181291601042
43	Bhavani. D	181291601043
44	Bhuvanesh. S	181291601044
45	Brindha. K	181291601045
46	Christopher. A	181291601046
47	David Raj. J	181291601047
48	Deepak Kumar. S	181291601048
49	Deepak P	181291601049
50	Deepak. K	181291601050
51	Deepika. C	181291601051
52	Deepika. M	181291601052

53	Deepika. V	181291601053
54	Devadharshini. J	181291601054
55	Dhanalakshmi. P	181291601055
56	Dhanalakshmi. S	181291601056
57	Dharshini. T	181291601057
58	Dhivya Christy. R	181291601058
59	Dillibabu. K	181291601059
60	Dillieeswari. R	181291601060
61	Dinesh Babu. R	181291601061
62	Dinesh Kumar. N	181291601062
63	Dinesh. P	181291601063
64	Elangovan. M	181291601064
65	Faheem Ahmed	181291601065
66	Faizan Basha. M	181291601066

B.Com. General, 'B' II Semester

S.No.	NAME	RRN
1	Farheen Munvarudeen	181291601067
2	Firdous Banu. N. D	181291601068
3	Gajalakshmi. J	181291601069
4	Ganashree. V	181291601070
5	Ganesan	181291601071
6	Ganesh. U	181291601072
7	Gnana Jenin. G	181291601073
8	Gopinath. S	181291601074
9	Govardhan.K	181291601075
10	Gowtham. M	181291601076
11	Hamid Shageel Ibrahim. M	181291601077
12	Hari Prasad. R	181291601078
13	Hariharan. P	181291601079
14	Hariharan. S	181291601080
15	Harine. S	181291601081
16	Hariprasath. S	181291601082
17	Haris Ali. J	181291601083
18	Harish. A	181291601084
19	Harivignesh. R	181291601085
20	Harsha. U	181291601086
21	Hashim Ibrahim. B	181291601087
22	Hassan Abdul Kader. A	181291601088
23	Hema Priya. R	181291601089
24	Hemamalini. M	181291601090
25	Husein Bin Seeni Abdul Rahman	181291601091
26	Imran. S	181291601092
27	Imthiyas Ahamed	181291601093

28	Infant Brittan. A	181291601094
29	Irshad Ahamed. N	181291601095
30	Jabez Sundar Singh. R	181291601096
31	Jacob Daniel. A	181291601097
32	Jaffar. S	181291601098
33	Jagadeesh. A	181291601099
34	Jagadeesh. D	181291601100
35	Jagan. P	181291601101
36	Jamal Mohammed. M	181291601102
37	Janaki. G	181291601103
38	Janani. B	181291601104
39	Janani. R	181291601105
40	Jawahar. R	181291601106
41	Jaya Priya. A	181291601107
42	Jayashree. S	181291601108
43	Jeeva Venkatesh. S	181291601109
44	Jeevananthan. T	181291601110
45	Jeevitha. S	181291601111
46	Jena. J.K	181291601112
47	Kamali. G	181291601113
48	Kanzool. M	181291601114
49	Karthikeyan. E	181291601115
50	Kasthuri. S	181291601116
51	Kaviya. B	181291601117
52	Keerthika. M	181291601118
53	Kiruthika Lakshmi. J	181291601119
54	Kiruthika. M	181291601120
55	Kishore Kumar. S	181291601121
56	Kishore. V	181291601122
57	Krishnakishore. N	181291601123
58	Kumar. P	181291601124
59	Lavanya. G	181291601125
60	Leelavathy	181291601126
61	Logachandar. K	181291601127
62	Logesh. C	181291601128
63	Logeshwaran. M	181291601129
64	Madhavan. G	181291601130
65	Madhesh. M	181291601131
66	Madheshwaran. S	181291601132
67	Madhumitha. M.R	181291601133

B.Com. General, 'D' II Semester

S.No.	NAME	RRN
1	Pavithra. R	181291601197
2	Pawan Kumar. A	181291601198
3	Pooja. P	181291601199
4	Prabhakar. G	181291601200
5	Prasanna Venkatesh. K	181291601201
6	Prasanna. M	181291601202
7	Prasath. M	181291601203
8	Praveen Kumar. S	181291601204
9	Praveena Mary	181291601205
10	Praveena. M	181291601206
11	Preethi. M	181291601207
12	Prisilla Mercy. P	181291601208
13	Priya. S	181291601209
14	Purvaja.G	181291601210
15	Raghuraman. M	181291601211
16	Rahamathullah. K	181291601212
17	Raja Subramanian. R.G	181291601213
18	Rajesh Kumar. P.S	181291601214
19	Rakesh. G	181291601215
20	Ramyasree. D.G	181291601216
21	Ranjith. B	181291601217
22	Rekha. H	181291601218
23	Riyas Ahamed. H	181291601219
24	Rizwana. J	181291601220
25	Roshini. S	181291601221
26	Sai Venkatraman. R.N	181291601222
27	Saifullah. S	181291601223
28	Sajid. H	181291601224
29	Sajiya Banu. S	181291601225
30	Salini. K	181291601226
31	Sameer Ahamed. J	181291601227
32	Sameera Fathima. I	181291601228
33	Samreen Hina Fathima. M.S.	181291601229
34	Samsudeen. J	181291601230
35	Samsudeen. M	181291601231
36	Sandhiya. K	181291601232
37	Sangeetha. S O	181291601233
38	Santhiya . E.A	181291601234
39	Santhiya. L	181291601235
40	Santhosh. M	181291601236
41	Santhosh. U	181291601237
42	Saranya. P	181291601238

43	Saranya. S	181291601239
44	Sarath Kumar. K	181291601240
45	Sasikala. R	181291601241
46	Sethupathi M	181291601242
47	Shaanjai. D	181291601243
48	Shaik Alif Basha. S	181291601244
49	Shaik Rasheeth. M	181291601245
50	Shaistha Farheen. F	181291601246
51	Shalini. D	181291601247
52	Sharan Raj. S	181291601248
53	Sharan. G	181291601249
54	Sharanya. U	181291601250
55	Sharif. K	181291601251
56	Shariqa Tabassum. Z	181291601252
57	Sharmi. C	181291601253
58	Sharmila. R	181291601254
59	Shibana. A	181291601255
60	Shivi Krishnan. K	181291601256
61	Shofiya. D	181291601257
62	Shreekanth. R	181291601258
63	Shri Ramana Rishi. R	181291601259
64	Shridhar. H	181291601260
65	Siddique. P.K.	181291601261
66	Siva Kumar. V	181291601262

S.No.	Name of the faculty Members	Designation
1	Dr. Nirmala S	Assistant Professor
2	Dr. Sibghatullah Nasir	Assistant Professor
3	Dr. Murali	Assistant Professor
4	Dr. Rathika Meghanathan	Assistant Professor
5	Dr. Kogila N	Assistant Professor

3. Salient Features of the Industrial Visit

3.1 Mahabalipuram: A Place of Rock and Stone Sculpture

Mahabalipuram or Mamallapuram is an ancient port city in the Kancheepuram district of Tamil Nadu. Once a bustling seaport and a busy trading centre, the place is now one of the major tourist attractions near Chennai. Mahabalipuram has a rich history and heritage that is well-preserved to date and speaks volumes of its glory. Mahabalipuram is one of the oldest cities in India. Present day, it is known for its great monuments, cave sanctuaries and sculptures. A monument complex at Mahabalipuram, known as the Group of Monuments, with all its rock art and relief sculptures, is a UNESCO world site.

The famous Pancha Rathas (also known as Pandava Rathas) (late 7th century) is an example of monolithic Indian rock-cut architecture. Each of the five monuments in the Pancha Rathas complex resembles a chariot (ratha), and each is carved over a single, long stone or monolith, of granite which slopes in north-south direction with a slight incline

It is a sculpture town, and on either side of the roads one would find display of sculptures and paintings. The numerous temples and rock carvings are classic examples of South Indian temple art and its evolution during the reign of the Pallava kings. The town not only has a beautiful beach, a British era Light-house, but numerous interesting rock formations as well. The place is still the centre of stone carving.

3.2 Government College of Architecture and Sculpture, Mamallapuram

The Government College of Architecture and Sculpture was established in Mamallapuram in 1957. Four-Year Degree Courses are offered in this College from 2000-2001. B.Tech in Traditional Architecture, B.F.A in Traditional Sculpture and B.F.A in Traditional Drawing and Painting are offered. Considering the Development of this Institute a Computer Centre, a separate building for Library, a sculpture part, a mega sculptural studio for sculptors and a school for tourists enjoyment are established.



Fig-1: Government College of Architecture and Sculpture, Mamallapuram



Fig-1: Students are ready to start the industrial visit project



Fig-2: Students are watching the sculpture in the museum

4. Outcome of the Visit

Field Trip provided students with an opportunity to collaborate with teachers and integrate new perspectives with informal environments to enhance learning initiatives. Among the many educational tour benefits, skill development is the most important. Students had the opportunity to apply skills, values and general knowledge in new settings.

Field tour exposed students to different lifestyles, places, people and era. When on educational tour students broaden the understanding of every aspect of the place and its people. Students gained first hand experiences and which will allow teachers to expand the topic which is not possible during the normal class.

III. Art and Sculpture Work in the eyes of Commerce students: An Industrial Visit to Mahabalipuram (14.03.2019)

1. Preamble

Industrial visit has its own importance in a career of a student who is pursuing a professional degree. It is considered as a part of college curriculum and objectives of industrial visit is to provide students an insight regarding internal working of companies. We know, theoretical knowledge is not enough for making a good professional career. With an aim to go beyond academics, industrial visit provides student a practical perspective on the world of work. Following the same lines students of B.Com General and A &F got an opportunity to visit the art and Sculpture work at Mahabalipuram.

2. List of the Name of Participants

2.1 List of the Name of Students (252 Students)

B.Com. General, 'C' II Semester

S.No.	NAME	RRN
1	Magesh. N	181291601134
2	Mahalakshmi. N.J	181291601135
3	Mahalakshmi. R	181291601136
4	Maideen Beevi	181291601137
5	Mani. D	181291601138
6	Manikandan. M	181291601139
7	Manikandan. P	181291601140
8	Manoj Kumar. K	181291601141
9	Maria Fastina. M	181291601142
10	Megalavathi. R	181291601143
11	Mohamed Akaz. M	181291601144
12	Mohamed Arif Hussain. H	181291601145
13	Mohamed Basith. J	181291601146
14	Mohamed Esaah	181291601147

15	Mohamed Fahan. T	181291601148
16	Mohamed Fahath. Z	181291601149
17	Mohamed Faij Ali. S	181291601150
18	Mohamed Ibrahim. S	181291601151
19	Mohamed Irban. S	181291601152
20	Mohamed Jaasir. T.H.	181291601153
21	Mohamed Mahadhir. V.N	181291601154
22	Mohamed Misfer	181291601155
23	Mohamed Mubin. M	181291601156
24	Mohamed Mujahith Ali. J	181291601157
25	Mohamed Naufal. N	181291601158
26	Mohamed Pathuloon Faizal .M	181291601159
27	Mohamed Rasmi. R	181291601160
28	Mohamed Sahil	181291601161
29	Mohamed Salman. J	181291601162
30	Mohamed Sameer. M	181291601163
31	Mohamed Shifa. M	181291601164
32	Mohamed Suhail Ali	181291601165
33	Mohamed Wasim. N	181291601166
34	Mohamed Yoonus	181291601167
35	Mohamed Zuhail. M	181291601168
36	Mohammed Ashik. A	181291601169
37	Mohammed Ibahith. N	181291601170
38	Mohammed Mufaris	181291601171
39	Mohammed Nazeer. M	181291601172
40	Mohammed Rafi. M	181291601173
41	Mohammed Razik. H	181291601174
42	Mohammed Rhiswan. M	181291601175
43	Mohammed Riyaz. R	181291601176
44	Mohammed Salmon. N	181291601177
45	Mohammed Samsul Ajees	181291601178
46	Mohammed Siddiq. S	181291601179
47	Mohammed Sulaiman. A.W	181291601180
48	Mohammed Thoufeeq	181291601181
49	Mohana Priya. S	181291601182
50	Monesh. M	181291601183
51	Mugundha Priya. N	181291601184
52	Murali. R	181291601185
53	Nadar Jayalakshmi Arulraj	181291601186
54	Najmudeen. A	181291601187
55	Nandhini. D	181291601188
56	Nandhini. L	181291601189
57	Nanthakumar. S	181291601190
58	Naresh Kumar C	181291601191
59	Nasrin Kamroon. A	181291601192

60	Nishitha. N	181291601193
61	Nivetha. P	181291601194
62	Niyaz Khaan. M	181291601195
63	Parthiban. G	181291601196

B.Com. General, 'E' II Semester

S.No.	NAME	RRN
1	Ahmed. U.K	181291601263
2	Ashraf Khan. A	181291601264
3	Ashraff Ali Khan. A	181291601265
4	Ayesha Mariam	181291601266
5	Bhuvan Roshani	181291601267
6	Chandrakanthan. L	181291601268
7	Dinesh Kumar. C	181291601269
8	Farhan Hussain. A	181291601270
9	Inbarasu. R	181291601271
10	Iram Nadeem	181291601272
11	Kaviya. P	181291601273
12	Keerthana	181291601274
13	Kumaran. M	181291601275
14	Lakshmi. E	181291601276
15	Mohamed Fazil. N	181291601277
16	Mohamed Ubaidulla Khan	181291601278
17	Mohideen Kasali	181291601279
18	Mubashira Dawood Batcha	181291601280
19	Razeen Mohideen. A	181291601281
20	Renuka. K	181291601282
21	Rokesh. G	181291601283
22	Sanjai. S	181291601284
23	Shyamala. T	181291601285
24	Sifnas Begam. T	181291601286
25	Solairaj	181291601287
26	Soma Sekara Sharma	181291601288
27	Soorya Prakash. G	181291601289
28	Soundharya. V	181291601290
29	Sowmiya. S	181291601291
30	Sruthi. R	181291601292
31	Sruthi. Y	181291601293
32	Sunitha. B	181291601294
33	Suresh. D	181291601295
34	Surya Kumar. P	181291601296
35	Surya. L	181291601297
36	Swetha. R	181291601298
37	Syed Naser Hussain. M	181291601299

38	Tamilselvan. D	181291601300
39	Tamiz Selvan. T	181291601301
40	Tanveer Unissa. R	181291601302
41	Thameem Ansari	181291601303
42	Thameem Ansari. M	181291601304
43	Thirulogachandar. V	181291601305
44	Ukkash Ali. S	181291601306
45	Vaishali. S	181291601307
46	Varsha. R	181291601308
47	Varun Kumar. L	181291601309
48	Vasanth. B	181291601310
49	Vasuki. M	181291601311
50	Veerajothi. U	181291601312
51	Vengadeshwaran. K	181291601313
52	Venkat Karthick, M	181291601314
53	Vignesh. K	181291601315
54	Vignesh. S	181291601316
55	Vigneshwaran. B	181291601317
56	Vigneshwaran. R	181291601318
57	Vigneshwaran. S	181291601319
58	Vigneshwari. S	181291601320
59	Vijay. P	181291601321
60	Vijay. S	181291601322
61	Vinitha Sri. J	181291601323
62	Vishnu Priya. R	181291601324
63	Yamuna Sree. G	181291601325
64	Yashwanth. V	181291601326
65	Yogesh. K	181291601327
66	Yugendar. J	181291601328
67	Yukenthran. P	181291601329
68	Yuvaraj. G	181291601330
69	Yuvaraj. S	181291601331

B.Com. A&F, 'A' II Semester

S.No.	NAME	RRN
1	Abdul Gafoor. A	181411601001
2	Abdul Hameed. M	181411601002
3	Abdul Rahman. M	181411601003
4	Abinaya. N	181411601004
5	Adhil Mohamed. M	181411601005
6	Ahamed Noufal. P.M	181411601006

7	Aishwarya. S	181411601007
8	Amreen. A	181411601008
9	Anbumani. K	181411601009
10	Arun Kumar. D	181411601010
11	Bharath. K	181411601011
12	Bharathi Michala Babu	181411601012
13	Bhavan Kaviyarashan	181411601013
14	Bhuvaneshwari. K	181411601014
15	Dhana Lakshmi. G	181411601015
16	Divya. V	181411601016
17	Epsiba. B	181411601017
18	Faizal. A	181411601018
19	Fayaz Rahman. H	181411601019
20	Fortune. J	181411601020
21	Gokul Vishnu. E	181411601021
22	Gunasundari. M	181411601022
23	Harish. R	181411601023
24	Jaikrishna. R	181411601024
25	Jainul Mukthaar. R.A	181411601025
26	Jayalalitha. S.A	181411601026
27	Jothieshwari. K	181411601027
28	Kalaisen. S	181411601028
29	Kameshwar. P.M	181411601029
30	Karthik. K	181411601030
31	Keerthana. S	181411601031
32	Keerthi Vasan. K	181411601032
33	Khader Meeran. K.M	181411601033
34	Kirupakaran. M	181411601034
35	Kishore. S	181411601035
36	Kruthika. D	181411601036
37	Logesh. C	181411601037
38	Manjula. V	181411601038
39	Martina Vency. V	181411601039
40	Meenatchi	181411601040
41	Michel Raxon Bush. J	181411601041
42	Mohamad Sheik Shamrul. K	181411601042
43	Mohamed Fareez. Y	181411601043
44	Mohamed Ibrahim.J	181411601044
45	Mohamed Ibrahim. S	181411601045
46	Mohamed Imran. Y	181411601046
47	Mohamed Rahid. H	181411601047
48	Mohamed Safwan. S	181411601048
49	Monika. S	181411601049
50	Nandagopala	181411601050
51	Narmatha. U	181411601051

52	Neshik Ganth. S	181411601052
53	Nisha. P	181411601053
54	Kashav Bhatra	181411601119

B.Com. A&F, 'B' II Semester

S.No.	NAME	RRN
1	Anish. C	181411601054
2	Dhuwahar. E	181411601055
3	Diana Elizebeth. R.D	181411601056
4	Hafis Muhammed. V	181411601057
5	Mohamad Zakaria	181411601058
6	Mohamed Asif H	181411601059
7	Mohamed Ibrahim Sadiq	181411601060
8	Mohammad Shaffan	181411601061
9	Mohammed Aashik. N	181411601062
10	Mohammed Imran. S	181411601063
11	Mohammed Reyas. M	181411601064
12	Muhammad Imran. M	181411601065
13	Palavesakaran. K	181411601066
14	Pavithra. B	181411601067
15	Prasanth. R	181411601068
16	Rafeena Raja. R	181411601069
17	Ragul Krishnan. M	181411601070
18	Rahul. R	181411601071
19	Rajan. J.S	181411601072
20	Rajesh. P	181411601073
21	Rajesh. S.L	181411601074
22	Ramya. R	181411601075
23	Reena Razeetha. P	181411601076
24	Revathi. R.A	181411601077
25	Roshan Jacob. J	181411601078
26	Rudhramoorthy. R	181411601079
27	Ruthick Adithya. S	181411601080
28	Saiprasath. S	181411601081
29	Sakthi Anbazhagan. S	181411601082
30	Sakthi Sri. K	181411601083
31	Sankar Narayanan. K	181411601084
32	Sathishkumar. N	181411601085
33	Shabana. A	181411601086
34	Shafeeq Kurikkal	181411601087
35	Sneha V Patel	181411601088
36	Sreenesh S Pai	181411601089
37	Sri Ramanan. A.M	181411601090
38	Srivatsan. K	181411601091

39	Sruthi. I	181411601092
40	Sruthi.I	181411601093
41	Stephen. C	181411601094
42	Subhiksha. R	181411601095
43	Sunil. S	181411601096
44	Surekha. S	181411601097
45	Suruthi. R	181411601098
46	Swathi Manoj	181411601099
47	Swetha. S	181411601100
48	Syed Imran. S	181411601101
49	Tharini. V	181411601102
50	Thawfick Sulthan. M	181411601103
51	Thomas. K	181411601104
52	Umaar Mohamed .M.S	181411601105
53	Vasanthakumar. P	181411601106
54	Vignesh. K.L	181411601107
55	Vijay Kumar. S	181411601108
56	Vishnu Prasath. V	181411601109
57	Wasim Akram	181411601110
58	Yeshwanthi. T	181411601111
59	Yogesh. K	181411601112
60	Mohamed Iqbal Bin Mohamed	181411601113
61	Sri Lakshmi. B.V	181411601114
62	Mohamed Wazir. M	181411601115
63	Mohamed Ishak	181411601116
64	Muhamed Sanah	181411601117
65	Niphin. K.R	181411601118
66	Mohideen Mubarak. V.M.H	181411601120

2.2 List of the names of Faculty members

S.No.	Name of the faculty Members	Designation
1	Dr. Nirmala S	Assistant Professor
2	Dr. Sibghatullah Nasir	Assistant Professor
3	Dr. Murali	Assistant Professor
4	Dr. Rathika Meghanathan	Assistant Professor
5	Dr. Ziavuddin	Assistant Professor

3. Salient Features of the Industrial Visit

3.1 Mahabalipuram: A Place of Rock and Stone Sculpture

Mahabalipuram or Mamallapuram is an ancient port city in the Kancheepuram district of Tamil Nadu. Once a bustling seaport and a busy trading centre, the place is now one of the major tourist attractions near Chennai. Mahabalipuram has a rich history and

heritage that is well-preserved to date and speaks volumes of its glory. Mahabalipuram is one of the oldest cities in India. Present day, it is known for its great monuments, cave sanctuaries and sculptures. A monument complex at Mahabalipuram, known as the Group of Monuments, with all its rock art and relief sculptures, is a UNESCO world site.

The famous Pancha Rathas (also known as Pandava Rathas) (late 7th century) is an example of monolithic Indian rock-cut architecture. Each of the five monuments in the Pancha Rathas complex resembles a chariot (ratha), and each is carved over a single, long stone or monolith, of granite which slopes in north-south direction with a slight incline

It is a sculpture town, and on either side of the roads one would find display of sculptures and paintings. The numerous temples and rock carvings are classic examples of South Indian temple art and its evolution during the reign of the Pallava kings. The town not only has a beautiful beach, a British era Light-house, but numerous interesting rock formations as well. The place is still the centre of stone carving

3.2 Government College of Architecture and Sculpture, Mamallapuram

The Government College of Architecture and Sculpture was established in Mamallapuram in 1957. Four-Year Degree Courses are offered in this College from 2000-2001. B.Tech in Traditional Architecture, B.F.A in Traditional Sculpture and B.F.A in Traditional Drawing and Painting are offered. Considering the Development of this Institute a Computer Centre, a separate building for Library, a sculpture part, a mega sculptural studio for sculptors and a school for tourists enjoyment are established.



Fig-1: Government College of Architecture and Sculpture, Mamallapuram



Fig-2: Students are in museum to understand the ancient Indian tradition



Fig-3: Taking rest during the industrial visit.

4. Outcome of the Visit

Field Trip provided students with an opportunity to collaborate with teachers and integrate new perspectives with informal environments to enhance learning initiatives. Among the many educational tour benefits, skill development is the most important. Students had the opportunity to apply skills, values and general knowledge in new settings.

Field tour exposed students to different lifestyles, places, people and era. When on educational tour students broaden the understanding of every aspect of the place and its people. Students gained first hand experiences and which will allow teachers to expand the topic which is not possible during the normal class.

IV. Art and Sculpture Work as an Entrepreneurial Activity: An Industrial Visit to Mahabalipuram (11.04.2019)

1. Preamble

Industrial visit has its own importance in a career of a student who is pursuing a professional degree. It is considered as a part of college curriculum and objectives of industrial visit is to provide students an insight regarding internal working of companies. We know, theoretical knowledge is not enough for making a good professional career. With an aim to go beyond academics, industrial visit provides student a practical perspective on the world of work. Following the same lines students of B.Com General and A & F and BBA (Financial Services) got an opportunity to visit the art and Sculpture work at Mahabalipuram.

2. List of the Name of Participants

2.1 List of the Name of Students (293 students)

B. Com. General 'B' IV Semester

S.No.	NAME	RRN
1	Harini R	171291601054
2	Hari Prasad A	171291601055
3	Harish S	171291601056
4	Hemeshwar V	171291601057
5	Karishma Sultana S	171291601058
6	Maisun Nisha Mohamed Mubees	171291601059
7	Rihan Nathik S	171291601060
8	Shabana Fathima A R	171291601061
9	Shamira A	171291601062
10	Steeve Jabez S	171291601063
11	Zohara Fathima G	171291601064
12	Aseem Abdullah M	171291601065
13	Irshath Hassan A J	171291601066
14	Jagadeesh Prasath M	171291601067



15	Jagadeeshwaran K	171291601068
16	Janaki S	171291601069
17	Jaya V	171291601070
18	Jeganthan B	171291601071
19	Kamalesh H	171291601072
20	Kausalya K S	171291601073
21	Kavitha V	171291601074
22	Kavivarshini K	171291601075
23	Kaviya P	171291601076
24	Kishore V	171291601077
25	Kumaran S	171291601078
26	Labha Vardhana V	171291601079
27	Lakshmi Narasimalu M	171291601080
28	Leena Banu B	171291601081
29	Lokesh Babu T	171291601082
30	Lokesh Kumar S	171291601083
31	Magesh Kumar T	171291601084
32	Manuvel S	171291601085
33	Marvin Mildon J	171291601086
34	Marzook Ahmed M M	171291601087
35	Melvin Prakash R	171291601088
36	Mohamed Abbas J	171291601089
37	Mohamed Akeel M A	171291601090
38	Mohamed Akram Sha N	171291601091
39	Mohamed Anas S	171291601092
40	Mohamed Asimudeen E	171291601093
41	Mohamed Azleem Gani B	171291601094
42	Mohamed Fazil M	171291601095
43	Mohamed Hafeez M	171291601096
44	Mohamed Laeeq M	171291601097
45	Mohamed Mujammil J	171291601098
46	Mohamed Riswan K S	171291601099
47	Mohamed Sabith M S	171291601100
48	Mohamed Sameerkhan K	171291601101
49	Mohamed Sulaiman B	171291601102
50	Mohamed Thofik M I	171291601103
51	Mohamed Uwaise A	171291601104
52	Mohamed Umar K	171291601106
53	Mohammed Anees S	171291601107

B. Com. General 'C' IV Semester

S.No.	NAME	RRN
-------	------	-----

1	Mohammed Ibrahim.I.S	171291601108
2	Mohammed Rashik. T	171291601109
3	Mohammed Refaideen. H	171291601110
4	Mohana Priya. R	171291601111
5	Mohideen Badurunnisa Fazana. V.A	171291601112
6	Moyisun. M	171291601113
7	Mugesh Kanna. S	171291601114
8	Muhammad Azmath Althaf. A	171291601115
9	Murugan. T	171291601116
10	Nandhini. N	171291601117
11	Nandhini. P	171291601118
12	Nasreen. S	171291601119
13	Naveen. R	171291601120
14	Niranjan. M	171291601121
15	Nithya Sri. G	171291601122
16	Nivetha. B	171291601123
17	Noorul Ameen. H.R	171291601124
18	Parthiban. R	171291601125
19	Pavithra. J	171291601126
20	Prabhakaran. S	171291601127
21	Sanjana. L	171291601128
22	Yasir Ali. S.A	171291601129
23	Deepasrika. S	171291601130
24	Pavithra. M	171291601131
25	Pavithra. R	171291601132
26	Pon Subhasri Lakshmi. N	171291601133
27	Poongaothai. E	171291601134
28	Pradeep Kumar. V	171291601135
29	Prasanth. T	171291601136
30	Preethi. P	171291601137
31	Priyadharshini. P	171291601138
32	Praveen Kumar. L	171291601139
33	Radha Bai. D	171291601140
34	Rajesh. H	171291601141
35	Rakesh. K.P	171291601142
36	Rakesh. M	171291601143
37	Ramya. B.R	171291601144
38	Ramyaa. D	171291601145
39	Ranjith. L	171291601146
40	Rathina Balaa. R	171291601147
41	Raviraja. N	171291601148
42	Riaz Ahmed. S	171291601149
43	Rubesh. T	171291601150

44	Ruckmani. D	171291601151
45	Sabari. K	171291601152
46	Sairam. P	171291601153
47	Saithoon Rahmath. I	171291601154
48	Sajid Ahamed	171291601155
49	Salamath Nisha. A	171291601156
50	Salman Baris. S	171291601157
51	Sameera Parveen. A	171291601158
52	Sanjana. B	171291601159
53	Santhosh kumar. V	171291601160

B. Com. General 'D' IV Semester

S.No.	NAME	RRN
1	Santhosh Kumar. M	171291601161
2	Santhoshini. S	171291601162
3	Santhya. A.K	171291601163
4	Sarath. E.B	171291601164
5	Sathish. B	171291601165
6	Sathish kumar. D	171291601166
7	Sathishkumar. S	171291601167
8	Sathyanarayanan. B	171291601168
9	Sedhu Madhavan. C	171291601169
10	Seethalakshmi. G	171291601170
11	Shafeeq Ahmed. A	171291601171
12	Shahidha Fathima. A	171291601172
13	Shaik Jameer. J	171291601173
14	Shalini. S	171291601174
15	Sharan. C.S	171291601175
16	Sharan. R	171291601176
17	Sivaranjani. M	171291601177
18	Sivasankar. S	171291601178
19	Sneha. M	171291601179
20	Soundarya. A	171291601180
21	Srihari Bala. S	171291601181
22	Subalekha. M	171291601182
23	Subash Chandran. N	171291601183
24	Subha. K	171291601185
25	Sudhakar. P	171291601186
26	Surekha. R	171291601187
27	Suresh. K	171291601188
28	Vaitheeswaran. A	171291601189
29	Vignesh. S	171291601190

30	Vimal Kumar. B	171291601191
31	Yuvan Shankar. B	171291601192
32	Dheekshath. S	171291601193
33	Fahil Fazeen	171291601194
34	Humayun Samathani. V.M.S.A	171291601196
35	Mohammed Nihad. M	171291601197
36	Sahul Hameed. S	171291601198
37	Shajitha. M	171291601199
38	Syed Arif Ali. G	171291601201
39	Syed Mohammed Afridee	171291601202
40	Syed Nadeem. F	171291601203
41	Syed Sathak Shahul Hameed. M.N	171291601204
42	Tamilselvan. K	171291601205
43	Thamimunansari. M	171291601206
44	Thenmozhi. I	171291601207
45	Vibisha. R	171291601208
46	Vidhya. M	171291601209
47	Vignesh. P	171291601210
48	Vignesh. K	171291601211
49	Wasim Ahamed. B	171291601212
50	Yashmeen. Y	171291601213
51	Yuvashree. K	171291601214
52	Yuvashree. R	171291601215
53	Vishal Aadhithya. P	171291601216

BBA (Financial Services) II Semester

S.No.	NAME	RRN
1	Abd Manaf .M	181491601001
2	Abdul Rahman.S	181491601002
3	Abik shemil K.S	181491601003
4	Akash R.S	181491601004
5	Akashwaran M.U	181491601005
6	Aliya rizwan	181491601006
7	Amuthini .v	181491601007
8	Ashik Ahmed. M	181491601008
9	Balaji.D	181491601009
10	Devadharshini .R	181491601010
11	Divya .A	181491601011
12	Fahima ishrath jamila	181491601012
13	Harish.M	181491601013
14	Irfan ummer	181491601014
15	Jahaber fazil.H	181491601015
16	Jai rakshith	181491601016



17	Jannathul firdouse .A	181491601017
18	Jawahar A.P	181491601018
19	Jeevitha .Y	181491601019
20	Karunya T.	181491601021
21	Madesh.H	181491601022
22	Madhan raj. S	181491601023
23	Madhana gopal.R	181491601024
24	Manisha reddy .S	181491601025
25	Maria ruban	181491601026
26	Mohamed basha.J	181491601027
27	Mohamed hamdhan	181491601028
28	Mohamed jackaria.M	181491601029
29	Mohammed jaseem.A	181491601030
30	Mohammed mahadhir.M	181491601031
31	Mohamed musharaf	181491601032
32	Mohamed noorul ameen.K	181491601033
33	Mohamed othman Mubeen.M	181491601034
34	Mohamed sahiyudheen.R	181491601035
35	Mohamed. A	181491601037
36	Mohamed asraf.J	181491601039
37	Mohamed abid.A	181491601040
38	Mohamed jabin gafoor.M	181491601042
39	Mohan avinash raj.R.E	181491601043
40	Monisha .N	181491601044
41	Muhammad Shaheem	181491601045
42	Munawar mohammed kavungal	181491601046
43	Mushraf. D	181491601047
44	Musthaq ahmed	181491601048
45	Muthuvel.S	181491601049
46	Muzammil dheensha.A	181491601050
47	Nauman.I	181491601051
48	Niraimathi	181491601052
49	Nivedha.U	181491601053
50	Onkar Nath Rai	181491601054
51	Prakadeesh yuvaraj.P	181491601055
52	Prathana.B	181491601056
53	Rajapandi.P	181491601058
54	Rayees abdulla kavungal	181491601059
55	Roitul hussain.A	181491601061
56	Navin.S	181491601062
57	Salman faris	181491601063
58	Saundaya .R	181491601065
59	Shawn hebreaq H.S	181491601067
60	Subitcha kaliya perumal	181491601068
61	Suresh Kumar.S	181491601069
62	Surya .R	181491601070
63	Syed fizal.M	181491601071
64	Venati sathvika	181491601072
65	Vignesh.I	181491601073

66	Elakiya.N	181491601074
----	-----------	--------------

2.2 List of the Names of Faculty Members

S.No.	Name of the faculty Members	Designation
1	Dr. Abuzar Nomani	Assistant Professor
2	Dr. Sibghatullah Nasir	Assistant Professor
3	Ms. S. Farzana	Assistant Professor
4	Dr. Rathika Meghanathan	Assistant Professor
5	Ms. Saba Khan(Escort)	Research Scholar

3. Salient Features of the Industrial Visit

3.1 Mahabalipuram: A Place of Rock and Stone Sculpture

Mahabalipuram or Mamallapuram is an ancient port city in the Kancheepuram district of Tamil Nadu. Once a bustling seaport and a busy trading centre, the place is now one of the major tourist attractions near Chennai. Mahabalipuram has a rich history and heritage that is well-preserved to date and speaks volumes of its glory. Mahabalipuram is one of the oldest cities in India. Present day, it is known for its great monuments, cave sanctuaries and sculptures. A monument complex at Mahabalipuram, known as the Group of Monuments, with all its rock art and relief sculptures, is a UNESCO world site.

The famous Pancha Rathas (also known as Pandava Rathas) (late 7th century) is an example of monolithic Indian rock-cut architecture. Each of the five monuments in the Pancha Rathas complex resembles a chariot (ratha), and each is carved over a single, long stone or monolith, of granite which slopes in north-south direction with a slight incline

It is a sculpture town, and on either side of the roads one would find display of sculptures and paintings. The numerous temples and rock carvings are classic examples of South Indian temple art and its evolution during the reign of the Pallava kings. The town not only has a beautiful beach, a British era Light-house, but numerous interesting rock formations as well. The place is still the centre of stone carving

3.2 Government College of Architecture and Sculpture, Mamallapuram

The Government College of Architecture and Sculpture was established in Mamallapuram in 1957. Four-Year Degree Courses are offered in this College from

2000-2001. B.Tech in Traditional Architecture, B.F.A in Traditional Sculpture and B.F.A in Traditional Drawing and Painting are offered. Considering the Development of this Institute a Computer Centre, a separate building for Library, a sculpture part, a mega sculptural studio for sculptors and a school for tourists enjoyment are established.



Fig-1: Government College of Architecture and Sculpture, Mamallapuram

Students visited Art and Sculpture College for understand the old and traditional art and sculpture of clay, cement and metal like copper and brass. They made understand how to manufacture these articles of traditional art. They knew the difference between modern arcitecture and traditional arcitecture. The techers of this college coopereted very much like their own student and tell them about the opportunities and challenges of this art.



Fig-2: Students in bus while going for Industrial visit

4. Outcome of the Visit

Field Trip provided students with an opportunity to collaborate with teachers and integrate new perspectives with informal environments to enhance learning initiatives. Among the

many educational tour benefits, skill development is the most important. Students had the opportunity to apply skills, values and general knowledge in new settings.

Field tour exposed students to different lifestyles, places, people and era. When on educational tour students broaden the understanding of every aspect of the place and its people. Students gained first hand experiences and which will allow teachers to expand the topic which is not possible during the normal class

Field Visit Co-ordinators

1. Dr. Rathika Meganathan
2. Dr. Nirmala SS
3. Dr. Kogila N
4. Mr. Murli M
5. Dr. Sibghatullah Nasir



2/11/19
PROFESSOR & HEAD
Department of Commerce
B.S. Abdur Rahman
Crescent
Institute of Science & Technology
Vandalur, Chennai-600 048
HOD Commerce

Report of Industrial Visit

Session 2019-19

**B. Com. General, B. Com. (A&F) and BBA (Financial Services)
II Year and III Year**

Dates of the Visits

14-17 Oct, 2019	:	B.Com. General, III Year B.Com. A&F, III Year
17-18 Oct, 2019	:	B.Com. General, II Year, Section B.Com A&F, II Year
21-22 Oct 2019	:	BBA Financial Services II Year

**Department of Commerce
B. S. Abdurrahman Crescent Institute of Science & Technology
Chennai - 600048**

Industrial Visit Report

I. Commerce Students at God's Own Country: An Industrial Visit (14-17 Oct. 2019)

1. Preamble

Industrial visit is a part of professional courses, during which students visit companies and get insight of on the internal working environment of the company. Industry visits sensitize students to the practical challenges that organizations face in the business world. Industrial visits also give greater clarity about various management concepts for students as they can practically see how these concepts are put into action. Visits to manufacturing firms are useful for students. To understand the nuances and realities of the shop floor, this in itself is a rare exposure. By visiting the shop floor they get to understand the risky conditions in which workers work, the people management challenges involved in managing workers apart from getting hands-on technical knowledge.

Tea or Chai is the most widely drunk beverage in the whole world. The tea plant, *Camellia Sansis*, is a cultivated variety of a tree that has its origins in an area between India and China. There are three main varieties of the tea plant China, Assam, and Cambodia and a number of hybrids between the varieties. The China variety grows as high as nine feet (2.75 metres). It is a hardy plant able to withstand cold winters and has an economic life of at least 100 years.



Fig. 1 Tea manufacturing in Munnar, Karala

The Assam variety, a singlestem tree ranging from 20 to 60 feet (6 to 18 metres) in height. Regular pruning keeps its height to a more manageable 4 to 5 feet tall. It has an economic life of 40 years with regular pruning and plucking. When grown at an altitude near that of Darjeeling (Assam) or Munnar (Kerala), it produces tea with fascinating flavours , sought after around the globe. The Cambodia variety, a singlestem tree growing to about 16 feet (five metres) in height, is not cultivated but has been naturally crossed with other varieties.

2 List of the Names of Participants

2.1 List of the Names of Faculty Members

S.No	Staff Name	Designation
1	Mr. Chandra Shekhar. S	Assistant Professor
3	Dr. Syed Mohsin	Assistant Professor
4	Dr. Mary Angelin	Assistant Professor
5	Ms. Zeenat Fatima	Assistant Professor
6	Mr. Khurram Khowaja	Assistant Professor
7	Ms. Farzana S	Assistant Professor
8	Ms. Ifra Fathima I.	Assistant Professor
9	Mr.Rajendra Prasad C.N.	Assistant Professor (Full time VF)

9	Saba Khan (Escort)	Research Scholar
---	--------------------	------------------

2.2 List of the names of students for Kerala visit

S.No.	Name of the Student	RRN
1	Abdul Jabbar A	171291601002
2	Abdul Jasim . M	171291601003
3	Abdul Kalam Azad.J	171291601004
4	Abdul Rahman.J	171291601005
5	Abdul salik	171291601006
6	ABDUL WAHITH A	171291601007
7	ABINAYA V	171291601008
8	Abinaya. TS	171291601009
9	Ahamed Arish S	171291601012
10	Ajay kumar	171291601014
11	Ajith Kumar K	171291601015
12	Akash s	171291601016
13	Akram.T	171291601018
14	Anish Ahamed	171291601019
15	Anushya.A	171291601020
16	Ashwini.G	171291601021
17	Aswin.D	171291601022
18	Bharath B	171291601026
19	Bharathi. P	171291601028
20	Bhuvana k	171291601029
21	Buganesh S	171291601030
22	Christena T	171291601032
23	Collins Deva Prasad G	171291601033
24	Deepak R	171291601034
25	Deepak raj D	171291601035
26	Deva rajan	171291601037
27	Dhinesh S	171291601038
28	DINESH KUMAR R N	171291601039
29	Divya.v	171291601041
30	Elangovan G	171291601042
31	Gomathi M	171291601049
32	Hameed abdul rahman	171291601051
33	Harini.K	171291601053
34	HARINI R	171291601054
35	Hari prasad	171291601055
36	Harish	171291601056
37	Hemeshwar v	171291601057
38	Karishma sultana S	171291601058
39	Maisun Nisha	171291601059



40	RIHAN NATHIK	171291601060
41	Shabana fathima AR	171291601061
42	Shamira.a	171291601062
43	steeve jabez .s	171291601063
44	Zohara Fathima. G	171291601064
45	IRSHATH HASSAN	171291601066
46	Jagadeeshwaran K	171291601068
47	Janaki s	171291601069
48	Jaya V	171291601070
49	Jeganthan	171291601071
50	Kausalya.k.s	171291601073
51	Kavivarshini k	171291601075
52	Kumaran. S	171291601078
53	Labha vardhana V	171291601079
54	Lakshmi Narasimalu M	171291601080
55	Lokesh Kumar S	171291601083
56	Marzook Ahmed. M. M.	171291601087
57	Mohamed abbas. J	171291601089
58	Mohamed Akeel	171291601090
59	Mohamed akramsha	171291601091
60	Mohamed asimudeen	171291601093
61	Mohamed Fazil.m	171291601095
62	MOHAMMED MUJAMMIL	171291601098
63	Mohamed riswan k s	171291601099
64	MOHAMMED SABITH	171291601100
65	MOHAMMED SULAIMAN	171291601102
66	Mohamed Thofik	171291601103
67	MOHAMMED UWAISE	171291601104
68	Mohammad Umar K	171291601106
69	Mohammed anees	171291601107
70	MOHAMMED REFAIDEEN	171291601110
71	MOHANA PRIYA R	171291601111
72	MOYISUN M	171291601113
73	Mugesh Kanna S	171291601114
74	MURUGAN T	171291601116
75	Nandhini P	171291601118
76	Nasreen.s	171291601119
77	Noorul Ameen HR	171291601124
78	Pavithra.J	171291601126
79	Prabhakaran s	171291601127
80	Sanjana L	171291601128
81	Pavithra. M	171291601131
82	Pon subhasri Lakshmi N	171291601133
83	Prasanth	171291601136
84	Priyadharshini.P	171291601138



85	Rakesh K.P	171291601142
86	Rakesh M	171291601143
87	Ramyaa d	171291601145
88	Rathina Balaa R	171291601147
89	Ravi raja.N	171291601148
90	RIAZ AHMED	171291601149
91	Rubesh. T	171291601150
92	Sabari K	171291601152
93	Sairam P	171291601153
94	Salamath Nisha.A	171291601156
95	Salman baris	171291601157
96	Sanjana.B	171291601159
97	Santhya.a.k	171291601163
98	Sathish.B	171291601165
99	SATHISHKUMAR S	171291601167
100	SATHYA Narayanan.B	171291601168
101	Seethalakshmi. G	171291601170
102	Shafeeq ahmed.A	171291601171
103	SHAIK JAMEER J	171291601173
104	Shalini.S	171291601174
105	Sharan CS	171291601175
106	Sivaranjani.M	171291601177
107	Sudhakar P	171291601186
108	Vaitheeswaran A	171291601189
109	Vimal kumar.B	171291601191
110	Yuvan Shankar B	171291601192
111	Dheekshath.s	171291601193
112	HUMAYUN	171291601196
113	Sahul hameed .S	171291601198
114	Syed arif ali g	171291601201
115	Syed Nadeem F	171291601203
116	SYED SATHAK shahul hameed M N	171291601204
117	Thenmozhi I	171291601207
118	Vibisha Ramaraj	171291601208
119	Vidhya.m	171291601209
120	VIGNESH P	171291601210
121	Wasim Ahamed B	171291601212
122	yuvashree R	171291601215
123	VISHAL	171291601216
124	Abdul Mughni K.A	171411601001
125	Afrin Fathima S. A	171411601004
126	Anisha Beevi M	171411601005
127	ANUSHA R	171411601006
128	Balamuruganathan.s	171411601009
129	Bharani M	171411601010

130	Divya S	171411601011
131	Farhath Nazia . K	171411601013
132	GOPINATH N	171411601015
133	Jaganath.sp	171411601017
134	Jalal fazal kareem	171411601018
135	MADHUMITHA G	171411601019
136	Mohammed Arif A H	171411601020
137	Mohammed Fayaz	171411601021
138	MOHAMMED FAZAL	171411601022
139	Naveen V	171411601024
140	Parveen A	171411601025
141	Robert Robert	171411601029
142	SHEEBA S	171411601031
143	Sindhu. V.G	171411601032
144	Srinidhi. S	171411601033
145	SUHAIL MOHAMMED	171411601034
146	Swetha.s	171411601035
147	SYED ABU THAHIR	171411601036
148	Unes J	171411601037
149	Sarathkumar.Y	171411601040
150	Vishnu Priyan	171411601040
151	Yasodha.A	171411601041
152	Swetha A	171411601043

3. Salient Features of the Visit

3.1 Kerala: The God' own country

Kerala is situated in the southwestern end of the Indian subcontinent. Kerala has a long history of art and cultural heritage and foreign trade with other countries. The state with the highest literacy rate in India, is noted for its achievements in education, health, gender



Fig 2: A beautiful view of sea with boat and palm trees

equality, social justice, law and order. In addition to these, the state has the lowest infant mortality rate in the country.

Kerala lies between the Arabian Sea in the West and the Western Ghats (Sahyadris) in the East with an area of 38863 sq km. It is one of the five states in the linguistic-cultural area known as South India. The neighbouring states of Kerala are Tamil Nadu and Karnataka. Mayyazhi (Mahe / Mahe) is a part of Pondicherry (Puducherry) and lies within Kerala. Though the Lakshadweeps in the Arabian Sea is part of the Union Territories, it has a close alliance with the linguistic and cultural heritage of Kerala.

3.2 Munnar – A heaven of peace and Tranquility

Set at an altitude of 6000 ft in Idukki district, Munnar was the favored summer resort of the erstwhile British rulers in the colonial days. Unending expanse of tea plantations pristine valleys and mountains exotic species of flora and fauna in its wild sanctuaries and forests aroma of spice scented cool air yes! This beautiful destination has all these and more. It's the place you would love to visit it's the place you would wish never to leave.



Fig 3: A breathtaking view of Munnar with tea garden

Munnar is such a beautiful place in Kerala, which cannot be portrayed in a single canvas. Everything and anything here will make us excited. The hills, the mist, the valleys, the streams, the waterfalls, tea plantations, rare flora and fauna.... It is a beautiful tea town in Idukki district of Kerala easily accessible from Kochi and Coimbatore. The gorgeous hill station is ideally placed in the South Western Ghats of India. With an area of around 557 sq km, Munnar in Devikulam Taluk is the largest panchayat in Kerala.

Munnar is always synonymous to tea plantation. A trip to Munnar will be incomplete without having a visit to these tea plantations. Munnar is a place known for its beautiful tea estates and tea cultivation. No one will return home without tasting or shopping the tea essence of Munnar.

3.3 A Visit to Kitex Company

A part of the renowned Anna-Kitex group of companies, founded by the legendary Late Shri M. C. Jacob, Kitex Garments Ltd is the largest employer in private sector in the state of Kerala. It is located near Kochi and has easy access to sea and air ports. The company was established in 1992. With unmatched global connections, this company caters to prominent and renowned conglomerates in USA and Europe.

The company currently employs over 5000 people at its facility, and has been a business provider to many satellite businesses in the state. Having started with INR 1.8 Crores turnover in the year 1995-96, the company has now grown to a turnover of over INR 524 Crores in 2014-15.



Fig 3: Participants in front of the KiteX Limited: a tea garment manufacturing company

The company is currently the second largest producer of children's apparel in the world, and is now in the process of setting up operations in the United States of America.

3.4 Kochi (Cochin)

Kochi (also known as Cochin) is a city in southwest India's coastal Kerala state. It has been a port since 1341, when a flood carved out its harbor and opened it to Arab, Chinese and European merchants. Sites reflecting those influences include Fort Kochi, a settlement with tiled colonial bungalows and diverse houses of worship. Cantilevered Chinese fishing nets, typical of Kochi, have been in use for centuries.



Fig 5: Faculty members enjoying on the boat at Marine Drive, Kochi



Fig 6: Participants at Wallara water fall

4. Outcome of the Industrial Visit

The group had left from Chennai on 13th October 2019 afternoon for Kerala by train and reached on 14th morning. It was a great industrial trip both from educational and recreational point of view. All the destinations (Kochi, Munnar, Allaphuza) provided some kind of learning to all the students. On the same day, the group left for the visit to Lulu Mall and meet mall's management team and Mr. Shibu Thomas who made the students understand the contrast between the North Indian and South Indian retail business.

The visit on 15th October 2019 students had excursions to the tea manufacturing process and tea garden. In the evening we all enjoyed the performance of traditional Kerala Martial art,

Kalaripayattu which was very mesmerizing. The students also enjoyed a bonfire in Munnar to beat the cold weather.

Learning, fun, photographs, selfies, sweet memories were the takeaway from the trip. We came back from Kerala to Chennai and then back to our university campus on 16th October, 2019 morning.

II. **Ooty: an Industrial Visit (17-18 Oct. 2019)**

1. Preamble

Ooty is a town in the Niligiri District of Tamil Nadu. It is located 86 km north of Coimbatore and 128 km south of Mysore and is the headquarters of the Nilgiris district. It is a popular hill station of India.

Originally occupied by the Toda people, the area came under the rule of the East India Company at the end of the 18th century. The economy is based on tourism and agriculture, along with the manufacture of medicines and photographic film.



Fig 1: a beautiful view of Botanical garden, Ooty



Fig 2: The students and faculty members after arrival in Ooty

Ooty is situated in the Nilgiri Biosphere Reserve. Many of the forested areas and water bodies are off-limits to most visitors in order to protect this fragile ecosystem. Some areas of the Biosphere Reserve have been earmarked for tourism development, and steps are being undertaken to open these areas to visitors whilst conserving the area.^[23] It is situated at an altitude of 2,240 metres.

2. List of the Names of Participants

2.1 List of the Names of Faculty Members

S.No	Staff Name	Designation
1	Dr. Nirmala. S.S	Assistant Professor
2	Dr. Kogila. N	Assistant Professor
3	Dr. Mohsin Khan	Assistant Professor
4	Dr. Srinivasan C.	Assistant Professor
5	Mr. Showkat Ahmad Busru	Assistant Professor
6	Mr. Asan Bawa	Assistant Professor
7	Dr. Vijayakumar N.	Assistant Professor
8	Dr.A. Harikumar	Assistant Professor
9	Mr.Mohamed Haris.O	Assistant Professor (Full time VF)

2.2 List of the Names of Students

S.No.	Name	RRN
1	Aakamksha. S	181291601001
2	Aarthy. S	181291601003
3	Abbas Ali. Y	181291601004
4	Abdul Rahman Sharafath	181291601008
5	Aishwarya. B	181291601011
6	Ajeesh Ali. N	181291601012
7	Ajith Kumar. S	181291601013
8	Akash. R	181291601014
9	Alameen. A	181291601016
10	Anbarasan. K	181291601018
11	Aravindan. K	181291601022
12	Aravindan. R	181291601023
13	Aravindar. N	181291601024
14	Arun Kumar. A	181291601029
15	Arun Kumar. J	181291601030
16	Arun Kumar. S	181291601031
17	Arun Vignesh. M	181291601032
18	Arunachalam. T	181291601033
19	Ayas Ahamed. S	181291601035
20	Balaji. M	181291601037
21	Balamurugan. V	181291601038
22	Balkis Bee. S	181291601040
23	Barath. D	181291601041
24	Bhavani. D	181291601043
25	Bhuvanesh. S	181291601044
26	Brindha. K	181291601045
27	Christopher. A	181291601046
28	David Raj. J	181291601047
29	Deepak Kumar. S	181291601048
30	Deepak P	181291601049
31	Deepak. K	181291601050
32	Deepika. V	181291601053
33	Devadharshini. J	181291601054
34	Dhanalakshmi. P	181291601055
35	Dhanalakshmi. S	181291601056
36	Dharshini. T	181291601057
37	Dhivya Christy. R	181291601058
38	Dillibabu. K	181291601059



39	Dillieeswari. R	181291601060
40	Dinesh. P	181291601063
41	Farheen Munvarudeen	181291601067
42	Firdous Banu. N. D	181291601068
43	Gajalakshmi. J	181291601069
44	Ganashree. V	181291601070
45	Ganesan	181291601071
46	Gnana Jenin. G	181291601073
47	Gopinath. S	181291601074
48	Gowtham. M	181291601076
49	Hariharan. P	181291601079
50	Hariharan. S	181291601080
51	Harine. S	181291601081
52	Hariprasath. S	181291601082
53	Harish. A	181291601084
54	Harsha. U	181291601086
55	Hashim Ibrahim. B	181291601087
56	Hema Priya. R	181291601089
57	Hemamalini. M	181291601090
58	Imran. S	181291601092
59	Imthiyas Ahamed	181291601093
60	Infant Brittan. A	181291601094
61	Jabez Sundar Singh. R	181291601096
62	Jacob Daniel. A	181291601097
63	Jaffar. S	181291601098
64	Jagadeesh. A	181291601099
65	Jagadeesh. D	181291601100
66	Jagan. P	181291601101
67	Jamal Mohammed. M	181291601102
68	Janani. B	181291601104
69	Jawahar. R	181291601106
70	Jayashree. S	181291601108
71	Jeeva Venkatesh. S	181291601109
72	Jeevitha. S	181291601111
73	Jena. J.K	181291601112
74	Kanzool. M	181291601114
75	Karthikeyan. E	181291601115
76	Kasthuri. S	181291601116
77	Keerthika. M	181291601118
78	Kiruthika Lakshmi. J	181291601119
79	Kiruthika. M	181291601120
80	Kishore. V	181291601122
81	Krishnakishore. N	181291601123



82	Lavanya. G	181291601125
83	Logachandar. K	181291601127
84	Logesh. C	181291601128
85	Madhavan. G	181291601130
86	Madhesh. M	181291601131
87	Madheshwaran. S	181291601132
88	Madhumitha. M.R	181291601133
89	Magesh. N	181291601134
90	Mahalakshmi. N.J	181291601135
91	Maideen Beevi	181291601137
92	Mani. D	181291601138
93	Manikandan. M	181291601139
94	Maria Fastina. M	181291601142
95	Megalavathi. R	181291601143
96	Mohamed Arif Hussain. H	181291601145
97	Mohamed Basith. J	181291601146
98	Mohamed Faj Ali. S	181291601150
99	Mohamed Irban. S	181291601152
100	Mohamed Jaasir. T.H.	181291601153
101	Mohamed Mahadhir. V.N	181291601154
102	Mohamed Misfer	181291601155
103	Mohamed Mubin. M	181291601156
104	Mohamed Salman. J	181291601162
105	Mohamed Sameer. M	181291601163
106	Mohamed Shifa. M	181291601164
107	Mohamed Suhail Ali	181291601165
108	Mohamed Zuhail. M	181291601168
109	Mohammed Ashik. A	181291601169
110	Mohammed Nazeer. M	181291601172
111	Mohammed Rafi. M	181291601173
112	Mohammed Razik. H	181291601174
113	Mohammed Rhiswan. M	181291601175
114	Mohammed Riyaz. R	181291601176
115	Mohammed Salmon. N	181291601177
116	Mohammed Siddiq. S	181291601179
117	Mohammed Thoufeeq	181291601181
118	Monesh. M	181291601183
119	Mugundha Priya. N	181291601184
120	Murali. R	181291601185
121	Nadar Jayalakshmi Arulraj	181291601186
122	Najmudeen. A	181291601187
123	Nandhini. D	181291601188
124	Nandhini. L	181291601189



125	Nanthakumar. S	181291601190
126	Nasrin Kamroon. A	181291601192
127	Nishitha. N	181291601193
128	Niyaz Khaan. M	181291601195
129	Pavithra. R	181291601197
130	Prasanna Venkatesh. K	181291601201
131	Prasanna. M	181291601202
132	Prasath. M	181291601203
133	Praveena Mary	181291601205
134	Praveena. M	181291601206
135	Preethi. M	181291601207
136	Prisilla Mercy. P	181291601208
137	Purvaja.G	181291601210
138	Rajesh Kumar. P.S	181291601214
139	Rakesh. G	181291601215
140	Ranjith. B	181291601217
141	Rekha. H	181291601218
142	Roshini. S	181291601221
143	Saifullah. S	181291601223
144	Sajiya Banu. S	181291601225
145	Sameer Ahamed. J	181291601227
146	Samsudeen. J	181291601230
147	Santhiya. L	181291601235
148	Santhosh. U	181291601237
149	Saranya. P	181291601238
150	Sasikala. R	181291601241
151	Sethupathi M	181291601242
152	Shaanjai. D	181291601243
153	Shaik Rasheeth. M	181291601245
154	Shaistha Farheen. F	181291601246
155	Shalini. D	181291601247
156	Sharan Raj. S	181291601248
157	Sharan. G	181291601249
158	Sharanya. U	181291601250
159	Sharif. K	181291601251
160	Shariqa Tabassum. Z	181291601252
161	Sharmi. C	181291601253
162	Sharmila. R	181291601254
163	Shofiya. D	181291601257
164	Shri Ramana Rishi. R	181291601259
165	Shridhar. H	181291601260
166	Siddique. P.K.	181291601261
167	Siva Kumar. V	181291601262



168	Ahmed. U.K	181291601263
169	Ayesha Mariam	181291601266
170	Bhuvan Roshani	181291601267
171	Dinesh Kumar. C	181291601269
172	Inbarasu. R	181291601271
173	Iram Nadeem	181291601272
174	Kaviya. P	181291601273
175	Lakshmi. E	181291601276
176	Mohamed Fazil. N	181291601277
177	Mohamed Ubaidulla Khan	181291601278
178	Renuka. K	181291601282
179	Sanjai. S	181291601284
180	Shyamala. T	181291601285
181	Sifnas Begam. T	181291601286
182	Solairaj	181291601287
183	Soorya Prakash. G	181291601289
184	Soundharya. V	181291601290
185	Sruthi. R	181291601292
186	Sruthi. Y	181291601293
187	Surya Kumar. P	181291601296
188	Surya. L	181291601297
189	Swetha. R	181291601298
190	Tamilselvan. D	181291601300
191	Tanveer Unissa. R	181291601302
192	Thameem Ansari	181291601303
193	Ukkash Ali. S	181291601306
194	Vaishali. S	181291601307
195	Varsha. R	181291601308
196	Varun Kumar. L	181291601309
197	Vasanth. B	181291601310
198	Veerajothi. U	181291601312
199	Vengadeshwaran. K	181291601313
200	Venkat Karthick, M	181291601314
201	Vignesh. K	181291601315
202	Vignesh. S	181291601316
203	Vigneshwaran. B	181291601317
204	Vigneshwaran. R	181291601318
205	Vigneshwari. S	181291601320
206	Vijay. S	181291601322
207	Vinitha Sri. J	181291601323
208	Vishnu Priya. R	181291601324
209	Yamuna Sree. G	181291601325
210	Yashwanth. V	181291601326



211	Yogesh. K	181291601327
212	Yugendar. J	181291601328
213	Yukenthran. P	181291601329
214	Yuvaraj. G	181291601330
215	Yuvaraj. S	181291601331
216	Bharath. K	181411601011
217	Bharathi Michala Babu	181411601012
218	Bhavan Kaviyarashan	181411601013
219	Bhuvaneshwari. K	181411601014
220	Epsiba. B	181411601017
221	Harish. R	181411601023
222	Kalaisen. S	181411601028
223	Kameshwar. P.M	181411601029
224	Karthik. K	181411601030
225	Keerthana. S	181411601031
226	Kishore. S	181411601035
227	Mohamed Ibrahim. S	181411601045
228	Nandagopala	181411601050
229	Kashav Bhathra	181411601119
230	Dhuwahar. E	181411601055
231	Diana Elizebeth. R.D	181411601056
232	Mohamed Asif H	181411601059
233	Mohamed Ibrahim Sadiq	181411601060
234	Muhammad Imran. M	181411601065
235	Palavesakaran. K	181411601066
236	Prasanth. R	181411601068
237	Rafeena Raja. R	181411601069
238	Revathi. R.A	181411601077
239	Roshan Jacob. J	181411601078
240	Saiprasath. S	181411601081
241	Shabana. A	181411601086
242	Srivatsan. K	181411601091
243	Subhiksha. R	181411601095
244	Suruthi. R	181411601098
245	Swetha. S	181411601100
246	Tharini. V	181411601102
247	Thawfick Sulthan. M	181411601103
248	Thomas. K	181411601104
249	Vishnu Prasath. V	181411601109
250	Yeshwanthi. T	181411601111
251	Sri Lakshmi. B.V	181411601114
252	Nithin. K.R	181411601118
253	Mohideen Mubarak. V.M.H	181411601120

3. Salient Features of the Ooty Industrial Visit

4.1 Ooty Botanical Garden

The Government Botanical Garden is a botanical garden in Udthagamandalam, near Coimbatore (Ooty), Tamil Nadu state, India laid out in 1848. The Gardens, divided into several sections, cover an area of around 55 hectares, and lie on the lower slopes of Doddabetta peak. The garden has a terraced layout. It is maintained by the Tamil Nadu Horticulture Department.



Fig 3 : The Ooty Botanical Garden, Tamil Nadu

It ascends the slopes of the hill at an elevation of 2250–2500 metres above Mean Sea Level. The garden enjoys a temperate climate, with an average rainfall of 140 cm, the most of which is received during south-west monsoon, with frosty nights from November to February. The maximum and minimum temperatures are 28 °C and 0 °C respectively.

3.2 Doddabetta Tea Factory

Doddabetta Tea Factory, at ooty, TamilNadu was founded in the year 2005, and is well managed by Mr. N.K.Krishnamoorthy, former Member of Tea Board. Factory sprawls over an area of 1 acre in Ooty in the midst of the many blue hills of the Nilgiris, second largest hill station, bounded by tea plantations, at an altitude of 1839 meters. Its production capacity is 30 tonnes per month.



Fig 4: The Doddabetta factory



Fig 5: Participants in tea factory

Having about 35 years of experience in Tea field operations has passion to set a Tea Museum adjacent to the Dodabetta Tea Factory. As per his desire, he established the Tea Museum on 1 acre at Ooty.



Fig 6: Tea manufacturing Unit of Tea Factory

4. Outcome of the Industrial Visit

The students visited the Tea factory and the museum and got to know many interesting facts relating to the process of manufacturing Tea and all other related aspects of selling and distribution. The students were provided facility for purchasing different varieties of tea.

The group also visited the chocolate factory where they got exposure how is the manufacturing world in practical. How do the different department work for the accomplishment of the goal of the organization?



5. Certificate Provided by Doddabetta Tea Factory

Doddabetta Tea Factory And the Tea Museum



INDUSTRIAL VISIT CERTIFICATE

This is to certify that students of DEPARTMENT OF COMMERCE,
B.S. ABDUR RAHMAN CRESCENT INSTITUTE OF SCIENCE & TECHNOLOGY
visited The Doddabetta Tea Factory and the Tea Museum on 17.10.2019.
They were given first hand information of the entire tea history and processing.
They participated in a guided factory tour in which the history of tea and the
different stages of tea processing like withering, crushing, cutting / tearing /
curling (CTC), shaping, fermentation, drying, cleaning and grading was
explained to them. The students evinced keen interest in knowing all aspects
about tea manufacture.

Place : **Udhagamandalam**

Date : 17/10/2019

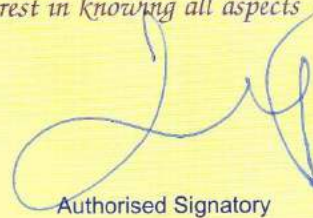

Authorised Signatory

III. A Practical Exposure of Corporate World: An Industrial Visit to Kerala (20-21 Oct. 2019)

1.Preamble

The industrial visit was for specially BBA Financial Services II year students. For this visit, we chose Kerala to observe the tea manufacturing industry, Wood factory and lemon grass oil factory. Apart from theoretical knowledge, the student must be given practical knowledge of working corporate culture and work style of various departments.

Taking into consideration the above important aspects, the industrial visits conducted, and thus we took the BBA student for the visit to Kerala after a proper permission of Registrar, Dean Academic and Head of the department.

2. List of the Names of Participants

2.1 List of the Names of Faculty Members

S.No.	Name	Designation
1	Mr. Haris (Coordinator)	Assistant Professor (V.F.)
2	Ms. Saba Khan (Escort)	Research Scholar

2.2 List of the Names of the Students

S.No.	RRN	RRN
1	Abdul Rahman .S	181491601002
2	Akashwaran M.U	181491601005
3	Ashik Ahamed.M	181491601008
4	Balaji.D	181491601009
5	Madesh.H	181491601022
6	Madhanraj.S	181491601023
7	Madhanagopal.R	181491601024
8	Mohamed Basha.J	181491601027
9	Mohamed Jackaria.M	181491601029
10	Mohamed Jaseem.A	181491601030
11	Mohamed Othman Mubeen.M	181491601034
12	Mohamed Shahiyudeen.R	181491601035
13	Mohamed.A	181491601037
14	Mohammed Asraf.J	181491601039
15	Muthuvel.S	181491601049

16	Muzammil Dheensha.J	181491601050
17	Nauman.I	181491601051
18	Rajapandi.P	181491601058
19	Shawn Hebraeq.S.H	181491601067
20	Sureshkumar.S	181491601069
21	Surya.R	181491601070
22	Syed Fizal.M	181491601071
23	Vignesh.L	181491601073
24	Aliya Rizwan	181491601006
25	Amuthini.V	181491601007
26	Devadharshini.R	181491601010
27	Karunya.T	181491601021
28	Manisha Reddy.S	181491601025
29	Monisha.N	181491601044
30	Niraimathi	181491601051
31	Prathana.B	181491601052
32	Saundarya.R	181491601065
33	Sathvika Reddy	181491601072

3. Salient features of the Industrial Visit

3.1 Timber Wood Industry

The wood market or lumber market is a-- generally personal-- financial sector interested in forestry, logging, wood trade, and the production of forest items, timber, main forest and wood items (e.g. furniture) and secondary items like wood pulp for the pulp and paper market. Some biggest manufacturers are likewise amongst the greatest timberland owners.

In the narrow sense of the terms, wood, forestry, forest and timber/lumber market appear to indicate various sectors, in the industrialized, internationalized world, there is a propensity towards big integrated services that cover the total spectrum from silviculture and forestry in personal main or secondary forests or plantations through the logging procedure as much as wood processing and trading and transportation.

Processing and items varies specifically with regard to the difference in between softwood and wood. While softwood mainly enters into the production of wood fuel and pulp and paper, wood is utilized generally for furniture, floorings, and so on. Both types can be of usage for structure and (domestic) building and construction functions (e.g. log homes, log cabins, wood framing).



Fig 1: Workers of industry while loading the timber wood logs



Fig 2: Timber wood logs

3.2 Lemon Grass Oil Industry

lemongrass plantation has a life cycle of 6 – 8 years. The oil yield reaches its maximum around the third year or fourth year and its annual average value range between 15 and 20 kg/ha with three crops per year. The ratio of lemongrass oil to leaves is equal to 0.348%.

Features of Lemon grass oil

- It may help prevent gastric ulcers or relieve nausea.
- It has antifungal properties.
- It has anti-inflammatory properties.

It has antioxidant properties



Fig 3: Lemon grass oil production unit made up of clay soil



Fig 4: Participants relaxing at fruit farming village

4. Outcome of the Industrial Visit

The students visited the Wood factory, lemon grass oil production and fruit farm got to know the importance of the food and also the hard work behind the production and all other related aspects of selling and distribution. The students were provided facility for purchasing different varieties of tea, oil and fresh fruits.

- Understanding the importance of working as a team.
- Developing interpersonal skills.
- Understanding conflict resolution and team building.

The group also visited the chocolate factory where they got exposure how is the manufacturing world in practical. How do the different departments work for the accomplishment of the goal of the organization?

Field Visit Co-ordinators

1. Ms. Farzana S
2. Ms. Ifra Fathima I.
3. Dr. Nirmala. S.S
4. Dr.A. Harikumar
5. Mr. Mohamed Haris



2/11/19
PROFESSOR & HEAD
Department of Commerce
B.S. Abdur Rahman
Crescent
Institute of Science & Technology
Vandalur, Chennai-600 048

HOD Commerce



B.S. Abdur Rahman

Crescent

Institute of Science & Technology

Deemed to be University u/s 3 of the UGC Act, 1956

Department of Aerospace Engineering

Internship based on UAV and drone technologies.

Aviocian Technologies Private Limited

New Delhi

Duration: 5th January 2019 to 25th January 2019

No of students: 4

Unmanned Aerial Vehicle (UAV)

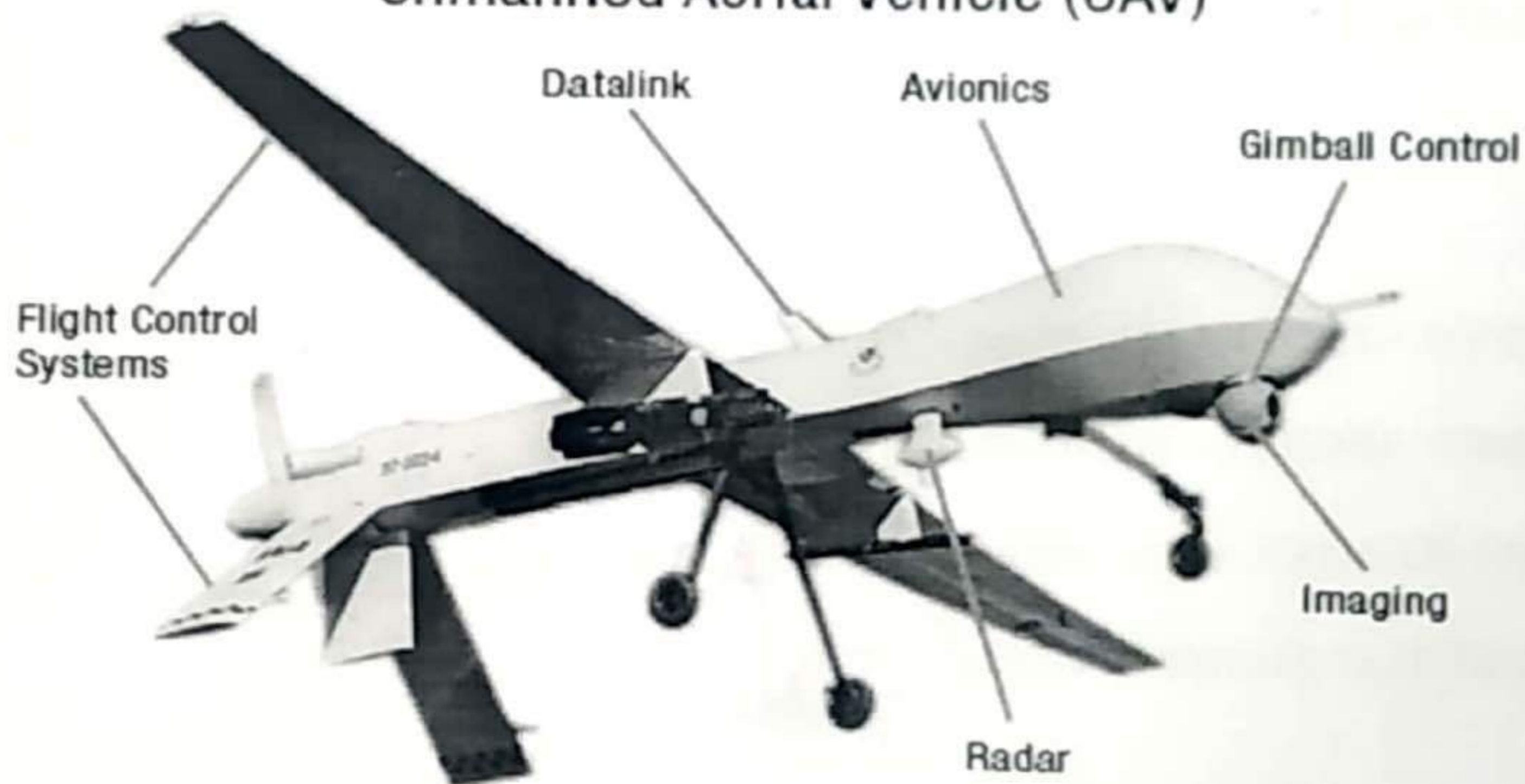

WEIGHT WEIGHING:

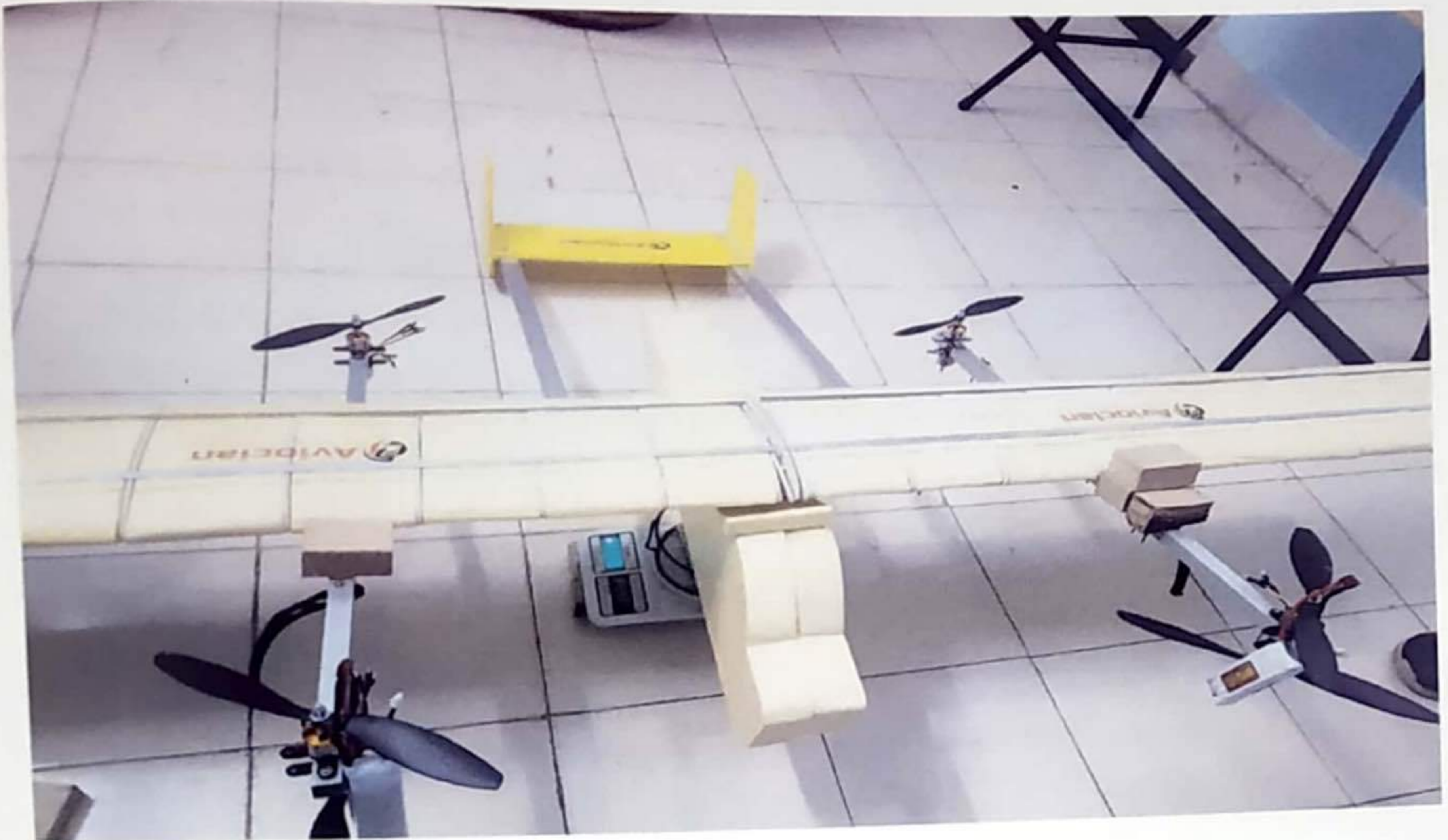

FINISHED DESIGN:

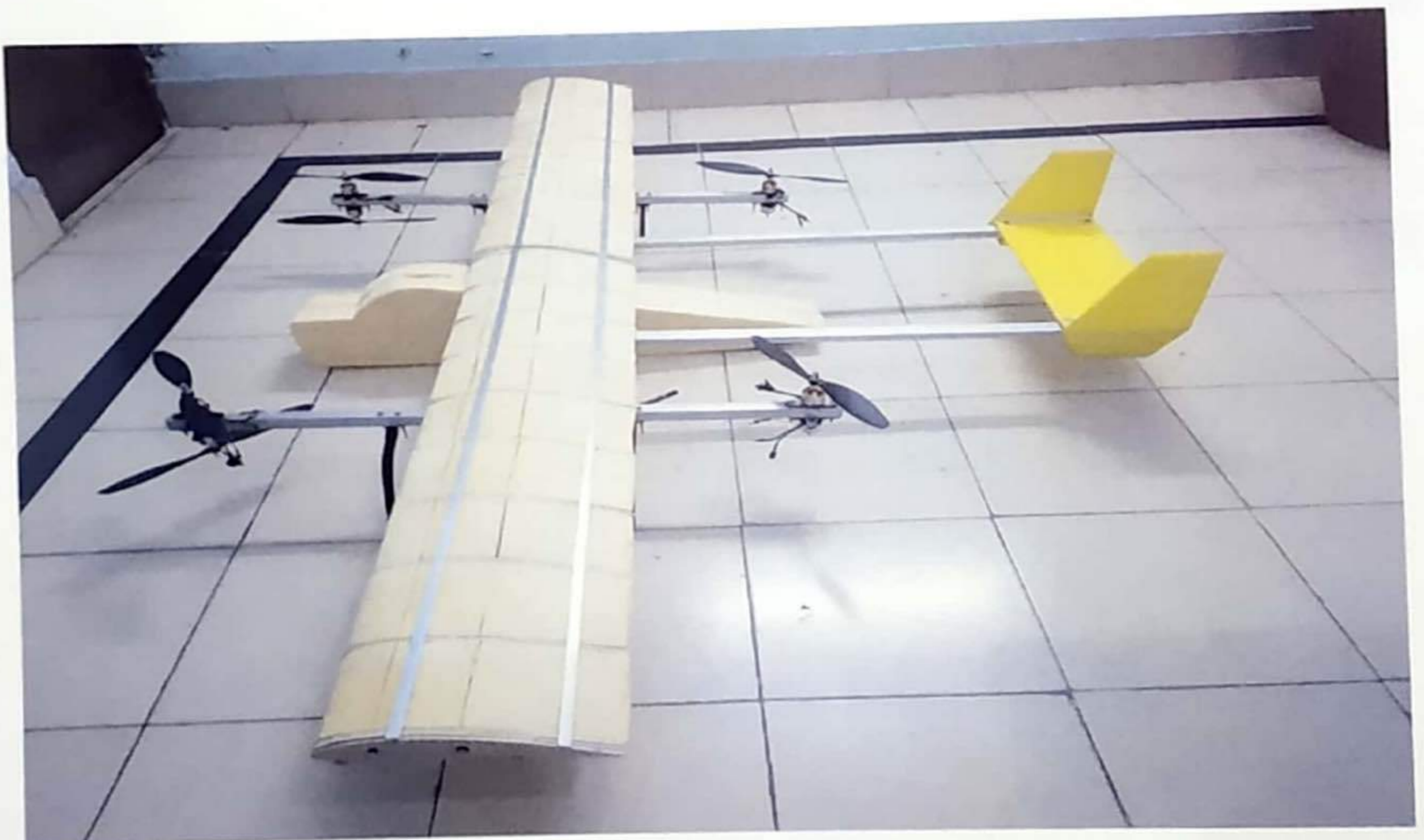

REPORT ON INTERNSHIP

SUMMARY:

It was a tremendous experience that was availed with devotion and commitment. But one thing we want to share is that it is not easy as it looks. Though there were difficulties and complications in the process, it was nice and great. This internship taught us a lot. Being in Delhi for a month and leading a bachelor life, cooking food and living a life on our own was new to us. It was fun and all those funs taught us of things. But, at the end of the day, the outcome was that we learnt fabrication of hybrid UAV and a few more lessons that are and will be important for the life that we live and are yet to lead.

CONCLUSION:

It was a complete useful experience working at the Aviocian Technologies pvt.ltd at New Delhi. The friendly welcoming staff and the space they created for us allowed us with full opportunities to learn and know myself as a worker. This experience brought out our strength and also the area we needed to make up. It added more confidence to our professional approach built a stronger positive attitude and taught us how to work in a team as a player. The primary objective of our internship is to gather a real-life working experience and put our theoretical knowledge in practice.

As a human being we noticed many changes in our attitude. we are more confident and more likely to do any work.

During our training we thoroughly enjoyed the challenges that came along every single day. We learned that this is just the beginning of the road and we have to travel a long distance to be a successful person in this field. This experience will prove an objective in our career.



HOD/ Aerospace Engg.

Department of Aerospace Engineering
B.S. Abdur Rahman
Crescent
Institute of Science & Technology
Vandalur, Chennai-800 048.

14th February, 2019

TO WHOM IT MAY CONCERN

This is to certify that Mr. SANGEETH KUMAR.S a student of Crescent Institute of Science and Technology, Chennai, Tamil Nadu, India has successfully completed the internship program from 5th January 2019 to 25th January 2019 at Aviocian Technologies Private Limited, New Delhi. He has satisfactorily worked on the project "Design and Development of Hybrid UAV" During the internship period he was found to be punctual, hardworking and creative in his approach.

We wish him all the very best in his future endeavors.

Yours Sincerely,

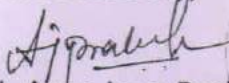

A.J. Arun Jeya Prakash

Co-Founder & CEO

Aviocian Technologies Pvt. Ltd.

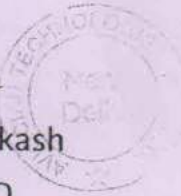

14th February, 2019

TO WHOM IT MAY CONCERN

This is to certify that Mr. NANDA KUMAR.G a student of Crescent Institute of Science and Technology, Chennai, Tamil Nadu, India has successfully completed the internship program from 5th January 2019 to 25th January 2019 at Aviocian Technologies Private Limited, New Delhi. He has satisfactorily worked on the project "Design and Development of Hybrid UAV" During the internship period he was found to be punctual, hardworking and creative in his approach.

We wish him all the very best in his future endeavors.

Yours Sincerely,

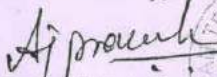

A.J. Arun Jeya Prakash

Co-Founder & CEO

Aviocian Technologies Pvt. Ltd.





AVIOCIAN TECHNOLOGIES PRIVATE LIMITED

125/13 Amrit Puri East of Kailash, New Delhi

Pin Code- 110065

Phone No.: +91-8810538822

Email: info@aviociantech.com, aviociantech@gmail.com

Website: www.aviociantech.com

14th February, 2019

TO WHOM IT MAY CONCERN

This is to certify that Mr. NAGOOR MEERAN.A a student of Crescent Institute of Science and Technology, Chennai, Tamil Nadu, India has successfully completed the internship program from 5th January 2019 to 25th January 2019 at Aviocian Technologies Private Limited, New Delhi. He has satisfactorily worked on the project "Design and Development of Hybrid UAV" During the internship period he was found to be punctual, hardworking and creative in his approach.

We wish him all the very best in his future endeavors.

Yours Sincerely,

A handwritten signature in black ink, appearing to read 'Arun Jeya Prakash'.

A.J. Arun Jeya Prakash

Co-Founder & CEO

Aviocian Technologies Pvt. Ltd.





AVIOCIAN TECHNOLOGIES PRIVATE LIMITED

125/13 Amrit Puri East of Kailash, New Delhi

Pin Code- 110065

Phone No.: +91-8810538822

Email: info@aviociantech.com, aviociantech@gmail.com

Website: www.aviociantech.com

14th February, 2019

TO WHOM IT MAY CONCERN

This is to certify that Mr. MOHAMED AFRIDH.A a student of Crescent Institute of Science and Technology, Chennai, Tamil Nadu, India has successfully completed the internship program from 5th January 2019 to 25th January 2019 at Aviocian Technologies Private Limited, New Delhi. He has satisfactorily worked on the project "Design and Development of Hybrid UAV" During the internship period he was found to be punctual, hardworking and creative in his approach.

We wish him all the very best in his future endeavors.

Yours Sincerely,

A handwritten signature in black ink, appearing to read "A.J. Arun Jeya Prakash".

A.J. Arun Jeya Prakash

Co-Founder & CEO

Aviocian Technologies Pvt. Ltd.





LANSON TOYOTA

34, Poonamallee High Road,
Koyambedu, Chennai - 600 107.

Sales & Service: 4000 8000

Fax : 3960 5072

To
The HOD,
BS ABDUR RAHMAN CRESCENT INSTITUTE OF SCIENCE & TECHNOLOGY
Vandalur
Chennai - 600 048

Sub: Permission to do Internship.

Dear Sir,

I am pleased to confirm the Internship for **Mr. R. NITISH (Reg.No:170121601037)** II year B.Tech Automobile Engineering in our organization at **KOYAMBEDU** Unit from **15th December 2018 to 22nd December 2018.**

During the said period the student will not be eligible for any stipend or other benefits and will be governed by the Rules and Regulations of our organization.

A copy of the Internship report has to be submitted to us at the end of the tenure.

Form Lanson Motors Private Limited.

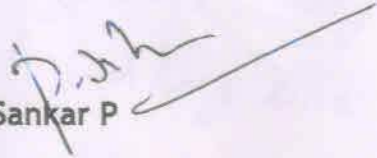
Sankar P

Group Head- Human Resource

Volkswagen Coimbatore



Ramani Cars Private Limited, 54/1, Mettupalayam Road, Kavundampalayam, Coimbatore - 641030.
CIN NO IS: U50101TZ2009PTCO15058

07.01.2019

Date

TO WHOM SO EVER IT MAY CONCERN

This is to certify that **Mr. A. Karthick Akaash (150121602004)**, Student of Present Engineering Collage, Chennai has undergone his Internship Training in our concern during the period from 24.12.2018 to 02.01.2019.

He has been regular and shown keen interest in the assignment and his conduct and character were good.

We wish him all the best for future endeavor.

Volkswagen Coimbatore

Ramani Cars Private Limited,

54/1, Mettupalayam Road,

Kavundampalayam,

Coimbatore - 641030.

Phone 91 - 422 - 4600000

Email: sales@vw-ramanicars.co.in

Web: www.vw-ramanicars.co.in

CIN NO IS: U50101TZ2009PTCO15058

Unit Certified By EMS

Ramani Cars Private Limited

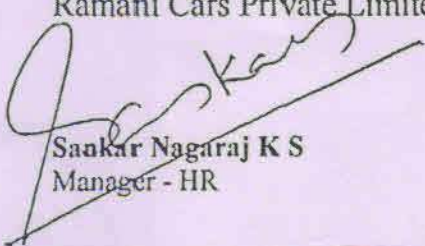
Saakar Nagaraj K S
Manager - HR

Volkswagen Tirunelveli



Ramani Cars Private Limited, 380/3B1J, Malliha Colony, Madurai to Nagerkovil 4 way, Near Rettiarpatti Hills, Maharaja Nagar (PO), Tirunelveli-627011.

Date

30.06.18

TO WHOM SO EVER IT MAY CONCERN

This is to certify that Mr. Ashwin Karthikeyan. B.E. Mechanical engineering student of .B.S Abdur Rahman Crescent of Science & Technology Technology has undergone his Internship Training during the period from 01.05.2018 to 30.06.2018.

Volkswagen Tirunelveli
Ramani Cars Private Limited,
380/3B1J, Malliha Colony,
Madurai to Nagerkovil 4 way,
Near Rettiarpatti Hills,
Maharaja Nagar (PO),
Tirunelveli-627011.
Phone 91-462-3014000

Those has been regular and shown keen interest in the assignment and his conduct and character were good.

We wish him all Success in his Future endeavors.

VW Ramani Cars Pvt. Ltd.

B.M Senthil Kumar, 20/09/2018

Service Manager



RENAULT
Passion for life

DATE : 11/01/2019

CERTIFICATE

This is to certify that **Mr.R.ASHWIN KARTHIKEYAN** has worked as intern in **ARASPVPV AUTOMOBILES PVT LTD** as technician from **07/01/2019 to 11/01/2019** for a period of **5 days**. During this period his **Conduct and Character was Good.**

For AR.A.S.P.V.P.V.AUTOMOBILES PVT LTD

MANAGER- SERVICE



RENAULT Tirunelveli
AR.A.S.P.V.P.V. Automobiles Private Limited
10-D, Trivandrum Road, Palayamkottai, Tirunelveli - 627002
Tel : 0462 - 2501355
E-mail : sales.tirunelveli@renault-india.com

Volkswagen Madras

KUN Capital Motors Private Limited

CIN No. : U74900TN2013PTC092125



20-Jul-2019

TO WHOMSOEVER IT MAY CONCERN

This is to certify that Student **Mr. Anantha Krishnan**, (Reg No: 170121601003) – B.Tech (Second Year), Batch 2017-2021 in Crescent Institute of Science & Technology, Vandalur, Chennai-48 has successfully completed the Internship training in our Organization from 26th June 2019 to 12th July 2019.

During the period, he was eager to learn and was sincere to his Assignments.

We wish him the very best for his bright future.

For KUN Capital Motors Pvt Ltd

Authorized Signatory



Feedback

31-1-19.

From

A. Karthick Akaash.

Department of automobile engineering

B.S Abdur rahman crescent institute
of science and technology

vandalur

Chennai - 600048.

To,

The head of the department.

Department of automobile engineering

B.S Abdur rahman crescent institute
of science and technology.

vandalur

Chennai - 600048.

Respected Sir.

Sub:- Regarding Internship.

In holidays I have done the internship in Volkswagen coimbatore (24-12-18 to 2-1-19). I have learnt many works like wheel alignment, Radiator cleaning, Removal of water pump, dismantling of gear box, AC vent cleaning, working of ABS sensors and so on. It's very useful to learn and work in the company. In subjects we learnt Automotive transmission, Automobile chassis are very useful in theory courses.

yours truly

A. Karthick Akaash

From,

R. Nitish

Department of automobile engineering

BS Abdul Rahman Crescent University

Vandaloor

Chennai - 600 048

To,

The head of the Department

Department of automobile engineering

BS Abdul Rahman Crescent Institute of Science & Technology

Vandaloor

Chennai - 600 048

Sub: Regarding Internship

Respected Sir,

In holidays, I have done the internship in Toyota Chennai (15-12-2018 to 22-12-2018). I have learnt many servicing works and concepts and working like Gearbox, Propeller shaft, Differential, etc. It is very useful to learn and work in the company.

Yours truly

R. Nitish

LANSON MOTORS PRIVATE LIMITED

INTERNSHIP REPORT

DURATION : 15.12.2018 to 22.12.2018

LOCATION : CHENNAI

REPORT BY

R NITISH

RR NO.170121601037

CRESCENT INSTITUTE OF SCIENCE & TECHNOLOGY

REPORT TO

MR. ROVIN CHARLES DANIEL

SENIOR EXECUTIVE - HR

LANSON MOTORS PRIVATE LIMITED

HEAD OF THE DEPARTMENT

AUTOMOBILE

**CRESCENT INSTITUTE OF SCIENCE &
TECHNOLOGY**



**BS ABDUR RAHMAN CRESCENT UNIVERSITY
VANDALUR, CHENNAI.**

Report on internship Carried out at

KUN VOLKSWAGEN



From 27st June, 2019 to 13th July, 2019

Academic Year 2018-2019

Department of Automobile Engineering

ANANTHAKRISHNAN S.P.

ARUNKUMAR P

DHANUSH S

GOPALAKRISHNAN S

REHMANBASHA W



HR/IPT/ 2019
June 21, 2019

TO WHOMSOEVER IT MAY CONCERN

This is to certify that Mr.M.Abhineshjayram, B.Tech(EIE), II year, RRN: 170061601001, student of Crescent Institute of Science & Technology , Vandalur has undergone In-Plant training in our Organization from June 19, 2019 to June 21, 2019 to understand the process of IC Assembly, Packaging, Testing and other Commercial Functions.

For SPEL Semiconductor Limited

N.J.Chandrasekar
Vice President (Quality & HR)

5 CMDA Industrial Estate
MM Nagar (Chennai) 603 209, India
Ph : +91 (44) 4740-5300
Fax: +91 (44) 4740-5303

SPEL Semiconductor Limited

CIN : L32201TN1984PLC011434

eMail : info@natronix.net
Website : www.natronix.net

4030 Moorpark Ave # 236
San Jose, CA 95117, USA
Ph : +1 (408) 898-4639



HR/IPT/ 2019
June 21, 2019

TO WHOMSOEVER IT MAY CONCERN

This is to certify that Mr.I.Dennis Daniel, B.Tech(EIE), II year, RRN: 170061601006, student of Crescent Institute of Science & Technology , Vandalur has undergone In-Plant training in our Organization from June 19, 2019 to June 21, 2019 to understand the process of IC Assembly, Packaging, Testing and other Commercial Functions.

For SPEL Semiconductor Limited

N.J.Chandrasekar
Vice President (Quality & HR)

5 CMDA Industrial Estate
MM Nagar (Chennai) 603 209, India
Ph : +91 (44) 4740-5300
Fax : +91 (44) 4740-5303

SPEL Semiconductor Limited

CIN : L32201TN1984PLC011434

eMail : info@natronix.net
Website : www.natronix.net

4030 Moorpark Ave # 236
San Jose, CA 95117, USA
Ph : +1 (408) 898-4639



HR/IPT/ 2019
June 21, 2019

TO WHOMSOEVER IT MAY CONCERN

This is to certify that Mr.S.Goutham, B.Tech(EIE), II year, RRN: 170061601008, student of Crescent Institute of Science & Technology , Vandalur has undergone In-Plant training in our Organization from June 19, 2019 to June 21, 2019 to understand the process of IC Assembly, Packaging, Testing and other Commercial Functions.

For SPEL Semiconductor Limited

N.J.Chandrasekar
Vice President (Quality & HR)

5 CMDA Industrial Estate
MM Nagar (Chennai) 603 209, India
Ph : +91 (44) 4740-5300
Fax : +91 (44) 4740-5303

SPEL Semiconductor Limited

CIN : L32201TN1984PLC011434

eMail : info@natronix.net
Website : www.natronix.net

4030 Moorpark Ave # 236
San Jose, CA 95117, USA
Ph : +1 (408) 898-4639

student report

IN-PLANT TRAINING

NAGMAN INSTRUMENTS

CHEMBARAMBAKKAM, CHENNAI 600 123

time period 5 days

organizers Dr. D. Najumnissa Jamal; Mr. S. Shahul Hamid

Abhishek . R

160061601001

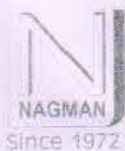

Nagman Instruments and Electronics Private Ltd.

COMPREHENSIVE CALIBRATION SOLUTIONS

- thro' Standards, Systems, Packages, Software and Services

Nagman Complex,
27th KM Stone,
Chennai-Bangalore NH-4,
Chembarambakkam,
Nazarathpet P.O.,
Chennai - 600 123,
INDIA.

Phone (Board)

+91-44-26811700
+91-44-26311702
+91-44-66777000
+91-44-66777011
+91-44-66777022
+91-44-66777033

Fax

+91-44-26811703

E-Mail

support@nagman.com

Website

www.nagman.com

CIN

U33111TN1986PTC013195

VAT TIN

33411661864

CST

53747/30,12,1986.

GST

33AAACN8390D1ZL



C-162, C-163, C-164, C-1232



AN ISO 9001:2008 COMPANY

Friday, June 28, 2019

To

**The Professor,
Electronics and Instrumentation Engineering,
BSA Crescent institute of Science and Technology,
Vandalur,
Chennai – 600 048.**

Dear Sir,

This is to certify that **Mr.Abhishek R Roll No. 160061601001** studying **Third year – B.E. Electronics & Instrumentation Engineering** in your esteemed college, has undergone In-plant Training at our works from **24th June to 28th June 2019.**

For **Nagman Instruments & Electronics (P) Ltd,**

**M.G.Ramachandran.
General Manager – Hrd.**

NATIONAL INSTITUTE OF OCEAN TECHNOLOGY



INTERNSHIP REPORT

DEEP SEA TECHNOLOGY

BY

N.MOHAMMED ASHIQ

J.ASHWINTH

V.PAVAN KUMAR

T.SHIR SABESAN



B.S. Abdur Rahman

Crescent

Institute of Science & Technology

Deemed to be University u/s 3 of the UGC Act, 1956

GST Road, Vandalur, Chennai 600 048



"Surging from the silver year in the oceans towards the golden"

राष्ट्रीय समुद्र प्रौद्योगिकी संस्थान
वेलच्चेरी - तामबरम रोड, नारायणपुरम, पल्लिकरणै, चेन्नै - 600 100, भारत.

National Institute of Ocean Technology

Velachery - Tambaram Road, Narayanapuram, Pallikaranai, Chennai - 600 100 INDIA.
फोन / Phone : 044 66783300 फैक्स / Fax : 044 22460275 GSTIN# 33AAATN05301Z6
वेबसाइट / Website : www.niot.res.in, ISO 9001 Certified Institution



सूचना का
अधिकार
RIGHT TO
INFORMATION

डॉ. एन. वेदाचलम्
Dr. N.VEDACHALAM
वैज्ञानिक एफ /मासंवि - प्रभारी
SCIENTIST- F / HRD IN-CHARGE

रासप्रौस / मासंवि / छात्र इंटरनशिप / 108 / 2019
NIOT / HRD / STUDENT INTERNSHIP / 108 / 2019

July 19, 2019

TO WHOMSOEVER IT MAY CONCERN

This is to certify Mr. M. Mohamed Ashiq, III Year, B.Tech, Degree in Electronics and Instrumentation Engineering, B.S. Abdur Rahman Crescent Institute of Science & Technology, Chennai, has successfully completed his Internship in Deep Sea Technologies Group at National Institute of Ocean Technology, Chennai during the period 19th June, 2019 to 19th July, 2019.

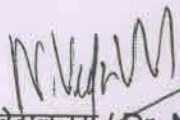
(डॉ.एन.वेदाचलम् / Dr. N. VEDACHALAM)

एचआरडी-प्रभारी
HRD-In- Charge
राष्ट्रीय समुद्र प्रौद्योगिकी संस्थान
National Institute of Ocean Technology
पृथ्वी विज्ञान मंत्रालय, भारत सरकार
Ministry of Earth Sciences, Govt. of India
पल्लिकरणै, चेन्नै-६०० १००.
Pallikaranai, Chennai - 600 100.





"Surging from the silver year in the oceans towards the golden"

राष्ट्रीय समुद्र प्रौद्योगिकी संस्थान

वेलच्चेरी - तामबरम रोड, नारायणपुरम, पल्लिकरणै, चेन्नै - 600 100, भारत.

National Institute of Ocean Technology

Velachery - Tambaram Road, Narayanapuram, Pallikaranai, Chennai - 600 100 INDIA.

फोन / Phone : 044 66783300 फैक्स / Fax : 044 22460275 GSTIN# 33AAATN05301Z6

वेबसाइट / Website : www.niot.res.in, ISO 9001 Certified Institution



सूचना का
अधिकार
RIGHT TO
INFORMATION

डॉ. एन. वेदाचलम्

Dr. N.VEDACHALAM

वैज्ञानिक एफ़ / मासंवि - प्रभारी

SCIENTIST- F / HRD IN-CHARGE

रासप्रौस / मासंवि / छात्र इंटरनशिप / 109 / 2019

NIOT / HRD / STUDENT INTERNSHIP / 109 / 2019

July 19, 2019

TO WHOMSOEVER IT MAY CONCERN

This is to certify **Mr. J. Ashwinth**, III Year, B.Tech, Degree in Electronics and Instrumentation Engineering, B.S. Abdur Rahman Crescent Institute of Science & Technology, Chennai, has successfully completed his Internship in Deep Sea Technologies Group at National Institute of Ocean Technology, Chennai during the period 19th June, 2019 to 19th July, 2019.

(डॉ. एन. वेदाचलम् / Dr. N. VEDACHALAM)

एचआरडी-प्रभारी

HRD-In- Charge

राष्ट्रीय समुद्र प्रौद्योगिकी संस्थान

National Institute of Ocean Technology

पृथ्वी विज्ञान मंत्रालय, भारत सरकार

Ministry of Earth Sciences, Govt. of India

पल्लिकरणै, चेन्नै-६०० १००.

Pallikaranai, Chennai - 600 100.



ESSO Earth System Science Organisation (Ministry of Earth Sciences, Government of India)



"Surging from the silver year in
the oceans towards the golden"

राष्ट्रीय समुद्र प्रौद्योगिकी संस्थान

वेलच्चेरी - तामबरम रोड, नारायणपुरम, पल्लिकरण, चेन्नै - 600 100, भारत.

National Institute of Ocean Technology

Velachery - Tambaram Road, Narayanapuram, Pallikaranai, Chennai - 600 100 INDIA.

फोन / Phone : 044 66783300 फैक्स / Fax : 044 22460275 GSTIN# 33AAATN05301Z6

वेबसाइट / Website : www.niot.res.in, ISO 9001 Certified Institution



सूचना का
अधिकार
RIGHT TO
INFORMATION

डॉ. एन. वेदाचलम्

Dr. N.VEDACHALAM

वैज्ञानिक एफ / मासंवि - प्रभारी

SCIENTIST- F / HRD IN-CHARGE

रासप्रौस / मासंवि / छात्र इंटरनशिप / 106 / 2019

NIOT / HRD / STUDENT INTERNSHIP / 106 / 2019

July 19, 2019

TO WHOMSOEVER IT MAY CONCERN

This is to certify **Mr. V. Pavan Kumar**, III Year, B.Tech, Degree in Electronics and Instrumentation Engineering, B.S. Abdur Rahman Crescent Institute of Science & Technology, Chennai, has successfully completed his Internship in Deep Sea Technologies Group at National Institute of Ocean Technology, Chennai during the period 19th June, 2019 to 19th July, 2019.

(डॉ. एन. वेदाचलम् / Dr. N. VEDACHALAM)

एचआरडी-प्रभारी

HRD-In- Charge

राष्ट्रीय समुद्र प्रौद्योगिकी संस्थान

National Institute of Ocean Technology

पृथ्वी विज्ञान मंत्रालय, भारत सरकार

Ministry of Earth Sciences, Govt. of India

पल्लिकरण, चेन्नै-६०० १००.

Pallikaranai, Chennai - 600 100.



ESSO Earth System Science Organisation (Ministry of Earth Sciences, Government of India)



"Surging from the silver year in
the oceans towards the golden"

राष्ट्रीय समुद्र प्रौद्योगिकी संस्थान
वेलच्चेरी - तामबरम रोड, नारायणपुरम, पल्लिकरणै, चेन्नै - 600 100, भारत.

National Institute of Ocean Technology

Velachery - Tambaram Road, Narayanapuram, Pallikaranai, Chennai - 600 100 INDIA.
फोन / Phone : 044 66783300 फैक्स / Fax : 044 22460275 GSTIN# 33AAATN05301Z6
वेबसाइट / Website : www.niot.res.in, ISO 9001 Certified Institution



सूचना का
अधिकार
RIGHT TO
INFORMATION

डॉ. एन. वेदाचलम्
Dr. N.VEDACHALAM
वैज्ञानिक एफ / मासंवि - प्रभारी
SCIENTIST- F / HRD IN-CHARGE

रासप्रौस / मासंवि / छात्र इंटरनशिप / 107 / 2019
NIOT / HRD / STUDENT INTERNSHIP / 107 / 2019

July 19, 2019

TO WHOMSOEVER IT MAY CONCERN

This is to certify **Mr. Shir Sabesan**, III Year, B.Tech, Degree in Electronics and Instrumentation Engineering, B.S. Abdur Rahman Crescent Institute of Science & Technology, Chennai, has successfully completed his Internship in Deep Sea Technologies Group at National Institute of Ocean Technology, Chennai during the period 19th June, 2019 to 19th July, 2019.

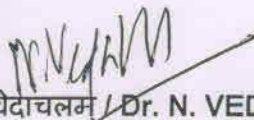
(डॉ. एन. वेदाचलम् / Dr. N. VEDACHALAM)

एचआरडी-प्रभारी
HRD-In- Charge
राष्ट्रीय समुद्र प्रौद्योगिकी संस्थान
National Institute of Ocean Technology
पृथ्वी विज्ञान मंत्रालय, भारत सरकार
Ministry of Earth Sciences, Govt. of India
पल्लिकरणै, चेन्नै-600 100.
Pallikaranai, Chennai - 600 100.



ESSO Earth System Science Organisation (Ministry of Earth Sciences, Government of India)

Report on Industrial Training in

OIL AND NATURAL GAS CORPORATION LTD.

KARAIKAL ASSET

Submitted to

Mr.Y.T.WILSON DGM (I)

By

TASLEEM BEEMA .S

**(B.S.ABDUR RAHMAN CRESCENT INSTITUTE OF
SCIENCE AND TECHNOLOGY)**

(25.06.2018-9.07.2018)



OIL AND NATURAL GAS CORPORATION LIMITED

Sl.No. CA/KK/HR/HRD/Sec.Trng/B.E. B.Tech/201-19/188

Work Centre : Cauvery Asset, Karaikal.

This is to certify that Mr./Ms. S. TASLEEM BEEMA
student of CRESCENT COLLEGE, CHENNAI
has undergone Summer/Winter/Industrial Training at ONGC from 25/06/2018 to
05/07/2018. He/She has successfully completed his/her Project Work on
INTERNSHIP / I PLANT TRAINING
in the discipline of B.TECH ELECTRONICS & INSTRUMENTATION ENGIN.
During the training, he/she took keen interest in the assigned work. We wish him/her all success in
his/her academic endeavours and life.

Date : 09/07/18

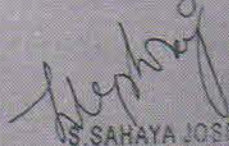
S. SAHAYA JOSEPHRAJ
MANAGER (HR & TRNG)
Co-ordinator of Training
ONGC
KARAikal - 608 604



NLC TAMIL NADU POWER LIMITED

(A Subsidiary Company of NLC Ltd, A Government of India Enterprise)

&

A JV between NLC & TANGEDCO)

Harbour Estate, TUTICORIN - 628 004.



This is to certify that Shri./kumari. Y, VARSHAN, a student of B.E. (E&I) degree IIIrd year, Roll.No. 150061601027 of B.S. ABDUR RAHMAN CRESCENT INSTITUTE OF SCIENCE AND TECHNOLOGY, CHENNAI, College/Institution, as a part fulfillment of academic curriculum, based on the bonafide certificate issued by the institution concerned has successfully completed Inplant/Internship training in C&I division in our organization from 02.01.2018 to 06.01.2018. During the Inplant /Internship training his/her involvement in training and conduct were Good.

This certificate is issued only as a proof for having undergone the said training without any further commitment whatsoever on the part of our company.

Place: TUTICORIN,

Date: 06.01.2018

HEAD OF HUMAN RESOURCE / NTPL

Deputy General Manager (HR)
NLC Tamil Nadu Power Limited
Harbour Estate, Tuticorin-628 004

**A STUDY ABOUT BASIC FIELD INSTRUMENTS
INTERNSHIP REPORT-2018**

An internship report submitted in partial fulfillment for the requirements for the award of
the degree of

BACHELOR OF TECHNOLOGY

Submitted by

ABHINESHJAYRAM M	170061601001
GOUTHAM S	170061601008
MOHAMMED ASITH N	170061601016
MOHAMED THAWFIQ S	170061601015
SHAKIL AKTHAR A	170061601023

UNDER THE GUIDANCE OF

Mrs. G.SOWMYA DCE/C&I/TPS I EXPANSION



B.S. Abdur Rahman

Crescent

Institute of Science & Technology
Deemed to be University u/s 3 of the UGC Act, 1956
GST Road, Vandalur, Chennai 600 048

**B S ABDUR RAHMAN CRESCENT INSTITUTE
OF SCIENCE AND TECHNOLOGY**

DEPARTMENT OF ELECTRONICS AND INSTRUMENTATION ENGINEERING

**B S ABDUR RAHMAN CRESCENT INSTITUTE OF SCIENCE AND TECHNOLOGY,
CHENNAI**

REPORT- 2018



CREATING WEALTH FOR WELLBEING

NLC INDIA LIMITED
'NAVRATNA' – (A GOVERNMENT OF INDIA ENTERPRISE)
NEYVELI, TAMILNADU.

CERTIFICATE

This is to certify that the internship report entitled "**BASIC FIELD INSTRUMENTS IN POWERPLANT**" is the Bonafide internship done by the following students.

ABHINESHJAYRAM M	170061601001
GOUTHAM S	170061601008
MOHAMMED ASITH N	170061601016
MOHAMED THAWFIQ S	170061601015
SHAKIL AKTHAR A	170061601023

In partial fulfillment of the requirement for the award of **Bachelor Degree in "Electronic and instrumentation Engineering"** from **B S Abdur Rahman Crescent Institute of Science and Technology** the internship training during the period from 18/12/2018 to 31/12/2018 at **Thermal Power Station-I Expansion, NLCI LTD., NEYVELI.**

Dy. Chief Engineer. (I&C)
TPS-I Expansion.
NLC Ltd., Neyveli-7

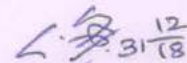
 31/12

SOWMYA G
DCE/C&I/TPS-I EXPANSION,
NLCI Limited, Neyveli.

Permitted to submit the Internship training report to College/University Authorities

 31/12

CHIEF MANAGER/L&D
Learning and Development
centre,
NLCI Limited,

Place : NEYVELI
Date : 31-12-2018

A.KATHIRVEL
CHIEF MANAGER
Learning and Development Centre
NLCI India Limited, Neyveli.

GSTIN:33GKIPS3389N1Z8

AKSHAYA MOTORS

Authorized Derik Motors (Mahindra)
Kulasekharam Road, Unnamalaikadai.P.O.,
Kanniyakumari District, Pin: 629179

Prop.:S.Venceslas

Mob.No.:9095071672

Date 07-08-2019

TO WHOM IT MAY CONCERN

This is to certify that, Mr. M. MOHAMED IJAZ KHAN, S/o. Mohamed Younoos. M, a student of MBA in B.S Abdur Rahman Crescent Institute of Science and Technology, Vandalur, Chennai has successfully completed his **internship** in our company from 01-06-2019 to 25-07-2019. During this period with us found punctual, hard work and inquisitive.

We wish him every success in his life.

For Akshaya Motors

Signature of
Proprietor

For AKSHAYA MOTORS

S. Venceslas
Proprietor



WoodStar Lines

TO WHOM IT MAY CONCERN

This is to certify that **MR.AHAMED ABDUL CADER N.M**, (RRN: 180292601005) a student of MBA (Major in logistics and supply chain), BSA CRESCENT INSTITUTE OF SCIENCE AND TECHNOLOGY, Chennai has joined our company as an intern for the period of Two months (From 11/06/2019 to 31/07/2019) internship programme at **WOODSTAR LINES Pvt Ltd.**

We wish him every success in life.



Authorized Signature

KAL RADIO LIMITED

Murugan Maran Towers, 73, MRC Nagar Main Road, MRC Nagar, Chennai - 600 028. INDIA
Tel: +91 - 44-4467 6767, Fax: +91 - 44-40675151 CIN: U92131TN2005PLC057755
Email: info@redfm.in Website: www.redfm.in

2nd August 2019

Sub: Internship Letter

Dear Anusha,

This is to certify that you have undergone an internship at Kal Radio Ltd - Chennai, from 4th June 2019 to 2nd August 2019. During the period, the conduct was good.

We wish all the success in your career and future endeavors.

For KAL Radio Limited

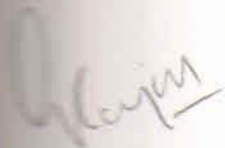

Rangarajan.G

MEM - HR & ADMIN

J.F

Mineral Water Industries



Packaged Drinking Water

Off.No : 04564 292303

Cell : 8124107777

IS : 14543



CM/L. 4751671

177, Kongampatti Road, Ilayangudi - 630702, Sivagangai District.

DATE: 08-08-2019.

TO WHOM SO EVER IT MAY CONCERN

This is to certify that **J.MOHAMED FAZEETH** has completed the Internship program at **J.F.MINERAL WATER INDUSTRIES** in the field of Finance and Operations Management, from **01.06.2019** to **31.07.2019**. His performance during the internship is good.

**J.F.MINERAL WATER INDUSTRIES
NO.177, KONGAMPATTI ROAD
IDAYAVALASAI PANCHAYAT
ILAYANGUDI - 630 702
SIVAGANGAI DIST**



alfanar Engineering Services India Pvt. Ltd.

"KG GALAXY", 2nd Floor, F-36, 2nd Avenue,
Anna Nagar East, Chennai – 600 102
INDIA

Tel: +91 44 6606 9598

Fax: +91 44 6606 9599

Email: corp@alfanar.com

www.alfanar.com / www.alfanarindia.com

31 July 2019

TO WHOMSOEVER IT MAY CONCERN

This is to certify that **Mr. MD WAQUIF RAZA (Reg.No-180292601058)** a student of **MBA (Master of Business Administration)** of **B.S. Abdur Rahman Crescent Institute of Science & Technology** has successfully completed a summer internship in the field of **Finance and HR Management** from **01st June 2019 to 31st July 2019.**

During the period of his internship programme with us he was found punctual, hardworking and inquisitive.

We wish him every success in his life and career.

For ALFANAR ENGINEERING SERVICES INDIA PVT. LTD.

(D. AMALRAJ)
ADMINISTRATION MANAGER





Port

Par - Excellence

चेन्नै पोर्ट ट्रस्ट

प्रशासनिक कार्यालय

ADMINISTRATIVE OFFICE

राजाजी सालै, चेन्नै- 600 001.

Rajaji Salai, Chennai-600 001.

Website : www.chennaiport.gov.in

CHENNAI PORT TRUST

सामान्य प्रशासन विभाग, चेन्नै - 600 001

CENTRE FOR HUMAN RESOURCES DEVELOPMENT

GENERAL ADMINISTRATION DEPARTMENT, CHENNAI - 600 001.

सं. वि.के/ INT Aug 36 /2019/जी ए

दिनांक: 31/07/2019

इंटरनशिप प्रमाणपत्र / INTERNSHIP CERTIFICATE

यह प्रमाणित किया जाता है कि श्री/सुश्री S/Selvi R.KIRUTHIKA, 180292601048, MBA, B.S.ABDUR RAHMAN CRESCENT INSTITUTE OF SCIENCE AND TECHNOLOGY, CHENNAI - 48 ने दिनांक 01.07.2019 से 31.07.2019 तक इंटरनशिप प्रशिक्षण प्राप्त किया है। इस अवधि के दौरान उनका/उनकी आचरण व चरित्र Excellent रहा।

It is certificated that S/Selvi R.KIRUTHIKA, 180292601048, MBA, B.S.ABDUR RAHMAN CRESCENT INSTITUTE OF SCIENCE AND TECHNOLOGY, CHENNAI - 48 ने 31.07.2019 has done "Internship Training" from 01.07.2019 to 31.07.2019 during this period his/her conduct and character was Excellent.



Secretary
Chennai Port Trust



**SEA XPERT SHIPPING AND
PROJECTS PVT. LTD**

Date: 31.07.2019

CERTIFICATE FOR INTERNSHIP

This is certify that / Mr. MOHAMED HASAN FAYAZ KS

Student of M.B.A (Management Studies) Reg No: 180292601064 from **B.S. Abdur Rahman CRESCENT INSTITUTE OF SCIENCE AND TECHNOLOGY**, Vandalur has successfully completed his 60 Days From 1st June to 31st July - 2019, internship program at SeaXpert Shipping and Projects Pvt Ltd, during the period of internship he worked in "Import and Export Management" of SeaXpert Shipping and Projects Pvt Ltd. He was found Punctual, Ambitious and hard working.

During the course of Training, He was good and shown keen interest in learning.

We wish him every success in life.

For SeaXpert Shipping & Projects Pvt Ltd



Authorized Signatory

Place: Chennai

Date: 31.07.2019

No.164, 5th street, F Block,
2nd Floor, Anna Nagar East,
Chennai - 600 102.

Tel : +91-44 - 45054411
+91-44 - 42333527

E-mail : trade@seaxpert.net



yes yem enterprises Pvt. Ltd.

Date : 31/07/2019

TO WHOM IT MAY CONCERN

This is to certify that Mr. Mohamed Eliyas .H. S/O MR. J. HAJI MOHAMED, a student of MA (Major Shipping & Logistics), B.S. Abdur Rahman Crescent Institute of Science and Technology has successfully completed one month from the date (01/06/2019 – 31/07/2019) internship programme At YES YEM ENTERPRISES PVT.LTD, Chennai. During the period of her internship programme with us he was found punctual, hardworking and inquisitive.

For YES YEM ENTERPRISES PVT. LTD.

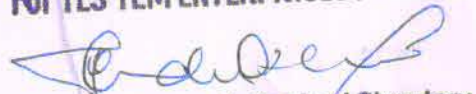

Authorized Signatory

SHIPPING, CLEARING & FORWARDING AGENTS

Head Office : New # 38, Old # 94, Moore Street, Chennai - 600 001. Phone : 25212722, 25243415

Fax : +91-44-25225494 E-mail : imports@yesyem.com



**SEA XPERT SHIPPING AND
PROJECTS PVT. LTD**

Date: 31.07.2019

CERTIFICATE FOR INTERNSHIP

This is certify that / Mr. MAHASUM RIZWAN. A

Student of M.B.A (Management Studies) Reg No: 180292601053 from B.S. Abdur Rahman CRESCENT INSTITUTE OF SCIENCE AND TECHNOLOGY, Vandalur has successfully completed his 60 Days From 1st June to 31st July - 2019, internship program at SeaXpert Shipping and Projects Pvt Ltd, during the period of internship he worked in "Import and Export Management" of SeaXpert Shipping and Projects Pvt Ltd. He was found Punctual, Ambitious and hard working.

During the course of Training, He was good and shown keen interest in learning.

We wish him every success in life.

For SeaXpert Shipping & Projects Pvt Ltd

Authorized Signatory



Place: Chennai

Date: 31.07.2019

No.164, 5th street, F Block,
2nd Floor, Anna Nagar East,
Chennai – 600 102.

Tel : +91- 44 - 45054411
+91- 44 - 42333527

E-mail : trade@seaxpert.net



BONAFIDE CERTIFICATE

Certified that this internship report **HUMAN RESOURCE MANAGEMENT** is the bonafide work of **MALARMANIR (180292601055)** who carried out the internship work under my supervision. Certified further, that to the best of my knowledge the work reported herein does not form part of any other project report or dissertation on the bases of which a degree or award was conferred on an earlier occasion on this or any other candidate.



28/08/19

Dr. DASHOKK

SUPERVISOR

Assistant Professor

Department of Management Studies

B.S Abdur Rahman

Crescent Institute of Science & Technology

GST Road , Vandalur, Chennai – 600 048



JEEVA GORKY.M

HUMAN RESOURCE

HR Officer

MORE RETAIL LIMITED

NO.17/30 2nd Cross Street

Trustpuram, Kodambakkam

Chennai – 600 024



28/8/19

Head of the Department

Department of Management Studies

B.S Abdur Rahman Crescent Institute of Science & Technology

GST Road , Vandalur, Chennai – 600 048

MORE RETAIL LIMITED

(Formerly known as Aditya Birla Retail Limited)

Head Office, B6/92, 5th & 6th Floor, Near Mittal Industrial Estate, Andheri Kurla Road, Andheri (East), Mumbai 400059, India.

T: +91 8652905555 | E: contactus@morestore.com | W: www.morestore.com

Corporate ID No : U65990MH1988PLC048117



CREATING WEALTH
FOR WELLBEING

NLC INDIA LIMITED

"NAVRATNA"-A Government of India Enterprise

Neyveli, Tamilnadu.

CERTIFICATE

This is to certify that the internship training report entitled "MATERIAL AND LOGISTICS MANAGEMENT" During the year of 2019 in "B.S.ABDUR RAHMAN CRESCENT INSTITUTE OF SCIENCE AND TECHNOLOGY -CHENNAI".

R.S.SRI.SABHARATHINAM

180292601105

This is to certify that this project report on "A STUDY ON MATERIAL AND LOGISTICS MANAGEMENT AT NLCIL" in Material Management complex, NLC India NEYVELI is the bonafide record of work done by R.S.SRI SABHARATHINAM (Reg.No.180292601105). It is a record of summer project done by him during the period from 13.06.19 to 26.07.19 at Material Management Complex, Neyveli. This summer Internship work report has not been submitted for the award of any degree in this University or any other University.

Kalaiselvi
26/7/19
EXTERNAL GUIDE
N.K.A. Complex,
Smt. N. Kalaiselvi,
DGM, MM COMPLEX,
NLCIC, NEYVELI

Permitted to submit this Internship work Report to University Authorities

[Signature]
26/7

CHIEF MANAGER
LEARNING AND DEVELOPMENT CENTRE
NLC INDIA LIMITED, NEYVELI,

A.KATHIRVEL
CHIEF MANAGER
Learning and Development Centre
NLC India Limited, Neyveli.

Date: 26/07/2019

Place: Neyveli

31st July 2019

TO WHOMSOEVER IT MAY CONCERN

This is to certify that **Mr. SANTHOSH. G**, II Year MBA student of “**B.S. Abdur Rahaman Crescent Institute of Science & Technology**”, Chennai, had successfully completed his Internship Training in our Sales Department from 01st June 2019 to 31st July 2019.

His attendance was found to be **92% (Ninety Two Percentages)**.

During this tenure his character and conduct was found to be good.

We wish him all the success.

B. RADHISH KUMAR
GENERAL MANAGER
HR & ADMIN.





BGR ENERGY SYSTEMS LIMITED
443 ANNA SALAI, TEYNAMPET, CHENNAI 600018 INDIA
TEL: +91 44 24301000 E-mail: response@bgrenergy.com
Web site: www.bgrcorp.com

BGR/HR-TRG/Project – 223
31st July 2019

INTERNSHIP TRAINING CERTIFICATE

Name : Ms J Kiruthika (Reg No:180292601047)
Period of Training : From 01.06.2019 to 31.07.2019
College : B.S. Abdur Rahman Crescent Institute of Science & Technology, Chennai
Branch of study : MBA - Final Year
Area of training : Human Resources Department
BGR Energy Systems Ltd.
Conduct : Good

We wish her all success in her future Endeavors.

Thanking You,

Yours faithfully,

For BGR Energy Systems Limited



M S Swaminathan

Assistant Vice President – Human Resources

REGISTERED OFFICE:

INDUSTRIAL ESTATE, RAMAPURAM POST, SULURPET TALUK, NELLORE DISTRICT, ANDHRA PRADESH 524401 INDIA
TEL: 91 44 27900181, 27948549 FAX: 91 44 27948249
Corporate Identity Number: L40106AP1985PLC005318

Shalom Garments Pvt. Ltd.,

Premium Garment Manufacturers & Exporters

TO WHOMOVER IT MAY CONCERN

This is to certify that **Mr. Mohamed Yashar Arafath M** (Reg No: 180292601070), First Year MBA student of “ Crescent Institute Science & Technology, Chennai- 600 048” has completed **Summer Internship In SHALOM GARMENTS PVT.LTD., VALLIOOR**” From 01.06.2019 to 31.07.2019 During the project period it has been observed that the candidate has shown interest in the subject and put extra efforts to learn the various aspects pertaining to the Study.

During his study period his character and conduct have been good.

For Shalom Garments Pvt. Ltd.



Authorized Signatory

Vallioor,

31.07.2019



216/A, Main Road, Vallioor, Tirunelveli District, Tamilnadu, India.
Ph.No:04637 222153, Fax 04637 222152 ,Email:admin@shelton.co.in



ECLATT CREATIONS

No.8/3556, Anna Nagar West,
P.N. Road, Pooluvapatti (Po),
TIRUPUR - 641 602. TN - INDIA.
GSTIN : 33AAGFE3492C1ZR

Date :

TO WHOMSOEVER IT MAY CONCERN

Certified that this **INTERNSHIP** report at **ECLATT CREATIONS** is the bonafide work done by **SANTHOSH. S** (RRN : 180292601099) who carried out the internship work under my supervision. Internship in our company for a period of 2 months from 01.06.2019 to 31.07.2019. Certified further that to the best of my knowledge the work reported herein does not form part of any other internship report or dissertation on the basis of which a degree or award was conferred on an earlier occasion on this or any other candidate.

For ECLATT CREATIONS

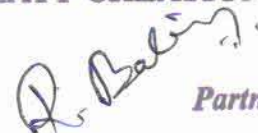
Partner

AUTHORISED SIGNATURE

A. S. SHIPPING AGENCIES PVT. LTD.

CONTAINER FREIGHT STATION

Numbal, Chennai - 600 077.

Tel. : 044-26494188 / 5166 / 3336. Fax : 044-26490161 / 0163

E-mail : cfs@shippingline.com

To

The Head of the Department

Department of Management Studies

Crescent Institute of Sciences and Technology,

Vandalur, Chennai 600 048

Sr,

Sub: Completion of Project work – Reg..

With reference to the above we wish to inform that Mr.SANTHOSH RAJ.B (RRN:180292601097) have completed his project work in logistics of Import and Export in our organization from 29.05.19 to 30.07.2019. During his internship, we found at his dedication at most satisfaction and we wishing him all the best in his career and future.

Thanking you,

Yours faithfully,

For A.s.Shipping Agencies Pvt.Ltd

Manager



#1405, 5th Street, 12th Main Road, 'H' Block,
Anna Nagar, Chennai - 600 040
Telefax : 91-44-4217 1326 Mobile : 98843 21447
Email : muthukumaran@entrep.in
Web : www.entrep.in

Date: 05th Aug 2019

Place: Chennai

TO WHOMSOEVER IT MAY CONCERN

This is to inform you that **Mr. Hari Krishnan.V** was working with **M/S VV Enterprises** while **M/S Entrep Business Consulting** as part of his summer internship in the area of **Recruitments** from the period **03rd June 2019 – 31st July 2019**. During the period, he was designated as **Recruitments Lead**, thereby catering to the manpower requirements of our **IT & IES** clients.

During the above mentioned period, he was found to be highly inquisitive, highly interactive with the team members and partners of the firm thereby providing valuable insights. He was appreciated by the clients for his excellent time management skills. His character and work was found to be highly satisfactory during the period.

He was paid a monthly maintenance allowance of **INR 30,000.00**. We wish him good luck in all his future endeavors.

Warm Regards,



VJAY.B

entrep

Business Consulting

Recruiting | Consulting | Advisory | Technology

SEAGULL MARINE SERVICES

S.R. Towers, 3rd Floor,
14, 4th Lane, North Beach Road,
Chennai - 600 001, India.

TEL. : +91-44-42163299 / 25243299 / 25249873

FAX : +91-44-25264363 / 42163301 V.H.F. : 16

E-mail : seagull-india@airtelmail.in

31/07/2019

TO WHOM SO IT MAY CONCERN

MR. FUSUF RAHIMUDEEN.B., REGISTRATION NUMBER : 180292601120

STUDENT OF B.S. ABDUR REHMAN CRESENT INSTITUTE OF SCIENCE &

TECHNOLOGY, UNDERGONE INTERNSHIP TRAINING ON SHIPPING & LOGISTICS IN

OUR ORGANISATION, SINCE 1ST JUNE TO 31ST JULY 2019 HE HAS

SUCCESSFULLY COMPLETED HIS INTERNSHIP TRAINING

WE WISH HIM IN ALL SUCCESS, DURING HIS PERIOD ATTENDING AND CONDUCT

WERE EXCELLENT

THANKING YOU

FOR SEAGULL MARINE SERVICES





NLC INDIA LIMITED

"NAVRATNA"-A Government of India Enterprise
Neyveli, Tamilnadu.

CERTIFICATE

This Is to Certify That the Internship Training report Entitled “**WORK FLOW AND PRODUCTION MANAGEMENT**” During the Year of 2019 in “**B.S.ABDUR RAHMAN CRESCENT INSTITUTE OF SCIENCE AND TECHNOLOGY –CHENNAI**”.

VIGINESH R

180292601118

In partial fulfilment of the requirement for the award of the Degree of MASTER OF BUISNESS ADMINISTRATION From B.S.ABDUR RAHMAN CRESCENT INSTITUTE OF SCIENCE AND TECHNOLOGY During The Year Of 2019. This is bonafide work of the candidate done During the Period of 2 Months from (01-06-2019 to 31-07-2019) At Thermal Power Station-I Expansion, NLC INDIA LIMITED, NEYVELI as an Internship report.

R Raja
30/7/2019
R RAJA

(External guide)
**CHIEF MANAGER
PLANNING AND SAFETY
TPS-1 EXPANSION**

Permitted to submit this Internship work Report to University Authorities

A. Kathirvel
1/8

**DATE : 31.07-2019
PLACE: neyveli**

**CHIEF MANAGER
LEARNING AND DEVELOPMENT CENTER
NLC INDIA LIMITED**

**A.KATHIRVEL
CHIEF MANAGER
Learning and Development Centre
NLC India Limited, Neyveli.**



MADRAS ENGINEERING INDUSTRIES PRIVATE LIMITED

Plot No. AA7, 6th Avenue, Auto Ancillary SEZ,
Mahindra World City, Chennai - 603 004,
Kancheepuram District, Tamilnadu, INDIA

☎ : +91 44 4742 3040
✉ : mei@mei.co.in
🌐 : www.mei.co.in

02/08/2019

Head of the Department,
Dept. of Management Studies,
R. S. Abdur Rahman Crescent Institute of Science & Technology,
(Deemed to be University),
Vandalur,

Sub: Summer Internship – Granted – Reg.
Ref: Your request letter No.MBA/PROJ/2018-2020, dated 26/04/2019

This is to certify that Mr. Vignesh P (Reg.No.180292601117) MBA student of Department of Management Studies, R. S. Abdur Rahman Crescent Institute of Science & Technology, deemed to be University, Vandalur, Chennai, has successfully completed his Summer - Internship in our Company for a period of Two Months between 01/06/2019 and 31/07/2019, and this is, in partial fulfillment of the requirements for the award of MBA degree.

During the above period he was found to be sincere. We wish him all success in his future endeavors.

With Regards

Yours truly,

Dr. M. J. Arputharaj
GM – Human Resources



B.S. Abdur Rahman
Crescent

Institute of Science & Technology
Deemed to be University u/s 3 of the UGC Act, 1956
GST Road, Vandalur, Chennai 600 048

BONAFIDE CERTIFICATE

Certified that this project report **WORK FLOW AND PRODUCTION MANAGEMENT** is the bonafide work of S. VENKATESH(RRN:180292601116) who carried out the project work under my supervision. Certified further, that to the best of my knowledge the work reported herein does not form part of any other project report or dissertation on the basis of which a degree or award was conferred on an earlier occasion on this or any other candidate.

SIGNATURE

CHANDRIKA SRINIVAS

SUPERVISOR

Assistant Professor (Sr. Gr)

Department of Management Studies

SA, Crescent Institute of Science & Technology

SIGNATURE

M. MURUGAN

MANAGER-HR & ADMIN



LOTTE INDIA CORPRATION LMT

Morai street, cuddalore Road

Cuddalore Dist

Nellikuppam-607105

SIGNATURE

Head of the Department

Department of Management Studies

ACKNOWLEDGEMENT

INTERNSHIP CERTIFICATE

"This is to certify that Mr. V.VIGNESH, Reg No:180292601122, MBA from BS ABDUR RAHMAN CRESCENT INSTITUTE SCIENCE & TECHNOLOGY UNIVERSITY has successfully completed summer internship program at SHS ADVISORY GROUP. The duration of this project was from 03-JUNE-2019 to 31-JUL-2019.

He has closely worked as a part of FINANCE & ACCOUNTS DEPARTMENT.

During the period of his internship program with us he was found punctual, hardworking and inquisitive.

I hereby certify his work was excellent to the best of my knowledge.

For, SHS ADVISORY GROUP.

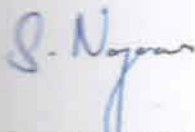

NARAYANAN SWAMINATHAN

ACKNOWLEDGEMENT

INTERNSHIP CERTIFICATE

"This is to certify that Mr. V.VIGNESH, Reg No:180292601122, MBA from BS ABDUR RAHMAN CRESCENT INSTITUTE SCIENCE & TECHNOLOGY UNIVERSITY has successfully completed summer internship program at SHS ADVISORY GROUP. The duration of this project was from 03-JUNE-2019 to 31-JUL-2019.

He has closely worked as a part of FINANCE & ACCOUNTS DEPARTMENT.

During the period of his internship program with us he was found punctual, hardworking and inquisitive.

I hereby certify his work was excellent to the best of my knowledge.

For, SHS ADVISORY GROUP.

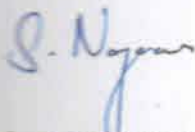

NARAYANAN SWAMINATHAN

16.07.2019

TO WHOMSOEVER IT MAY CONCERN

This is to certify that Mr.Mohamed Asif (180292601061) student of MBA in CRESCENT INSTITUTE OF SCIENCE AND TECHNOLOGY has successfully completed his "INTERNSHIP" in our Organisation between 11th June 2019 and 16th July 2019.

We wish him all the best in his future endeavor.

For SUPER AUTO FORCE PRIVATE LTD

ALAMELU PRIYA.R
CORP - Human Resources



IATF 16949:2016
Certified by IRQS



ISO 14001:2015
Certified by IRQS



MGMT. SYS.
RvA C 071



OHSAS 18001:2007
Certified by IRQS



MGMT. SYS.
RvA C 071



SABIN LOGISTICS PVT LTD

Custom House Agent

No:41a , Vembullammankoil Street, Palavanthangal , Chennai -600 114. INDIA

Ph: 91-44-2224 8773

Email : sabinairexportoperation@sabinlogistics.com



Date:31 July 2019

CERTIFICATE OF COMPLETION OF INTERNSHIP PROGRAMME

This is to certify that Mr. MOHAMMED ALI.I pursuing MBA at B.S.ABDUR RAHMAN CRESCENT INSTITUTE OF SCIENCE & TECHNOLOGY has completed the internship program at SABIN LOGISTICS PVT LTD,Chennai. For a period of 60 days, starting from 01 june 2019 to 31 july 2019. He has done his work report with Import & Export departments. During the period of his internship program with us he was found punctual and hardworking.

We wish him every success in his life.

For SABIN LOGISTICS PVT. LTD.

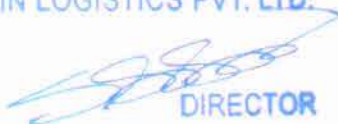

DIRECTOR

(S.LOGANATHAN)

Managing Director



SAR WORLDWIDE LOGISTICS PVT. LTD.,

International Couriers & Cargo Forwarders

July 31st 2019

TO WHOMSOEVER IT MAY CONCERN

This is to certify that **Mr. S.MILTON AROCKIA RAJ** (Regn. No. : **180292601059**) from **B.S. ABDUR RAHMAN CRESCENT UNIVERSITY, Department of Management** has successfully completed his Internship in our Concern from June 03,2019 to July 31,2019. We wish him all the very best in his future assignments.

Thanking You,

Yours truly,
For **SAR WORLDWIDE LOGISTICS PVT. LTD.,**



Authorised Signatory.

23/08/2019

Internship - Completion Certificate

This is to certify that JS Johnet Roshini, has successfully completed her Internship with us, during the period June 3rd to July 31st.

Her internship includes various activities in Market Research pertaining to our company.

We wish her every success in life!

May God bless her in all her future endeavours.

Sincerely,



Samuel Harris,

Founder - TIEKE.

NCR Corporation India Pvt. Ltd.

14/1A, Mahindra World City,
Veerapuram Village,
Chengalpattu Taluk,
Tamil Nadu - 603004, India.
Tel : +91-44 6618 9999
Fax : +91 -44 6618 9797



29th July 2019

TO WHOMSOEVER IT MAY CONCERN

This is to certify that **Mr. Infa Joel A (Reg. No: 180292601040)**, student of **B.S. Abdur Rahman Crescent Institute of Science and Technology, Vandalur** has successfully undergone his Summer Internship here at **NCR Corporation India Private Limited**, Chennai from 24.06-2019 to 29.07.2019

His Punctuality, Behavior, Conduct and Progress during the Internship were good.

For NCR Corporation India Private Limited

V. Venkatesh V
Venkatesh V
Manager - Human Resources





Date: August,08,2019

To whom so ever it may concern

This is inform that Mr,IJAZ AHMED.A has completed the Industrial internship program in **SUPPLY CHAIN MANAGEMENT** at our organisation Enco Shoes, Chennai from 01.June.2019 till 31.July.2019.

In this short term, he had worked in all our departments and gained the knowledge related to supply chain management.

He was punctual, attentive and participated in the company work and involved in practical activities.

We wish him good luck for future career.

For enco shoes

General Manager
Syed Nizamuddin.S





Date: August,08,2019

To whom so ever it may concern

This is inform that **Mr,IJAZ AHMED.A** has completed the Industrial internship program in **SUPPLY CHAIN MANAGEMENT** at our organisation Enco Shoes, Chennai from 01.June.2019 till 31.July.2019.

In this short term, he had worked in all our departments and gained the knowledge related to supply chain management.

He was punctual, attentive and participated in the company work and involved in practical activities.

We wish him good luck for future career.

For enco shoes

General Manager
Syed Nizamuddin.S





K C M S & ASSOCIATES

Chartered Accountants

No.31, Bharathi Nagar,
1st Street, 3rd Lane,
T. Nagar, Chennai - 600 017.
Ph : 044 - 4212 1674
E-mail : jvenkat@kcms.co.in
onjkumar@kcms.co.in

DATE: 03/08/2019

TO WHOMSOEVER IT MAY CONCERN

INTERNSHIP TRAINING CERTIFICATE

This is to certify that **Ms.R.HARINI (Reg No: 180292601036)** student of first year MBA of B.S.Abdur Rahman Crescent Institute of Science & Technology, Chennai has successfully completed her Internship Training at our office, T.Nagar for the period of 2 months from 03/06/2019 to 03/08/2019 .

She had extensive training in the day to day affairs of our office and covered areas with respect to MS WORD & MS EXCEL, Tally –ERP Software, Bank Reconciliation Statements, GST, TDS, and Income Tax Computation -Filing of Individual Returns. During the period of internship her conduct and character had been OUTSTANDING. She has maintained good discipline, punctuality and moved with all our office colleagues respectfully.

We wish her all the best in all her future endeavours.

For **KCMS & ASSOCIATES**
CHARTERED ACCOUNTANTS

CHARTERED ACCOUNTANTS

Firm Regn. No. 006770S

J. VENKATARAMANAN
(PARTNER)

17.08.2019



To whom so ever it may concern

This is to certify that **Mr. GODSON JUBILEE .F R** , has completed the Industrial Internship program at **SEAWAVES SHIPPING SERVICES** for a period from 06.06.2019 to 17.08.2019 has done internship on **A Study on Challenges faced by the Freight Forwarders in India**. His performance during the internship is good.

He is attentive to participate in the company work and involved in practical operations of our shipment.

We wish you Good Luck for further Career.

For SEAWAVES SHIPPING SERVICES



V. Ganesh Kumar
(Ocean Export Manager)

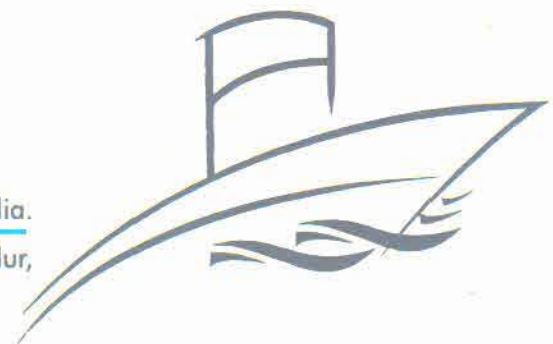



20.08.2019

To whom so ever it may concern

This is to certify that **Mr. J. BHARATH KUMAR** , has completed the Industrial Internship program at **SEAWAVES SHIPPING SERVICES** for a period from 05.06.2019 to 04.07.2019 has done internship on **A Study on Challenges faced by the Freight Forwarders in India**. His performance during the internship is good.

He is attentive to participate in the company work and involved in practical operations of our shipment.

We wish you Good Luck for further Career.

For SEAWAVES SHIPPING SERVICES



W. Ganesh Kumar
(Ocean Export Manager)





Flow Control Division

Flowserve India Controls Pvt. Ltd.

B-8, CMDA Industrial Area, Maraimalai Nagar 603 209,

Kanchipuram Dist. Tamil Nadu. INDIA

E mail : info.mmn@flowserve.com

Phone : + 91 44 27452323, Fax : + 91 44 27452327

CIN No : U85110KA1996PTC021388

Manufacturer of AUDCO Plug and Slimseal Valves

1st Aug 2019

TO WHOMSOEVER IT MAY CONCERN

This is to Certify that Mr. N Balaji (Reg no.180292601018) studying First year Master of Business Administration in B.S. Abdur Rahman Crescent Institute of Science and Technology, Chennai had undergone Inplant Training at Flowserve India Controls Pvt. Ltd, Maraimalainagar from 3rd June 2019 to 31st July 2019.

He had undergone his Internship under our guidance and was sincere and evinced keen interest in learning.

for FLOWSERVE INDIA CONTROLS PVT LTD.,

J. Karthickeyan
Regional HR Manager
Maraimalainagar



NLC INDIA LIMITED

"NAVRATNA"-A Government of India Enterprise

Neyveli, Tamilnadu.

CERTIFICATE

This is to certify that the internship training report entitled "**WORK FLOW AND PRODUCTION MANAGEMENT**" During the year of 2019 in "**B.S.ABDUR RAHMAN CRESCENT INSTITUTE OF SCIENCE AND TECHNOLOGY – CHENNAI**".

JAGADISH U

180292601043

In partial fulfilment of the requirement for the award of Degree of MASTER OF BUSINESS ADMINISTRATION in the department of OPERATIONS MANAGEMENT From B.S.ABDUR RAHMAN CRESCENT INSTITUTE OF SCIENCE AND TECHNOLOGY during the year of 2019. This is Bonafide work of the candidate done during the period of 8 weeks from (01-06-2019 to 26-07-2019) at Thermal Power Station-I Expansion, NLC INDIA LIMITED, NEYVELI as an Internship report.

25/7/2019
R RAJA
(External guide)
CHIEF MANAGER
PLANNING & SAFETY
TPS-I EXPANSION
NLC India Limited
507807

Permitted to submit this Internship work Report to University Authorities

Date: 26/07/2019

Place: Neyveli

26/7
CHIEF MANAGER
LEARNING AND DEVELOPMENT CENTRE
NLC INDIA LIMITED, NEYVELI,

A.KATHIRVEL
CHIEF MANAGER
Learning and Development Centre
NLC India Limited, Neyveli.

Shalom Garments Pvt. Ltd.,

Premium Garment Manufacturers & Exporters

TO WHOMOVER IT MAY CONCERN

This is to certify that **Mr. Ibrahim Badhusha Harish S** (Reg No: 180292601038), First Year MBA student of "Crescent Institute Science & Technology, Chennai- 600 048" has completed **Summer Internship In SHALOM GARMENTS PVT.LTD., VALLIOOR** From 01.06.2019 to 31.07.2019 During the project period it has been observed that the candidate has shown interest in the subject and put extra efforts to learn the various aspects pertaining to the Study.

During his study period his character and conduct have been good.

Vallioor,

31.07.2019

For Shalom Garments Pvt. Ltd.

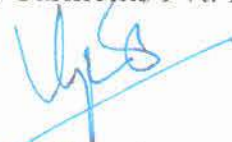

Authorized Signatory



Seawaves
Shipping Services

+91 44 4318 1244
+91 44 4318 1244
www.seawaves.co.in

20.08.2019

To whom so ever it may concern

This is to certify that **Mr. A. FAYSAL AHMED** , has completed the Industrial Internship program at **SEAWAVES SHIPPING SERVICES** for a period from 01.06.2019 to 31.07.2019 has done internship on **A Study on Challenges faced by the Freight Forwarders in India**. His performance during the internship is good.

He is attentive to participate in the company work and involved in practical operations of our shipment.

We wish you Good Luck for further Career.

For SEAWAVES SHIPPING SERVICES

V. Ganesh Kumar
(Ocean Export Manager)

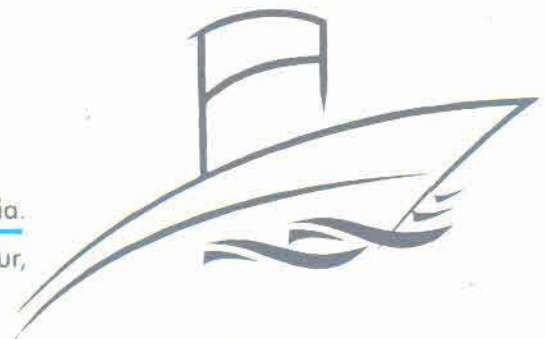

July 31, 2019

CERTIFICATE OF COMPLETION OF INTERNSHIP PROGRAM

This is to Certify that Edwin Amal.J (RRN No: 180292601030), a student of Crescent Institute of Science & Technology CHENNAI carrying out a Degree in MBA has successfully completed the Internship program under our supervision in for a period of 60 days Dated from 01st June to 31st July 2019 at LOTUS INTEGRATED LOGISTICS PRIVATE LIMITED.

During the Internship he was Self – motivated attitude to learn new things. His performance was Good and able to complete the work in time.

We wish him all the success for his future endeavours.

Yours Sincerely,

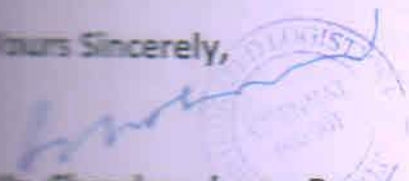
Mr. Chandrasekaran.R
Administration Officer



31/07/2019

ACADEMIC INTERNSHIP COMPLETION LETTER

We like to confirm the below student, who has completed first year MBA in B.S Abdur Rahman Crescent Institute of Science and Technology, Chennai has successfully completed the summer internship in our concern from 07/06/2019 to 31/07/2019.

STUDENT NAME	REG. NO
Mr. Syed Ismail. S	180292601112

During the tenure with us, conduct & behavior was observed to be good.

We wish success in all the future endeavors.

For Autokshi Engineers [P] Ltd,



Vairavanathan. A

Authorized Signatory

AUTOKSHI ENGINEERS PRIVATE LIMITED

75, Sengundram Road, Malrosapuram Village, Maraimalainagar, Chennai - 603209
Contact@autokshiengineers.com | Ph: 044- 43322527



Shri Ayngaran Business Chits Private Limited

Registered Office "Lion Cave", No. 51, Kotrampalayam Street,
Kanchipuram - 631 501, Kanchipuram District.

Date.....

To:

Head of the Department,
Crescent Institute of Science & Technology,
GST Road Vandalur,
Chennai-600048.

Dear Sir,

Sub: Reg Requisition to grant permission for Internship

Greeting from **SHRI AYNGARAN BUSINESS CHITS PRIVATE LIMITED!!!**

This is to confirm that your request for Mr. Suriyanarayana, E for Internship Trainee starting from 10th June 2019 to 03th Aug 2019 with us has been accepted.

This project is given to your student to pursue his academic interest, and hereby advised not to disclose publish or part with any information which he would have come to know in course of the project with us to anybody except your college. He will not be provided any monetary benefits during the project with us. He is also advised to strictly follow the instructions, rules, regulations and norms of the Company / Supervisor, failing which his project will be cancelled without notice or explanation whatsoever.

For Shri Ayngaran Business Chits Private Limited,

Director.

H.P.T. Item Code No. C-81804355

500 Pads 27-11-2018



ISPS Code Compliant
© 2011 - 2015 Certified



Port
Par - Excellence
चेन्नै पोर्ट ट्रस्ट

CHENNAI PORT TRUST

सामान्य प्रशासन विभाग, चेन्नै - 600 001

CENTRE FOR HUMAN RESOURCES DEVELOPMENT

GENERAL ADMINISTRATION DEPARTMENT, CHENNAI - 600 001.

Fax : +91-44-25361228

Phone: +91-44-25312000

: +91-44-25362201

प्रशासनिक कार्यालय

ADMINISTRATIVE OFFICE

राजाजी सालै, चेन्नै- 600 001.

Rajaji Salai, Chennai-600 001.

Website : www.chennaiport.gov.in

मं.सं.वि.कें/ INT 663 /2019/जी ए

दिनांक: 31/07/2019

इंटरनशिप प्रमाणपत्र / INTERNSHIP CERTIFICATE

यह प्रमाणित किया जाता है कि श्री/सुश्री S/Selvan M.SUDHARSHAN, 180292601107, MBA, B.S.ABDUR RAHMAN CRESCENT INSTITUTE OF SCIENCE AND TECHNOLOGY, CHENNAI - 48 ने दिनांक 01.06.2019 से 31.07.2019 तक इंटरनशिप प्रशिक्षण प्राप्त किया है। इस अवधि के दौरान उनका/उनकी आचरण व चरित्र Excellent रहा।

It is certificated that S/ Selvan M.SUDHARSHAN, 180292601107, MBA, B.S.ABDUR RAHMAN CRESCENT INSTITUTE OF SCIENCE AND TECHNOLOGY, CHENNAI - 48 ने दिनांक has done "Internship Training" from 01.06.2019 to 31.07.2019 during this period his/her conduct and character was Excellent.

Secretary
Chennai Port Trust



TOP July 2019
NH/HR/OBS/2019/0023

TO WHOMSOEVER IT MAY CONCERN

This is to certify that **Ms. Subaidha Begam Mohamed Khan** has performed and completed the Observer ship program under the Preceptorship of Ms. Roudaina Halabi, Business Development Officer, Business Development Department at the Nation Hospital Abu Dhabi, United Arab Emirates.

Nation Hospital is a 144 bedded tertiary care hospital in Abu Dhabi providing high quality patient care based on international protocols and evidence-based practices. Nation hospital has more than 15 active specialties and 7 Operating rooms, Cath lab, 15 level 3 critical care beds, endoscopy suit and full modality Radiology and Laboratory services.

Ms. Subaidha Begam commenced her observer ship on 2nd June 2019 and completed on 31st July 2019

We wish her success on all his higher education and future endeavors.

Yours Sincerely,



Mr. Mohamed Yasin Kamal Batcha
Human Resource Lead



Bringing Life to Health لصحة نابضة بالحياة

FUTURE RETAIL

Date: 31-07-2019

TO WHOMSOEVER IT MAY CONCERN

This is to Certify that **Ms. A MARLIN SUSILA (Roll No: 180292601057)** MBA Student from B.S.Abdur Rahman Crescent Institute of Science Technology has completed her summer internship in HR department in our Organization from **June-2019 to July-2019**. During this tenure she has undertaken various tasks in management and has successfully completed them to her best of her abilities. Her conduct has been excellent during this tenure

We wish her good luck for her future carriers

For Future Retail Limited

Naresh. P J
Senior Executive-HR

BIG BAZAAR
Div. of Future Retail Ltd.
Express Avenue, SITE
Anchof-I, Goco-I 4963
49/60L, White Road,
Royapettah, Chennai-600 014



SAR WORLDWIDE LOGISTICS PVT. LTD.,

International Couriers & Cargo Forwarders

July 31st 2019

TO WHOMSOEVER IT MAY CONCERN

This is to certify that Mr. **M.MOHAMED ASIF HUSAIN** (Regn. No. : 180292601060) from **B.S.ABDUR RAHMAN CRESCENT UNIVERSITY**, Department of Management has successfully completed his Internship in our concern from June 03,2019 to July 31,2019.We wish him all the very best in the future assignments.

Thanking you,

Yours Truly,

For **SAR WORLDWIDE LOGISTICS PVT. LTD.,**

Authorised Signatory.



SAR WORLDWIDE LOGISTICS PVT. LTD.,

International Couriers & Cargo Forwarders

July 31st 2019

TO WHOMSOEVER IT MAY CONCERN

This is to certify that Ms C.S.MAHESWARI (Regn. No.: 180292601054) from B.S. ABDUR RAHMAN CRESCENT UNIVERSITY, Department of Management has successfully completed her Internship in our Concern from June 03,2019 to July 31,2019.We wish her all the very best in his future assignments.

Thanking You,

Yours truly,

For SAR WORLDWIDE LOGISTICS PVT. LTD.,



Authorised Signatory.

Chennai Office : No 504, Ground Floor, M.K.N. Road, Alandur, Chennai - 600016. Tel : 044 - 2231 2990 / 6539 0949
Telefax : 044 - 2231 2980 Email : sarexpress@gmail.com Website : sarxpress.com

Bangalore Office : No. 5A/76, 2nd Floor, BDA Flat, Domlur 2nd Stage, Bangalore - 560 071. Tel: 080 2535 7484



**SEA XPERT SHIPPING AND
PROJECTS PVT. LTD**

Date: 31.07.2019

CERTIFICATE FOR INTERNSHIP

This is certify that / Mr. MOHAMED IRFAN. P.M.J

Student of M.B.A (Management Studies) Reg No: 180292601066 from B.S. Abdur Rahman CRESCENT INSTITUTE OF SCIENCE AND TECHNOLOGY, Vandalur has successfully completed his 60 Days From 1st June to 31st July - 2019, internship program at SeaXpert Shipping and Projects Pvt Ltd, during the period of internship he worked in "Import and Export Management" of SeaXpert Shipping and Projects Pvt Ltd. He was found Punctual, Ambitious and hard working.

During the course of Training, He was good and shown keen interest in learning.

We wish him every success in life.

For SeaXpert Shipping & Projects Pvt Ltd



Authorized Signatory

Place: Chennai

Date: 31.07.2019

No.164, 5th street, F Block,
2nd Floor, Anna Nagar East,
Chennai - 600 102.

Tel : +91- 44 - 45054411
+91- 44 - 42333527

E-mail : trade@seaxpert.net

K.K.R INDUSTRIES

Dealers in : Car body parts mfg , M.S Sheet Works

06th June 2019

CERTIFICATE

This is to certify that Mr.MOHAMED SAMEEM.A (Reg. No:180292601069) student of First year MBA of your college B.S.ABDUR RAHMAN CRESCENT INSTITUTE OF SCIENCE & TECHNOLOGY has successfully completed this Internship Training from the date 06/06/2019 To 25/07/2019 in our industry. During this Internship Training, we found that he is very sincere, hardworking and fully devoted to assignment.

Thanking you



YOUR'S FAITHFULLY,
K. K. R. INDUSTRIES
6/245 A, Seevalaperi Road, Anna Nagar
Palayamkottai - 627002.
For K.K.R Industry.

K.K.R INDUSTRIES

6/245-A, Seevalaperi Road, Anna Nagar

Palayamkottai - 627002 ,Tirunelveli,



TO WHOMSOEVER IT MAY CONCERN

This is to certify that, **Mr. LOKESH.A (ID.No: 180292601052)** S/o. Anbuthambi from BS Abdur Rahman Crescent Institute of science and Technology, Vandalur, Chennai has been successfully completed his Inplant training in our esteemed organisation for the period 01-06-2019 to 31-07-2019.

During the period his conduct was Good and Satisfactory.

We wish him all success in his future endeavours.

Thanking you.

For Reep Industries Private Limited

A handwritten signature in blue ink, appearing to read "A. Lokesh".

Authorised Signatory.

REEP INDUSTRIES PRIVATE LIMITED



SAR WORLDWIDE LOGISTICS PVT. LTD.,

International Couriers & Cargo Forwarders

July 31st 2019

TO WHOMSOEVER IT MAY CONCERN

This is to certify that **Mr. M.ASRAF AHAMED** (Regn. No. : **180292601014**) from **B.S. ABDUR RAHMAN CRESCENT UNIVERSITY, Department of Management** has successfully completed his Internship in our Concern from June 03,2019 to July 31,2019. We wish him all the very best in his future assignments.

Thanking You,

Yours truly,
For **SAR WORLDWIDE LOGISTICS PVT. LTD.,**



Authorised Signatory.

Chennai Office : No 504, Ground Floor, M.K.N. Road, Alandur, Chennai - 600016. Tel : 044 - 2231 2990 / 6539 0949
Telefax : 044 - 2231 2980 Email : sarexpress@gmail.com Website : sarxpress.com

Bangalore Office : No. 5A/76, 2nd Floor, BDA Flat, Domlur 2nd Stage, Bangalore - 560 071. Tel : 080 2535 7484.

16.08.2019

TO WHOMSOEVER IT MAY CONCERN

This is to certify that Mr. Abbas R, student of B.S. Abdur Rahman Institute of Science and Technology, Chennai pursuing M.B.A [Finance and Marketing] with RRN:1800292601001 has successfully completed two month internship program from 3rd June 2019 to 31st July 2019 for Rythm Business Enterprises an authorized channel for ICICI Bank Ltd.

During the internship period, we found Mr. Abbas R to be hardworking and committed.

We wish him great success for his career prospects and future endeavor.

For Rythm Business Enterprises

Authorized Signatory



DHL LOGISTICS PVT. LTD.

Company No: 434945, 434946, 435/2, 437/A
Office: Mannur Taluk, Sriperumbudur
Dist: Vellore
Pin/Post: - 602 105, India
Tel: 01-8244826306 / 307 / 308 / 310



INTERNSHIP TRAINING CERTIFICATE

Name : S. Valarmathi
Period of Training : From 01-06-2019 to 31-07-2019
College : BSA Crescent Institute of Science & Technology
Branch of study : MBA (Logistics and Supply Chain Management)
Area of Training : Customer Service in DHL LOGISTICS PVT LTD
Conduct : Good

This is to certify that Ms S.VALARMATHI studying MBA (Logistics and supply chain Management) in BSA Crescent Institute of Science & Technology, Chennai has successfully completed her internship in Customer Service in our company M/S DHL Logistics Private Limited (A unit in J MATADEE Free Trade Warehousing Zone, Mannur Village Sriperumbudur Taluk.

We wish all success in her future endeavours.

Thanking You,

Yours faithfully,
For DHL LOGISTICS PVT LTD.

C Sampath
Manager – Customer Service, Customs & Compliance
(Authorized signatory)



DHL GLOBAL FORWARDING

Regd. Office
DHL LOGISTICS PVT. LTD.
(Formerly known as DHL Lemur Logistics Pvt. Ltd.)
33/1A, Silver Oyster,
Central Express Road, Chakala,
Western East, Mumbai - 400 099, India.

www.dhl.com CIN : U63090MH1996PTC099340

Services are subject to the Company's Standard Trading Conditions Copies are available on request.



युनाइटेड इंडिया इन्श्यूरेन्स कं. लि.
UNITED INDIA INSURANCE CO. LTD.

CIN: U93090TN1938GO1000108

BRANCH OFFICE: 560X KANDAN COMPLEX, VALLIOOR-627117

Phone: 0452 222266 Website: www.uic.co.in

BO: VLR: PJ: 02: 2019

DATE: 01.08.2019

TO WHOMSOEVER IT MAY CONCERN

This is to certify that **Mr. ASAN BILAL S, MBA** student of Crescent Institute of Science and Technology, has completed the Project Study at Branch Office, Vallioor.

During the above project period from **11.06.2019 to 31.07.2019**, his Conduct and Character were Good.

We wish him all success in all his future endeavors.

SR BRANCH MANAGER



DAKSH
KNOWLEDGE VENTURE

31/07/2019

TO WHOM SO EVER IT MAY CONCERN

This is to certify that **Ms. Dishilya** of M.B.A Batch 2018-2020 of **B.S.Abdur Rahman Crescent Institute of Science & Technology (Chennai)** has successfully completed her Summer Internship during June 2019 to July 2019.

During this tenure of her work **Ms. Dishilya** remained involved in her work dedicated. We found her active in whatever task we have provided to her. She is a confident person. She has the motivation to take initiative tasks and we are gratified that she had been helpful in the advancement of our organization.

We wish her all the best in her future endeavor.

For Daksh Knowledge Venture Pvt Ltd.,

Authorised Signatory



Daksh Knowledge Venture Pvt. Ltd.

Reg Office: No.15 MIG, NH - 1, Adikalar Road, Maraimalai Nagar, Kanchipuram – 603 209.

W Office: No.38/169, Annai Complex, 1st Floor, Opp to Jain Temple, Ayyasamy Street, West Tambaram, Chennai – 600 045.

Br Office: No.2, Mahatma Gandhi Street, Chelliamman Nagar Extn, Ambattur, Chennai – 600 058.



Bridgestone India Automotive Products Pvt Ltd

Registered Office : No 136, Vaipur 'B' Block,

Erarayur Village, Mathur Post, Sriperumbudur Taluk,

Kanchipuram DT, Tamil Nadu - 602105, India.

CIN : U74999TN2008PTC069492

Ph : +91-44-2715 2500, Fax : +91-44-2717 3517

E-mail : bsia@bsia.co.in

www.bsia.co.in

Date: 05th July 2019.

SUB: INTERNSHIP COMPLETION LETTER

We are glad to inform you that **Mr. M. Manikandan, REG NO: 180292601056** from B.S. Abdur Rahman Crescent Institute of Science & Technology has successfully completed his internship at Bridgestone India Automotive Products Private Limited, Chennai from **11th June 2019** to **31st July 2019**.

During the internship, he underwent observation in various Practices involved in Human Resources Department.

His interest level in learning the subject is very much appreciated.

We wish him success for all his future endeavours.

For Bridgestone India Automotive Products Private Limited.,

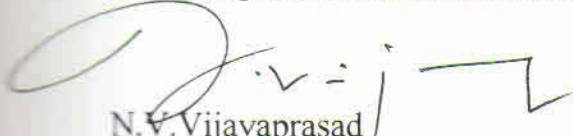
N.V. Vijayaprasad
Head HR.



Bridgestone India Automotive Products Pvt Ltd

Registered Office : No 136, Vaipur 'B' Block,

Eraiyur Village, Mathur Post, Sriperumbudur Taluk,

Kanchipuram DT, Tamil Nadu - 602105, India.

CIN : U74999TN2008PTC069492

Ph : +91-44-2715 2500, Fax : +91-44-2717 3517

E-mail : bsia@bsia.co.in

www.bsia.co.in

Date: 05th July 2019.

SUB: INTERNSHIP COMPLETION LETTER

We are glad to inform you that **Mr. M. Manikandan, REG NO: 180292601056** from B.S. Abdur Rahman Crescent Institute of Science & Technology has successfully completed his internship at Bridgestone India Automotive Products Private Limited, Chennai from **11th June 2019** to **31st July 2019**.

During the internship, he underwent observation in various Practices involved in Human Resources Department.

His interest level in learning the subject is very much appreciated.

We wish him success for all his future endeavours.

For Bridgestone India Automotive Products Private Limited.,

N.V. Vijayaprasad
Head HR.



30th July, 2019
Chennai

TO WHOMSOEVER IT MAY CONCERN

This is to certify that **Ms. Sneha G**, studying MBA at B.S. Abdur Rahman Crescent Institute of Science and Technology has undergone internship training in **Accounts Department** of our concern for a period starting, 6th June 2019 to 6th July 2019. The work performed by her was satisfactory. We wish her all success in her future endeavours.

for Sundaram BNP Paribas Home Finance Ltd.

Ganesh J
Head - HR

Sundaram BNP Paribas Home Finance Limited.

Sundaram Towers, 46, Whites Road, Chennai - 600 014.

Ph : +91 44 2851 5267, 2851 5269 Fax : +91 44 2858 2235

Registered Office : 21, Patullos Road, Chennai - 600,002.

PAN : AADCS4826J CIN : U65922TN1999PLC042759

Email : corporateaffairs@sundarambnpphome.in Web-Site : www.sundarambnpphome.in



भारत हेवी इलेक्ट्रिकल्स लिमिटेड

(भारत सरकार का उपक्रम)

Bharat Heavy Electricals Limited

(A Govt. of India Undertaking)

Power Sector - Southern Region,

Periyar EVR Building, 690, Anna Salai,

Nandanam, Chennai - 600 035.



ISO 9001 : 2015
Certified company

PSSR:HR:508
01.08.2019

TO WHOMSOEVER IT MAY CONCERN

This is to certify that **Ms. Logeshwari M**, (Reg. No. 180292601050) I-year MBA student of B.S. Abdur Rahman Crescent Institute of Science & Technology, has undergone summer internship at Finance & Accounts Department of PSSR, Headquarters, Chennai from 01.06.2019 to 31.07.2019.

She has been imparted training in various areas such as Establishment, PF & Pension.

She has diligently attended to the work allocated to her during this period and has completed her internship to our satisfaction.

We wish her a bright future.

(Ravindra Babu T)
Dy. Manager/HR

टी. रवीन्द्र बाबु
T. RAVINDRA BABU
उप प्रबंधक (मा.सं)
Dy. Manager (HR)

बी.एच.ई.एल. - पी.एस.एस.आर. / B.H.E.L. - P.S.S.R.
पेरियार ई वी आर बिल्डिंग / Periyar EVR Building
690, अन्ना साली, नन्दनम, चेन्नै - 600 035.
690, Anna Salai, Nandanam, Chennai - 600 035.



KSL/HRD/TRN/2019/ ISO 9001:2015/ OHSAS 18001:2007/ISO: 14001, UK CARES certification Surveillance audit for QMS 9001:2015 and BS 4449:2005 B500B

Sub: Completion of Summer Internship 11th June to 31st July 2019.

TO WHOMSOEVER IT MAY CONCERN

This is to Ms. Saranya D, Registration No: (180292601100), Second Year (II), Management Studies - MBA, B.S. Abdur Rahman, Crescent Institute of Science & Technology, has successfully completed Summer Internship with us as per the following details:

Duration of the Project: 11/06/2019 To 31/07/2019

Topic: A STUDY ON EMPLOYEES ENGAGEMENT IN KAMACHI INDUSTRIES LIMITED.

Name of the Guide: Mrs. Vanathi Ganga - Senior Manager Human Resource

ROLLING MILL DIVISION/STEEL MAKING DIVISION

106/109, BR Kandigai PO, Gummidipoondi, Thiruvallur

Her Summer Internship is found to be useful in the relevant Business. During her Summer Internship, we found her Good at Internship work. She has submitted a copy of her study report.

We wish her all success in her future endeavor.

FOR KAMACHI INDUSTRIES LIMITED

Vanathiganga – Senior Manager Human Resource

Date: 31.07.2019

Place: Gummidipoondi

KAMACHI INDUSTRIES LIMITED,
106, 109, B.R. KANDIGAI (V)
S.R. KANDIGAI (PO),
GUMMIDIPOONDI-601 201,
THIRUVALLUR DIST, T.N.



Kamachi Industries Limited

Corporate Office

ABC Trade Centre, 3rd Floor, (Inside Devi Theatre Complex)
Old No. 50, New No. 39, Anna Salai,
Chennai - 600 002. India.
Tel : +91-044-42961100, Fax : +91-044-42961122
Customer Care: 77000 67000
Mail : info@kamachigroup.com | sales@kamachitmt.com
www.kamachitmt.com www.kamachigroup.com

Manufacturing Unit

Survey No. 86, 115-119, 123,
Pathapalayam Village, Gummidipoondi - 601 201.
Tamil Nadu, INDIA.
Tel : +91-044-27967500, Fax : +91-044-27924614
CIN : U27106TN2003PLC051727
GST : 33AACCK6172C1ZW



KAMACHI GROUP

Date: 31/07/2019

TO WHOMSOEVER IT MAY CONCERN

This letter is to certify that Ms. Ashwini. K (180292601013), MBA student of B.S. Abdur Rahman Crescent Institute of Science and Technology, Vandalur, has successfully completed her internship program of 60 days with Sodexo Technical Services under the department of Human Resource Management Function. Her internship tenure was from 03.06.2019 to 31.07.2019.

During the tenure, we found her punctual and hardworking.

We wish her a bright future.

For Sodexo Technical Services Ind Pvt Ltd

Authorized Signatory



Sodexo Technical Services India Pvt. Ltd.

(Formerly known as MacLellan Integrated Services India Private Limited)

Registered Office:

1st floor, Gemstar Commercial Complex, Ramchandra Lane Extn., Kanchpada, Malad (West), Mumbai - 400 064, India.
Tel: +91 22 4421 4421 | Fax: +91 22 4421 4422 | CIN: U74999MH2006PTC246150

Block Office:

Block 5A, Fifth Floor, "Centennial Square", Off Dr. Ambedkar Road, Kodambakkam, Chennai - 600 024, India.
Tel: +91 (44) 7101 6101

www.sodexo.com



DONG - A INDIA AUTOMOTIVE PVT. LIMITED

Old No. 101, New No. 55, Thandalam Village, Sriperumbudur Taluk, (Via) Kanchipuram Dist.
Pincode - 602 105, Tamil Nadu, India. Phone : +91 - 44 - 37106003
Fax : +91 - 44 - 27156354 CIN No. : U35914TN2002PTC049010



100 PPM Certified

Date: 08-08-19

Place: Chennai

CERTIFICATE FOR INTERNSHIP

This is certified that / Mr. Asarudeen H

Student of MBA Reg: 180292601012, from B.S ABDUR RAHAMAN CRESCENT INSTITUTE OF SCIENCE AND TECHNOLOGY, vandalur. He has completed his 60 days from (07-06-19 to 07-08-19). Internship program at DONG A INDIA AUTOMOTIVE PVT.LTD. During the period of internship he worked in department of logistics DONG A INDIA AUTOMOTIVE PVT.LTD. He was found punctual , ambitious and hard working.

During the course of training, he was good and shown their interest in his learning work.

We wish him every success in life.

For DONG-A india automotive pvt ltd.





KSL/HRD/TRN/2019/ ISO 9001:2015/ OHSAS 18001:2007/ISO: 14001, UK CARES certification Surveillance audit for QMS 9001:2015 and BS 4449:2005 B500B

Sub: Completion of Summer Internship 11th June to 31st July 2019.

TO WHOMSOEVER IT MAY CONCERN

This is to Ms. Arockia Celestina N, Registration No: (180292601009), Second Year (II), Management Studies - MBA, B.S. Abdur Rahman, Crescent Institute of Science & Technology, has successfully completed Summer Internship with us as per the following details:

Duration of the Project: 11/06/2019 To 31/07/2019

Topic: A STUDY ON EMPLOYEES RETENTION IN KAMACHI INDUSTRIES LIMITED.

Name of the Guide: Mrs. Vanathi Ganga - Senior Manager Human Resource

ROLLING MILL DIVISION/STEEL MAKING DIVISION

106/109, BR Kandigai PO, Gummidipoondi, Thiruvallur

Her Summer Internship is found to be useful in the relevant Business. During her Summer Internship, we found her Good at Internship work. She has submitted a copy of her study report.

We wish her all success in her future endeavor.

FOR KAMACHI INDUSTRIES LIMITED

Vanathiganga – Senior Manager Human Resource

Date: 31.07.2019

Place: Gummidipoondi



KAMACHI INDUSTRIES LIMITED

106, 109, B.R. KANDIGAI (V)

S.R. KANDIGAI (PO),

GUMMIDIPOONDI-601 201.

THIRUVALLUR DIST, T.N.

Manufacturing Unit

Survey No. 86, 115-119, 123,

Pathapalayam Village, Gummidipoondi - 601 201.

Tamil Nadu, INDIA.

Tel : +91-044-27967500, Fax : +91-044-27924614

CIN : U27106TN2003PLC051727

GST : 33AACCK6172C1ZW

Kamachi Industries Limited

Corporate Office

ABC Trade Centre, 3rd Floor, (Inside Devi Theatre Complex)

Old No. 50, New No. 39, Anna Salai,

Chennai - 600 002, India.

Tel : +91-044-42961100, Fax : +91-044-42961122

Customer Care: 77000 67000

Mail : info@kamachigroup.com | sales@kamachitmt.com

www.kamachitmt.com www.kamachigroup.com



KAMACHI GROUP



KSL/HRD/TRN/2019/ ISO 9001:2015/ OHSAS 18001:2007/ISO: 14001, UK CARES certification Surveillance audit for QMS 9001:2015 and BS 4449:2005 B500B

Sub: Completion of Summer Internship 11th June to 31st July 2019.

TO WHOMSOEVER IT MAY CONCERN

This is to Ms. Arockia Celestina N, Registration No: (180292601009), Second Year (II), Management Studies - MBA, B.S. Abdur Rahman, Crescent Institute of Science & Technology, has successfully completed Summer Internship with us as per the following details:

Duration of the Project: 11/06/2019 To 31/07/2019

Topic: A STUDY ON EMPLOYEES RETENTION IN KAMACHI INDUSTRIES LIMITED.

Name of the Guide: Mrs. Vanathi Ganga - Senior Manager Human Resource

ROLLING MILL DIVISION/STEEL MAKING DIVISION

106/109, BR Kandigai PO, Gummidipoondi, Thiruvallur

Her Summer Internship is found to be useful in the relevant Business. During her Summer Internship, we found her Good at Internship work. She has submitted a copy of her study report.

We wish her all success in her future endeavor.

FOR KAMACHI INDUSTRIES LIMITED

Vanathiganga – Senior Manager Human Resource

Date: 31.07.2019

Place: Gummidipoondi



KAMACHI INDUSTRIES LIMITED

106, 109, B.R. KANDIGAI (V)

S.R. KANDIGAI (PO),

GUMMIDIPOONDI-601 201.

THIRUVALLUR DIST, T.N.

Manufacturing Unit

Survey No. 86, 115-119, 123,

Pathapalayam Village, Gummidipoondi - 601 201.

Tamil Nadu, INDIA.

Tel : +91-044-27967500, Fax : +91-044-27924614

CIN : U27106TN2003PLC051727

GST : 33AACCK6172C1ZW

Kamachi Industries Limited

Corporate Office

ABC Trade Centre, 3rd Floor, (Inside Devi Theatre Complex)

Old No. 50, New No. 39, Anna Salai,

Chennai - 600 002, India.

Tel : +91-044-42961100, Fax : +91-044-42961122

Customer Care: 77000 67000

Mail : info@kamachigroup.com | sales@kamachitmt.com

www.kamachitmt.com www.kamachigroup.com



KAMACHI GROUP



SAR WORLDWIDE LOGISTICS PVT. LTD.,

International Couriers & Cargo Forwarders

July 31st 2019

TO WHOMSOEVER IT MAY CONCERN

This is to certify that Mr. N.ARUN KUMAR (Regn. No. : 180292601010) from B.S. ABDUR RAHMAN CRESCENT UNIVERSITY, Department of Management has successfully completed his Internship in our Concern from June 03,2019 to July 31,2019. We wish him all the very best in his future assignments.

Thanking You,

Yours truly,
For SAR WORLDWIDE LOGISTICS PVT. LTD.,



Authorised Signatory.

भारत हेवी इलेक्ट्रिकल्स लिमिटेड

(भारत सरकार का उपक्रम)

Bharat Heavy Electricals Limited

(A Govt. of India Undertaking)

Power Sector - Southern Region,

Periyar EVR Building, 690, Anna Salai,

Nandanam, Chennai - 600 035.



ISO 9001 : 2015
Certified company

PSSR:HR:508
01.08.2019

TO WHOMSOEVER IT MAY CONCERN

This is to certify that **Ms. Archana R.** (Reg. No. 180292601008) I-year MBA student of B.S. Abdur Rahman Crescent Institute of Science & Technology, has undergone summer internship at Finance & Accounts Department of PSSR, Headquarters, Chennai from 01.06.2019 to 31.07.2019.

She has been imparted training in various areas such as Commercial and Taxation.

She has diligently attended to the work allocated to her during this period and has completed her internship to our satisfaction.

We wish her a bright future.

(Ravindra Babu T)
Dy. Manager/HR

टी. रवीन्द्र बाबु
T. RAVINDRA BABU

उप प्रबंधक (मा.सं)
Dy. Manager (HR)

बी.एच.ई.एल. - पी.एस.एस.आर. / B.H.E.L. - P.S.S.R.
पेरियार ई वी आर बिल्डिंग / Periyar EVR Building
690, अन्ना साली, नन्दनम, चेन्नाई - 600 035.
690, Anna Salai, Nandanam, Chennai - 600 035.



CA. A. GUHANESWARAN FCA, I.S.A

Chartered Accountant

LL : 04362 271796

Mob: 93677 24500

E-mail : agnfca@hotmail.com

auditorguhan@gmail.com

F2, 3rd Floor, NGK Apartments, Mary's Corner, N.K. Road, Thanjavur - 613 001.

Date : 31.7.19

TO WHOM SO EVER IT MAY CONCERN

This is to certify that **Mr. Balamurali V.S (Reg.No.180292601019)**, a student of M.B.A, in B.S.Abdur Rahman Crescent Institute of Science & Technology, Vandalur, Chennai has successfully undergone his internship training during the period from 01.06.2019 to 31.07.2019 for about 2 months in our office.

During the internship period he has been given training in the areas of,

- > Bank Concurrent Audits
- > Interest Verification for Jewel Loans for subsidy purpose
- > Office Management

His involvement in the work, co-operation with other staff and understanding of the work is fully satisfied.

During the training period, he was very much focussed in the work given to him. We wish him success in all his future endeavours.

Place: Thanjavur

Date: 31.07.2019



Our Network Offices :

Pudukkottai: 3889, West Main Street (Near KLKS Thirumana Mahal) Pudukkottai - 622 001. Ph: 04322 - 228629
Tiruvavur : No. 4, Vinayaga Complex, Ellai Amman Keela Veedhi, Vijayapuram, Tiruvavur - 610 001. Ph: 04366 225956
Tiruchy : Second Floor A, Ragavendra Block, S.B.O Colony, Cantonment, Tiruchy - 620 001. Ph: 0431-2401611



01.08.2019

COMPLETION CERTIFICATE

This is to certify that Mr.K.Dinesh, Reg. No: 180292601023 of M.B.A department in B.S.ABDUR REHMAN CRESCENT INSTITUTE OF SCIENCE & TECHNOLOGY has completed his summer internship training in our organization successfully during the period 01.06.2019 till 31.07.2019.

Signature of Company guide with date and seal

For RUBAN COTTAGE INDUSTRIES
Manager
01/08/2019

Ruban Cottage Industries

No.1, Narayanapuram Village,
Kavanoor Road, Arcot 632 507
P: 04172-294285 / 90470 10460

E: info@manimark.com
www.manimark.com



Ramesh Subramaniam & Co
Chartered Accountants

No.15, Padmanaba Street
T.Nagar, Chennai - 600 017
Tel.: 044 - 2834 0316, 4207 4739
email : ramesh@rsandco.org

August 02 2019

The Head of Department
MBA
B S Abdur Rahman Crescent Institute of Science and Technology
Vandalur
Chennai 600 048.

Dear Sir,

Re : Internship Training - Dhanushya S (RRN No: 180292601022)

The above mentioned student had successfully completed the internship at our Office from 3rd June 2019 to 31st July 2019.

During the above period, the student was involved in the following functions.

Recording Transactions in Tally Accounting System
GST Reconciliation using Excel

The performance of the student during the training period was **VERY GOOD**.

Wishing her the best in her future endeavors.

Sincerely yours

For RAMESH SUBRAMANIAM & Co.,
Chartered Accountants

Ramesh S
Partner
Membership No: 027522

NEDS/HR/INT-19

31-July-19

TO WHOMSOEVER IT MAY CONCERN

This is to certify that Ms.Chandhini V (Roll No :180292601021) First Year MBA student of B.S Abdur Rahman University, Chennai has successfully completed her Internship Training from 03rd June 2019 to 31st July 2019 at our Semmenchery Factory & Corporate Office Chennai.

We found her very sincere and dedicated during her Internship Training.

We wish her all the very best in her future endeavors!

For Novateur Electrical & Digital Systems Pvt Ltd,

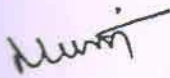

Karthikeyan M

Manager – HR

**NEW ENERGY
TO POWER**

Novateur Electrical & Digital Systems Private Limited
10th Floor, Prestige Centre Court, Office Block, Vijaya Forum Mall, 183, NSK Salai,
Arcot Road, Vadapalani, Chennai - 600 026, India | T.: + 91 44 4656 5555

Regd. Office: 61/62 6th Floor, Kalpatru Square, Kondivita Road, Off Andheri Kurta Road, Andheri (E),
Mumbai - 400059, India. | T.:+91-22-3041 6200 | Corporate Identity Number (CIN) - U31909MH2010PTC206487



RYAL
Logistics Pvt.Ltd.



Carrying Your Commitments

17th August 2019

Certificate of Completion

This is to certify that Mr. Balaji D pursuing MBA from Crescent Institute of Science & Technology Registration No. 180292601017 has done concurrent placement in our Organization from 01st June 2019 to 31st July 2019.

During the period of his Internship, he has demonstrated Good understanding of all Inco-Terms relevant to Logistic Industry and has also completed the various responsibilities given to him.

The management would like to thank him for his service with the Organization and wish him all the best in his future endeavors.

Thanking You,

For Ryal Logistics Pvt. Ltd

A. Shakuntala
Branch Manager

An ISO 9001:2015 Certified Co.

Chennai Off.: #1, Kumaran Street, 1st Floor, Meenabakkam, Chennai - 600 027.

Tel: +91-44-2256 1777 | Fax: +91-44-2256 0732 | E-mail: chennai@ryal.in | CIN # U63090MH1997PTC107821

Corporate Off.: Pramukh Plaza, 'C' Wing, 2nd. Floor, Cardinal Gracias Road, Chakala, Andheri (East), Mumbai - 400 099.

Tel.: +91-22-6193 6969 (Hunting Lines) | Fax: +91-22-6193 6999 | E-mail: info@ryal.in | Web.: www.ryal.in

MUMBAI (HO.) • NHAVA SHEVA • AHMEDABAD • BENGALURU • CHENNAI • DELHI • DAHEJ • HYDERABAD



RITU FREIGHT AND TRANSPORT SERVICE PVT. LTD.

201, Navratan Building, 69, P. D'Mello Road, Carnac Bunder, Mumbai 400 009.
Tel. No. 2348 0261 - 65 • Fax No. 2348 2233 • Email : scai.india@vsnl.com

Date: 31.07.2019

Chennai

TO WHOM SO EVER IT MAY CONCERN

This is to certify that Mr. N.R Baabulnath, studying First Year MBA in your college is permitted to do internship in the title Logistics & Supply Chain Management in our Organization for a period of two months from 07.06.2019 to 31.07.2019.

Thanking you,

For, Ritu Freight and Transport Service Pvt Ltd.

For RITU FREIGHT AND TRANSPORT SERVICES PVT. LTD.



Authorized Signatory
(Authorized Signatory)

Date : 03:06:2019

To
Head of the department
Management studies
Crescent Institute of Technology
Chennai - 16

Sub: Permission requested for summer internship HR Activities, here we declare to do Internship with our concern behalf of that we issue the confirmation letter.

Dear Ms.Sridevi M (180292601104)

Congratulations!!

We here declare to give permission to do Summer Internship confirmation with our Concern Next innovation Asia (Nia group of companies), with mentioned student name Ms.Sridevi M (180292601104) and the Internship duration is Two months (from 03.06.2019 to 31.07.2019). Based on students performance will give job or job reference to clients. With this internship training duration will give internal office safe environment but outside of premises students only responsible for his safety.

Students must bring while start project with company.

1. Address prof / id prof
2. Project confirmation letter

Looking forward to a long and mutually beneficial career with us

Yours truly,

Managing Director
Ashok Kumar
Next Innovation Asia Group of companies



30th July, 2019
Chennai

TO WHOMSOEVER IT MAY CONCERN

This is to certify that **Ms. Swedha G**, studying MBA at B.S. Abdur Rahman Crescent Institute of Science and Technology has undergone internship training in **Accounts Department** of our concern for a period starting, 6th June 2019 to 30th July 2019. The work performed by her was satisfactory. We wish her all success in her future endeavours.

for **Sundaram BNP Paribas Home Finance Ltd.**

Ganesh
Head - HR

NEDS/HR/INT-19

31-July-19

TO WHOMSOEVER IT MAY CONCERN

This is to certify that Ms.Akshaya Mohan (Roll No :180292601006) First Year MBA student of B.S Abdur Rahman University, Chennai has successfully completed her Internship Training from 03rd June 2019 to 31st July 2019 at our Semmenchery Factory & Corporate Office Chennai.

We found her very sincere and dedicated during her Internship Training.

We wish her all the very best in her future endeavors!

For Novateur Electrical & Digital Systems Pvt Ltd,



Karthikeyan M

Manager – HR

**NEW ENERGY
TO POWER**



Novateur Electrical & Digital Systems Private Limited
10th Floor, Prestige Centre Court, Office Block, Vijaya Forum Mall, 183, NSK Salai,
Arcot Road, Vadapalani, Chennai - 600 026, India | T.: + 91 44 4656 5555

Regd. Office: 61/62 6th Floor, Kalpatru Square, Kondivita Road, Off Andheri Kurla Road, Andheri (E),
Mumbai - 400059, India. | T: +91-22-3041 6200 | Corporate Identity Number (CIN) - U31909MH2010PTC206487

www.numericups.com



فليت لاين شيبينغ سيرفيسيز (ش.ذ.م.م)

FLEET LINE

SHIPPING SERVICES L.L.C.

1ST August 2019

TO WHOM SO EVER IT MAY CONCERN

This is to confirm that Mr. Adhil Mohamed, an MBA student with your esteemed institution, holding Indian Passport Number R3738642 has undergone training as an intern in our Organization from 2nd June 2019 to 31st July 2019.

During his internship he worked in various departments like Accounts, Customer Service, Freight Operations and other related departments.

He conducted himself in a professional manner and showed an aptitude to take on responsibilities and execute the jobs in an appropriate manner.

We thank him for his contribution and wish him all the best in his career.

For FLEET LINE SHIPPING SERVICES LLC

TOM JACOB

GENERAL MANAGER



HEAD OFFICE

Al Jada Tower
Marina Crown Plaza Hotel, Sheikh Zayed Road *
P.O. Box 118152, Dubai, U.A.E.
Tel +971 4 357 5562 • Fax +971 4 357 0466



www.fleetlineshipping.com

BRANCH

Warehouse and office# VE03
Between R/A 12 & 13, JAFZA
Jebel Ali, U.A.E

Tel +971 4 881 1525 • Fax +971 4 881 1526

Date: 01.06.2019

PERMISSION LETTER

To
The Head of the Department,
Department of Management Studies,
Crescent Institute of Science & Technology,
Vandalur, Chennai-600048.

Sub: Permission for Summer Project

This letter is to certify that **Mr. H. ABDUL RAHUMAN [Reg. No. 180292601002]** a student of M.B.A from "**CRESCENT INSTITUTE OF SCIENCE & TECHNOLOGY**", Chennai has been offered a Summer project internship with **AASAI PACKAGED DRINKING WATER**, Trichy under the supervision of Mr. M Srinivasan, who will be the student's supervision.

The internship programs will starts from 1st June 2019 and until the student completes the required internship hours.

For Aasai Packaged Drinking Water

Signature,

Mr. M Srinivasan

Manager-Production



Aasai Packaged Drinking Water

Kambarasampettai, Trichy, Tamil Nadu, India.



23rd June 2018

CERTIFICATE

This is to certify that **Mr MOHAMED IMRAN K M (RRF NO 150121601017)** studying **III Year B.Tech (Automobile Engineering)** in **CRESCENT Institute of Science & Technology, Vandalur, Chennai – 48.** Who carried out a **Internship Training work** in our organization between **18th June 2018 to 23rd June 2018.**

Thanking you,

Yours faithfully,

For **V3 Automotives Pvt Ltd.,**



M BALASUBRAMANIAM
(HUMAN RESOURCES)

NEW THINKING. NEW POSSIBILITIES

CERTIFICATE OF COMPLETION

This is to certify that **MOHAMED IMRAN K M, S/o.**
KHAJA MAGDOOM Z, studying in **B.S.ABDUR RAHMAN**
CRESCENT INSTITUTE OF SCIENCE AND TECHNOLOGY
of Third Year **Automobile Department,** has done
Inplant Training in **VBK MOTORS** from 25.06.2018 to
30.06.2018.

During the training period the performance of the
trainee was found to be **Good.**

Date: 30.06.2018

For VBK MOTORS

Authorised Signatory

PROGRAM CO-ORDINATOR

MOHAMED IMRAN. K. M,

RRN – 150121601017,

4TH YEAR B.TECH AUTOMOBILE ENGINEERING,

B.A. ABDUR RAHMAN CRESCENT INSTITUTE OF SCIENCE AND TECHNOLOGY.

A Short Report on Internship Programme.

I have undergone an internship programme for seven days from 18 June, 2018 to 23 June, 2018 in **V3 Automotives Pvt. Ltd.(Hyundai)**, OMR, Perungudi, Chennai. It was a good opportunity for me, where I was exposed to various works done in service centres and it was a place where I have acquired practical knowledge in-depth on types of services for a four wheeler and had a hands-on experience on various engines.

Also I have undergone another internship programme for five days from 25 July, 2018 to 30 July, 2018 in **VVK Motors(Maruti Authorised Service Station)**, Pallavaram , Chennai. This served as a platform to gain various technical knowledge about four wheeler electronics and sub systems and also helped me acquire knowledge about transmission systems of automobiles.

I like to thank my department faculty's and source given to do internship and i acquired knowledge in this internship.



To whomsoever it May concern

Date: 26.07.2018

This is the certify that Mr. R NITISH (Roll no – 170121601037)a student of B Tech (II Year), from B.S Abdul Rahman crescent institute of science and Technology has successfully completed the internship work in our organization during the period from June 20 , 2018 To July 05 2018 .

We wish Mr. R NITISH all the best in his future endeavours.

For I Speed Motors



Authorized Signatory

I SPEED MOTORS

Sales : 29/13, Medavakkam Tank Road, Ayanavaram Near ESI, Chennai-600 012.

Tel : 044-45548585 E-mail : ispedre@gmail.com, ☎ : ispeed motors

Service : No. 127-B, Bricklin Road, Purasaiwalkam, Chennai - 600 007. Near Mekala Theater

Tel : 044-45588047 Cell : 9094633715 / 9094633718 E-mail : ispedre@gmail.com

Madurai
25.06.2018

TO WHOM SO EVER IT MAY CONCERN

This is to Certify that **Mr. G.Sree Ahobilan**,
IInd Year B.E (Automobile Engineering) Student of "Crescent Institute of
Science & Technology" in Chennai was undergone "IN-PLANT
TRAINING" in our Organisation of **M/s. SUKRITH MOTORS CARS PVT LTD**
from the Period of **06.06.2018 to 23.06.18** During the course, we found his
conduct and character were good.

We wish him success in his career.

With Regards,
For SUKRITH MOTOR CARS PVT LTD

P. Karuppu Raja
SERVICE MANAGER

NEW THINKING. NEW POSSIBILITIES.

Sukrith Motor Cars Pvt Ltd

HO : 4 / 113-H Ring Road, Uthangudi, Madurai - 625 107.

Tel : +91 0452 4260100 Fax : +91 0452 4219021

BO. : Kovilur Road, Near Old Bus Stand, Karaikudi - 630 001.

Tel : +91 04565 400111

sales@sukrith.in sukrith.hyundaimotor.in



Ramani Cars Private Limited, 54/1, Mettupalayam Road, Kovundampalayam, Coimbatore - 641030.
CIN NO IS: U50101TZ2009PTCO15058

07.01.2019

TO WHOM SO EVER IT MAY CONCERN

Date

This is to certify that **Mr. A. Karthick Akaash (150121602004)**, Student of Present Engineering Collage, Chennai has undergone his Internship Training in our concern during the period from 24.12.2018 to 02.01.2019.

Volkswagen Coimbatore
Ramani Cars Private Limited,
54/1, Mettupalayam Road,
Kovundampalayam,
Coimbatore - 641030.
Phone 91 - 422 - 4600000
Email: sales@vw-ramanicars.co.in
Website: www.vw-ramanicars.co.in
CIN NO IS: U50101TZ2009PTCO15058
Unit Certified By EMS

He has been regular and shown keen interest in the assignment and his conduct and character were good.

We wish him all the best for future endeavor.

Ramani Cars Private Limited

Sankar Nagaraj K S
Manager - HR



LANSON TOYOTA

34, Poonamallee High Road,
Koyambedu, Chennai - 600 107.

Sales & Service: 4000 8000

Fax : 3960 5072

To
The HOD,
BS ABDUR RAHMAN CRESCENT INSTITUTE OF SCIENCE & TECHNOLOGY
Vandalur
Chennai - 600 048

Sub: Permission to do Internship.

Dear Sir,

I am pleased to confirm the Internship for Mr. R. NITISH (Reg.No:170121601037) II year B.Tech Automobile Engineering in our organization at KOYAMBEDU Unit from 15th December 2018 to 22nd December 2018.

During the said period the student will not be eligible for any stipend or other benefits and will be governed by the Rules and Regulations of our organization.

A copy of the Internship report has to be submitted to us at the end of the tenure.

Form Lanson Motors Private Limited.

Sankar P

Group Head- Human Resource

Volkswagen Tirunelveli



Ramani Cars Private Limited, 380/3B1J, Malliha Colony, Madurai to Nagerkovil 4 way, Near Rettiarpatti Hills, Maharaja Nagar (PO), Tirunelveli-627011.

Date

30.06.18

TO WHOM SO EVER IT MAY CONCERN

This is to certify that Mr. Ashwin Karthikeyan. B.E. Mechanical engineering student of .B.S Abdur Rahman Crescent of Science & Technology Technology has undergone his Internship Training during the period from 01.05.2018 to 30.06.2018.

Volkswagen Tirunelveli
Ramani Cars Private Limited,
380/3B1J, Malliha Colony,
Madurai to Nagerkovil 4 way,
Near Rettiarpatti Hills,
Maharaja Nagar (PO),
Tirunelveli-627011.
Phone 91-462-3014000

Those has been regular and shown keen interest in the assignment and his conduct and character were good.

We wish him all Success in his Future endeavors.

VW Ramani Cars Pvt. Ltd.

B.M Senthil Kumar, 20/09/2018

Service Manager



RENAULT
Passion for life

DATE : 11/01/2019

CERTIFICATE

This is to certify that **Mr.R.ASHWIN KARTHIKEYAN** has worked as intern in **ARASPVPV AUTOMOBILES PVT LTD** as technician from **07/01/2019** to **11/01/2019** for a period of **5** days. During this period his Conduct and Character was **Good**.

For AR.A.S.P.V.P.V.AUTOMOBILES PVT LTD

MANAGER- SERVICE



RENAULT Tirunelveli
AR.A.S.P.V.P.V. Automobiles Private Limited
10-D, Trivandrum Road, Palayamkottai, Tirunelveli - 627002
Tel : 0462 - 2501355
E-mail : sales.tirunelveli@renault-india.com

ASHWIN KARTHIKEYAN.R

RRN: 150121601007

4th year, Department Of Automobile

B.S.ABDUR RAHUMAN CRESCENT INSTITUTE OF SCIENCE AND TECHNOLOGY

A SHORT REPORT OF MY INTERNSHIP PROGRAMME

I have pursued internship training in Volkswagen Tirunelveli, Ramani Cars pvt.ltd during the period from 01.05.2018 to 30.06.2018. It was a great opportunity for me to do four weeks intern. The objective of this internship is to gather information about the quick services and the major-minor problem that can be observed in day to day life..As I have been an intern there for nearly one month I learnt new hands-on experiences likely been through general checkups section. That was my first lesson I have learnt from. Secondly, I could say that I've studied about EGR (Exhaust Gas Recirculation) behind the reason for the cause of the white smoke getting exhausted. Finally I have gone through the fuel mixing that has gone a major fault that made engine nearly to get ceased.

Also I have undergone internship training in Renault Trunelveli, A.R.A.S.P.V.P.V. Automobile pvt.Ltd. during the period from 07.01.2019 to 11.01.2019 for a periods of 5 days. It was a great opportunity for me to do four weeks intern. The objective of this internship is to gather information about the quick services and the major-minor problem that can be observed in day to day life. I have been through the hands-on experiences on disassembling and assembling of brake pads as well as disc brakes.

At last this internship has given me new insights and motivation to pursue a career in automobile engineering.



TO WHOMSOEVER IT MAY CONCERN

This is to certify that Mr. Niranjana Christopher L, B.Tech Mechanical Engineering student from B S Abdur Rahman Crescent University, Institute of Science & Technology Vandalur, Chennai – 600 048, has undergone the internship program from 16/01/2018 to 23/02/2018 at Festo India Private Limited.

Dated

23/02/18

During his Internship training, he has interacted with Ms. Archana Hosamani, Senior Officer – Logistics, Mr. Sathish ES, Assistant Manager - Quality & Mr. Pradeep Venkatesh, Manager – Lean Management and he has worked on the below project,

Our Reference

18/03/AOS

1. Optimization of Material Supply in Plant – 3 Logistics.
2. Identification of Possible Safety Hazards in all the Production Fixtures.

Your Reference

Mr. Niranjana Christopher L has successfully completed the internship program and we have found him sincere, open to learnings and punctual during his Internship.

We wish Mr. Niranjana Christopher L all the very best in his future endeavours.

For Festo India Private Limited

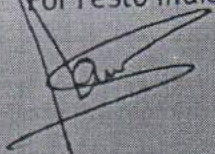

Arun Sosle

Head – Manufacturing

Global Production Centre

Festo India Private Limited
(Formerly Festo Controls Private Limited)

Global Production Centre
225 & 226,
Bommasandra Industrial Area
Off Hosur Road
Bengaluru - 560 099, India

Tel : +91 80 2289 4100
Fax: +91 80 2783 2058
E-mail : hgpc_reception@festo.com
Website : www.festo.in

Registered Office
237B, Bommasandra Industrial Area
Hosur Road,
Bengaluru - 560 099, India
CIN: U29220KA1964PTC007449

FESTO**TO WHOMSOEVER IT MAY CONCERN**

This is to certify that Mr. Riyaz Ahmed, B.Tech Mechanical Engineering student from B S Abdur Rahman Crescent University, Institute of Science & Technology Vandalur, Chennai - 600 048, he has undergoing the internship program from 16 /01/2018 to 23/02/2018 at Festo India Private Limited.

Dated

23/02/18

During his Internship training, he has interacted with Ms. Snehal VC, Engineer - Data Management, Mr. Govind Mayya, Manager - Production, Mr. Shanmugam Raja, Supervisor & Mr. Pradeep Venkatesh, Manager - Lean Management and he has worked on the below project,

Our Reference

1. Implementation of Kanban for Inputs Material of Robodrill Machine
2. Production Study of Piston Rods Cutting and Turning of Piston Rods.

18/08/AOS

Your Reference

Mr. Riyaz Ahmed has successfully completed the internship program and we have found him sincere, open to learnings and punctual during his Internship.

We wish Mr. Riyaz Ahmed all the very best in his future endeavours.

For Festo India Private Limited



Arun Sosle

Head - Manufacturing

Global Production Centre

Festo India Private Limited
(Formerly Festo Controls Private Limited)
Global Production Centre
 225 & 226,
 Bommasandra Industrial Area
 Off Hosur Road
 Bengaluru - 560 099, India

 Tel : +91 80 2789 4100
 Fax : +91 80 2783 2058
 E-mail : ingpc_reception@festo.com
 Website : www.festo.in
Registered Office
 237B, Bommasandra Industrial Area
 Hosur Road,
 Bengaluru - 560 099, India
 CIN: U29220KA1986PTC007449

TO WHOMSOEVER IT MAY CONCERN

FESTO

This is to certify that Mr. Imran Shaik, B.Tech Mechanical Engineering student from B S Abdur Rahman Crescent University, Institute of Science & Technology Vandalur, Chennai - 600 048, he has undergone the internship program from 16 / 01/2018 to 23/02/2018 at Festo India Private Limited.

During his Internship training, he has interacted with Mr. Abhiflash Nagaraju, Assistant Manager - Logistics, Ms. Sreelaxmi Katte, Team Lead & Mr. Pradeep Venkatesh, Manager - Lean Management and he has worked on the below project,

1. Implementation of Kanban for Common Parts in Cylinder Assembly Lines.
2. Production Study of Three Cylinder Assembly Lines.

Mr. Imran Shaik has successfully completed the Internship program and we have found him sincere, open to learnings and punctual during his Internship.

We wish Mr. Imran Shaik all the very best in his future endeavours.

For Festo India Private Limited

Arun Sosle

Head - Manufacturing
Global Production Centre

Dated

23/02/18

Our Reference

18/06/AOS

Your Reference

Festo India Private Limited
(Formerly Festo Controls Private Limited)

Global Production Centre
225 & 226,
Bommasandra Industrial Area
Off Hosur Road
Bengaluru - 560 099, India

Tel : +91 80 2289 4100
Fax : +91 80 2284 2020
E-mail : hr@india.private.festo.com
Website : www.festo.in

Registered Office

237B, Bommasandra Industrial Area
Hosur Road
Bengaluru - 560 099, India
CIN: U29220RA180011001A42



GATES UNITTA

GATES UNITTA INDIA COMPANY PVT. LTD.
F-19, SIPCOT INDUSTRIAL PARK, PONDUR A
SRIPERUMBUDUR, KANCHIPURAM DISTRICT,
TAMIL NADU 602 106, INDIA
TEL : 91 44 47115100
GATES.COM/INDIA
CIN : U25192TN2002PTC049526

GUIC/IP/Aug 2018

07.08.2018

TO WHOMSOEVER IT MAY CONCERN

This is to certify that **Mr. R. Ganapathy Vishal (RRN No: 150021601045)**, student of Final Year Bachelor of Engineering (Mechanical) from **BS Abdur Rahman Crescent Institute of Science and Technology**, Chennai has successfully completed his In plant training at our plant during the period **July 3, 2018 to July 17, 2018**.

During the training period, his level of commitment, involvement and attitude were found to be good.

We wish him all the best in his future endeavors.

For Gates Unitta India Company Private Ltd.,

I Meenakshi Sundaram

Director – Technical & Commercial



GATES UNITTA

GATES UNITTA INDIA COMPANY PVT. LTD.
F-19, SIPCOT INDUSTRIAL PARK, PONDUR A,
SRIPERUMBUDUR, KANCHIPURAM DISTRICT,
TAMIL NADU-602 106, INDIA
TEL : 91 44 47115100
GATES.COM/INDIA
CIN : U25192TN2002PTC049526

GUIC/IP/Aug 2018

07.08.2018

TO WHOMSOEVER IT MAY CONCERN

This is to certify that **Mr. R. Ganapathy Vishal (RRN No: 150021601045)**, student of Final Year Bachelor of Engineering (Mechanical) from **BS Abdur Rahman Crescent Institute of Science and Technology**, Chennai has successfully completed his In plant training at our plant during the period **July 3, 2018 to July 17, 2018**.

During the training period, his level of commitment, involvement and attitude were found to be good.

We wish him all the best in his future endeavors.

For Gates Unitta India Company Private Ltd.,

I Meenakshi Sundaram

Director – Technical & Commercial



GATES UNITTA

GATES UNITTA INDIA COMPANY PVT. LTD.
F-19, SIPCOT INDUSTRIAL PARK, PONDUR A,
SRIPERUMBUDUR, KANCHIPURAM DISTRICT,
TAMIL NADU-602 106, INDIA
TEL : 91 44 47115100
GATES.COM/INDIA
CIN : U25192TN2002PTC049526

GUIC/IP/Aug 2018

07.08.2018

TO WHOMSOEVER IT MAY CONCERN

This is to certify that **Mr. S. Shrinivasan** (RRN No: 150021601160), student of Final Year Bachelor of Engineering (Mechanical) from **BS Abdur Rahman Crescent Institute of Science and Technology**, Chennai has successfully completed his In plant training at our plant during the period **July 3, 2018 to July 17, 2018**.

During the training period, his level of commitment, involvement and attitude were found to be good.

We wish him all the best in his future endeavors.

For Gates Unitta India Company Private Ltd.,

I Meenakshi Sundaram

Director – Technical & Commercial

Brakes India Private Limited

Padi, Chennai 600 050

Telephone : (044) 2625 8161, 2652 6000

Fax : (044) 2625 7010, 2625 7844

Web : www.brakesindia.com

CIN : U35999TN1962PTC004928

Friday, December 14, 2018

C E R T I F I C A T E

This is to certify that **Mr V Ram Prakash**, B.E (Mechanical)
Student of **Crescent Institute of Science & Technology -**
Chennai has done his '**Inplant Training**' in our Organization
from 10.12.2018 to 14.12.2018.

He has evinced keen interest in learning.

We wish him success in all his future endeavors.

N Lakshminarasimhan
N Lakshminarasimhan
General Manager - HR



Brakes India Private Limited

Padi, Chennai 600 050

Telephone: (044) 2625 8161, 2652 6000

Fax : (044) 2625 7010, 2625 7844

Web : www.brakesindia.com

CIN : U35999TN1962PTC004928

Friday, December 14, 2018

C E R T I F I C A T E

This is to certify that **Mr A N Saravanan**, B.E (Mechanical)
Student of **Crescent Institute of Science & Technology -**
Chennai has done his '**Inplant Training**' in our Organization
from 10.12.2018 to 14.12.2018.

He has evinced keen interest in learning.

We wish him success in all his future endeavors.

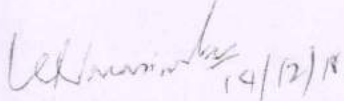
N Lakshminarasimhan
General Manager – HR



Dec 29, 2017

HR /12/ TR125

TO WHOMSOEVER IT MAY CONCERN

This is to certify that Mr.Shakthi Gowtham M a student of BS Abdur Rahman Crescent University - Vandaloor, has successfully completed his inplant training during the period from 26th Dec, 2017 to 29th Dec, 2017.

During the training period, his level of commitment, involvement and attitude were found to be good.

We wish Mr.SHAKTHI GOWTHAM M, all the best in his future endeavors.

For HYUNDAI MOTOR INDIA LIMITED

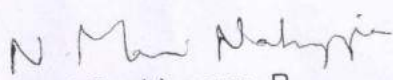
Mani Nachiappan
Learning & Development



HR /3/ TR44

Mar 16, 2018

TO WHOMSOEVER IT MAY CONCERN

This is to certify that Mr.Faizal K a student of B.S.Abdur Rahman Crescent Institute of Science and Technology - Vandalur, has successfully completed his inplant training during the period from 12th Mar, 2018 to 16th Mar, 2018.

During the training period, his level of commitment, involvement and attitude were found to be good.

We wish Mr.FAIZAL K, all the best in his future endeavors.

For HYUNDAI MOTOR INDIA LIMITED

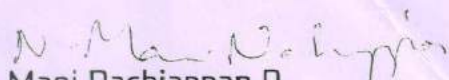
Mani Nachiappan
Learning & Development



ASHOK LEYLAND

Aapki Jeet. Hamari Jeet.

CERT. No: HRD/T&D/1811

29th DEC 2018

TO WHOM SO EVER IT MAY CONCERN

This is to certify that **Mr. U K JAWAHAR PRANAV** Student,
"CRESCENT INSTITUTE OF SCIENCE & TECHNOLOGY" has done his In-
plant Training at ASHOK LEYLAND Ltd, ENNORE, Chennai, from 26.12.2018 to
29.12.2018 successfully.

His conduct and character during the period of training was found to be good.

S. THANGAVEL 28/12/18
SENIOR MANAGER (L&D)



ASHOK LEYLAND LIMITED
Ennore, Chennai - 600 057, India. T : +91 44 25759444 / 466 F: +91 44 25752273
Registered & Corporate Office: No. 1, Sardar Patel Road, Guindy, Chennai - 600 032, India
T : +91 44 2220 6000 | F : +91.44.2220 6001 | www.ashokleyland.com



HINDUJA GROUP



ASHOK LEYLAND

Aapki Jeet. Hamari Jeet.

CERT. No: HRD/T&D/1812

29th DEC 2018

TO WHOM SO EVER IT MAY CONCERN

This is to certify that **Mr. M SHAKTHI GOWTHAM** Student,
**"B S ABDHUR RAHUMAN CRESCENT INSTITUTE OF SCIENCE &
TECHNOLOGY"** has done his In-plant Training at **ASHOK LEYLAND Ltd,**
ENNORE, Chennai, from 26.12.2018 to 29.12.2018 successfully.

His conduct and character during the period of training was found to be good.

S. THANGAVEL
SENIOR MANAGER (E&D)



ASHOK LEYLAND LIMITED

Ennore, Chennai - 600 057, India. T : +91 44 25759444 / 466 F: +91 44 25752273
Registered & Corporate Office: No. 1, Sardar Patel Road, Guindy, Chennai - 600 032, India
T : +91 44 2220 6000 | F : +91.44.2220 6001 | www.ashokleyland.com



HINDUJA GROUP

**RENAULT NISSAN TECHNOLOGY &
BUSINESS CENTRE INDIA PRIVATE LIMITED**

Certificate of Appreciation



**Special Contribution on Input Convergence
for Renault Nissan Alliance**

Sheik Muhammed Zubair

*In appreciation for your initiatives and involvement
for Successful Project Completion*

Congratulations

*&
All the best*

Namunan Saravanamuthu
HOD - Global After Sales1

09/11/2017

RENAULT · NISSAN
JOINT VENTURE COMPANY

Gmmco

CAT

Gmmco Limited

CK Birla Group
No.6, G.S.T. Road, St. Thomas Mount,
Chennai - 600 016.

29th June, 2017

To,
Head of the Department
B.S.Abdur Rahman University, Chennai.

Dear Sir / Madam,

Sub : Internship

This is to certify that **Mr. M. Shakthi Gowtham**, has undergone his **Internship** in our organization from **01.06.17 to 29.06.17**.

During the training his conduct was good and we expect this training will help him in his career.

For GMMCO Limited

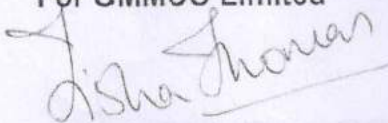

Tisha Elizabeth Thomas
Sr. Manager - HR



School of Computer Science and Engineering

Reg. No. 200604393R

July 31, 2017

NT ROASHAN
B.S. Abdur Rahman Crescent University
Chennai, India.

Dear Roashan,

Sub: Letter of Evaluation

This is with reference to the Global Academic Internship Programme (GAIP) conducted by Corporate Gurukul from 5th June, 2017 to 30th June, 2017 at Nanyang Technological University (NTU), Singapore on 'Big Data Analytics using Artificial Neural Networks'. The scope of work during internship included the following:

1. Fundamentals of Neural Networks and its Learning algorithms
2. Different types of Supervised and Unsupervised Learning algorithms
3. Online and Sequential Learning
4. Advanced topics in Machine Learning
5. Complex Value Neural Networks

Your performance was evaluated based on theoretical understanding and application of concepts in practical data analysis and was found to be SATISFACTORY with GRADE C+.

I encourage you to further your knowledge, skills and research in the above areas and wish you the very best for a career ahead!

Sincerely

A handwritten signature in black ink, appearing to read 'S. Suresh'.

Prof. Sundaram Suresh
Cluster Director ERI@N
Deputy Director, Robotics and Research Centre
School of Computer Science and Engineering
Nanyang Technological University (NTU), Singapore

50 Nanyang Avenue, Blk N4 #02a-32, Singapore 639799

Tel: +65 6790 5786 Fax: +65 6792 6559

www.ntu.edu.sg

A School of the College of Engineering

30th June, 2018

TO WHOMSOEVER IT MAY CONCERN

This is to certify that **Mr. M. Shakthi Gowtham**, student of B. S. Abdur Rahman Crescent Institute of Science & Technology, Chennai, Tamil Nadu has completed his Internship from **11th June, 2018 to 30th June, 2018** under the guidance of Mr. Debesh Rath - Technology department in Carraro India Pvt. Ltd.

This letter is being issued as per his own request.

We wish him all the success in his future endeavors.

For Carraro India Pvt. Ltd.

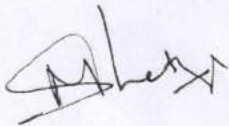

Mangesh Shetye
General Manager - Human Resource



Debesh Rath
General Manager - Technology

BMW
Plant Chennai



Your message dated 23rd March, 2018
Department/From TV-436
Telephone +91-44-47444310
Fax +91-44-47444201
E-mail Indraneel.Saha@bmw.in
Date 23rd March
Subject **Internship Completion Letter**

To whomsoever it may concern

This is to certify that **Mr. Ifraz Ahamed S** from **B.S. Abdur Rahman Crescent University** has completed his Internship in our organization from **22 January 2018 to 23 March 2018**

We wish him all success for his future endeavours.

Thank you,

On behalf of **BMW India Pvt. Ltd.**

Company
BMW India
Private Limited

A BMW Group Company

Postal address
BMW India
Private Limited
Plant Chennai
No.36, 1st Cross Road
1st Main Road
Off 2nd Avenue
Mahindra World City
Natham Sub Post
Chengalpet 603 004
Kancheepuram District,
Tamil Nadu, India

Telephone
+91 44 47444 200

Fax
+91 44 47444 201

Corporate Identity Number
J35991HR1997PTC037496

Registered office
DLF Cyber City, Phase II
Building No. B
Tower B, 7th Floor
Gurgaon 122002
Haryana, India

Bank details
Citibank India
520115001
IFSC-Code
CITI0000002

Sweta Singh
Human Resources

Received & accepted



Mahindra & Mahindra Ltd.
Mahindra Towers, Akurli Road, Kandivali (East) Mumbai 400 101 India
mahindra.com
Regd. Office
Gateway Building, Apollo Bunder
Mumbai 400 001 India

Date: 04/05/2018

Mr. Ajay Krishna R
B S Abdur Rahman Crescent Institute of Science and Technology

Sub: - Internship

Dear Ajay,

This is with reference to your application for an Internship in our organization as a part of your curriculum.

We are pleased to offer you a Project in our organization commencing from 04/06/2018 to 03/08/2018 at Mahindra and Mahindra Limited Automotive Division Chennai. The details of the project would be given to you at the time of reporting.

- During this period it is expected that you will abide by the rules and procedures of the Company.
- You will, at all times, observe secrecy and confidentiality and will not divulge, disclose or make known to any unauthorized person within or outside the Company, nor will you unauthorized use any knowledge or information in respect of manufacturing, technical trade or business data (including manufacturing processes, technical know-how, customer information, business plans and like matters) which are necessarily confidential and have come to your knowledge and possession.
- You will also not remove any such information in any form whatsoever from the Company premises, nor copy or transmit the same in an unauthorized manner through any medium including social networking networks/ public sites nor will you grant permission to assist, permit entry to, or in any manner co-operate with any unauthorized person for the purposes of accessing, obtaining, copying, transmitting or removing the above. Even after the cessation of your employment with the Company, you will not use, divulge, disclose or remove in any manner whatsoever confidential information of the type described above of which you were in possession whilst in service to the detriment of the Company.
- You will also observe all the confidentiality measures which are in existence, or which may be enforced from time to time, as well as directions as to confidentiality marked on any communication, document, electronic data storage device etc. You shall indemnify and hold Company harmless and indemnified against any damage or loss caused to the Company on account of breach of confidentiality on your part. These confidentiality provisions shall survive the separation of your employment with the Company, either by way of retirement or termination or otherwise.

CIN:L65990MH1945PLC004558



Mahindra & Mahindra Ltd.
Mahindra Towers, Akurli Road, Kandivali (East) Mumbai 400 101 India
mahindra.com
Regd. Office
Gateway Building, Apollo Bunder
Mumbai 400 001 India

- In addition to your fulfilling the requirements of secrecy and confidentiality, as specified herein, also during your project with the Company, you shall not engage in any vocation, training, employment, consultancy, business, transaction, or any other activity, which is in conflict with the interests of the Company, in any capacity whatsoever either on your own or in association with any other individual/firm/institute/body corporate, etc., whether for any consideration or not.
- You will assign to the Company your entire right, title and interest in any Intellectual Property Rights (IPRs for short, which term would include patents, trade-marks, copyrights, designs, whether registered or not, and all improvements thereto) that you may make, solely or jointly with others, in the course of your project with the Company relating to any or all systems, services and products manufactured or marketed or leased or developed. You will perform all necessary acts and execute such documents in such format as may be required by the Company, without expense to you, which in the judgment of the Company or its Attorneys may be necessary or desirable to secure to the Company full right title and interest in the IPRs.
- The Company shall at all times have the right to access and monitor all e-mails created, sent / received or stored by you using Company facility and on Company's system at any time without giving you any prior notification. All such data and information shall be the property of the Company at all times.
- You shall endeavor to uphold the good image of the Company and shall not by your conduct adversely affect the reputation of the Company and bring disrepute to the Company, in any manner whatsoever.
- Under no circumstance shall the Company be liable for any losses to you due to accidents or casualties during your project.

Please sign the duplicate copy of this letter and forward the same to us within a week's time as a token of your acceptance of the above mentioned terms and conditions of the Project.

This is a system generated document and does not require signatures, the authenticity of this document can be verified by writing to the following email ID: hrrsupport@mahindrampeople.com

CIN:L65990MH1945PLC004558



INDIAN INSTITUTE OF INFORMATION TECHNOLOGY
DESIGN AND MANUFACTURING, KANCHEEPURAM
CHENNAI-600127

MHRD Teaching Learning Centre for Design & Manufacturing Education

Certificate of Internship

This is to certify that Mr/Ms MOHAMED ASLAM NOORANI of
B. S ABDUR RAHMAN CRESCENT INSTITUTE OF SCIENCE & TECHNOLOGY has completed the
internship on CNC BASED PCB MILLING MACHINE during Feb - Apr, 2018
in the Teaching Learning Centre at our institute.

MHRD Teaching Learning Centre,
For Design and Manufacturing Education
Indian Institute of Information Technology,
Design and Manufacturing, Kancheepuram
Melakottaiyur, Chennai - 600 127

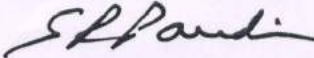
Dr. S. R. Pandian
Coordinator & Dean (Planning)



INDIAN INSTITUTE OF INFORMATION TECHNOLOGY
DESIGN AND MANUFACTURING, KANCHEEPURAM
CHENNAI-600127

MHRD Teaching Learning Centre for Design & Manufacturing Education

Certificate of Internship

This is to certify that Mr/Ms FATIMA IREANA of

B. S. ABDUR RAHMAN CRESCENT INSTITUTE OF SCIENCE & TECHNOLOGY has completed the

internship on CNC BASED PCB MILLING MACHINE during Feb - Apr, 2018

in the Teaching Learning Centre at our institute.

MHRD Teaching Learning Centre,
For Design and Manufacturing Education
Indian Institute of Information Technology
Design and Manufacturing, Kancheepuram
Melakottaiyur, Chennai - 600 127

Dr. S. R. Pandian
Coordinator & Dean (Planning)



INDIAN INSTITUTE OF INFORMATION TECHNOLOGY
DESIGN AND MANUFACTURING, KANCHEEPURAM
CHENNAI-600127

MHRD Teaching Learning Centre for Design & Manufacturing Education

Certificate of Internship

This is to certify that Mr/Ms MOHAMED ASLAM NOORANI of
B.S ABDUR RAHMAN CRESCENT INSTITUTE OF SCIENCE & TECHNOLOGY has completed the
internship on CNC BASED PCB MILLING MACHINE during Feb - Apr, 2018
in the Teaching Learning Centre at our institute.

MHRD Teaching Learning Centre,
For Design and Manufacturing Education
Indian Institute of Information Technology,
Design and Manufacturing, Kancheepuram
Melakottaiyur, Chennai - 600 127

Dr. S. R. Pandian
Coordinator & Dean (Planning)

Ch.P.T. Item Code No. C 81804355
500 Pads. Dt. 22-6-2017



Port
Par-Excellence

चेन्नै पोर्ट ट्रस्ट

CHENNAI PORT TRUST

Fax : 044 - 25361228
Phone: 044 - 25362201

प्रशासनिक कार्यालय
ADMINISTRATIVE OFFICE
राजाजी सालै, चेन्नै - ६०० ००२.
Rajaji Salai, Chennai - 600 001.
Website : www.chennaiport.gov.in

Date :

No. MEE/HA2/MISC./2017/Dy.CME(W)

29.06.2018

Certificate No . 0854

VOCATIONAL INPLANT TRAINING CERTIFICATE

This is to certify that Shri/Selvi. M. JAYAKARAN Student of B.S. ABDUR RAHMAN CRESCENT INSTITUTE OF SCIENCE & TECHNOLOGY, VANDALUR, CHENNAI. has undergone INPLANT TRAINING as non-Stipendiary vocational trainee a period From 25.06.2018 to 29.06.2018 in the Electronic processing data Department / Electrical / Mechanical / Electronics division of Mechanical and Electrical Engineering Department in Chennai Port Trust.

During the period of training his / her attendance, work and conduct were found good.



C. Mahendiran
29/6/18
(C. MAHENDIRAN)
Principal (Basic Training)
for CHIEF MECHANICAL ENGINEER



सवारी डिब्बा कारखाना, चेन्नै - 600 038

रेल मंत्रालय की एक उत्पादन इकाई

INTEGRAL COACH FACTORY, CHENNAI - 600 038

A Production Unit Under Ministry of Railways

(AN ISO: 9001, ISO:14001 AND BS : 18001 CERTIFIED PRODUCTION UNIT)



Sl.No. : M/388/2018

Date : 19.06.2018



This is to certify that Mr./Ms. M. JAYAKARAN.....

Regn.No. 160021601064..... Course B.TECH.....

Branch MECHANICAL.....,..... II..... Year, Student of

B.S. Abdur Rahman Crescent Institute of Science and Technology,

has undergone Inplant Training from 11-06-2018..... to 18-06-2018.....

at Integral Coach Factory.



[Handwritten Signature]

Principal

Technical Training Centre

ICF, Chennai-38



ASHOK LEYLAND

Ennore, Chennai-57.

CERT No. HRD/T & D 086

Date: 10/01/17

CERTIFICATE

This is to Certify that Mr./Ms. A. B. MOHAMED ASLAM NOORANJ
Student of B. S. ABDUR RAHMAN UNIVERSITY was
offered In-plant training from 03/01/17 to 07/01/17 at
ASHOK LEYLAND LTD, Ennore, Chennai - 600 057.

DETAILS OF TRAINING ATTENDED

SL.No.	Department	Period of Exposure
1.	ENGINE ASSY	From: 03/01/17 To: 07/01/17
2.	GEAR BOX ASSY	
3.	CHASSIS ASSY	
4.	AXLE ASSY	
5.	ENGINE COMPONENTS	

Assessments

1. Attendance

No. of days available - 05 DAYS

No. of days attended - 05 DAYS

2. Punctuality - GOOD

3. Interest - GOOD

4. Conduct - GOOD

5. General Remarks - NIL

For ASHOK LEYLAND LTD.,

Name : K. BALAJI

Signature :

Designation : MANAGER [L&D]



ASHOK LEYLAND

Ennore, Chennai-57.

CERT No. HRD/T & D 086

Date: 10/01/17

CERTIFICATE

This is to Certify that Mr./Ms. A. B. MOHAMED ASLAM NOORANJ
Student of B. S. ABDUR RAHMAN UNIVERSITY was
offered In-plant training from 03/01/17 to 07/01/17 at
ASHOK LEYLAND LTD, Ennore, Chennai - 600 057.

DETAILS OF TRAINING ATTENDED

SL.No.	Department	Period of Exposure
1.	ENGINE ASSY	From : 03/01/17 To : 07/01/17
2.	GEAR BOX ASSY	
3.	CHASSIS ASSY	
4.	AXLE ASSY	
5.	ENGINE COMPONENTS	



For ASHOK LEYLAND LTD.,

Name : K. BALAJI

Signature : *K. Balaji*

Designation : MANAGER [LRD]

Assessments

1. Attendance

No. of days available - 05 DAYS

No. of days attended - 05 DAYS

2. Punctuality

- GOOD

3. Interest

- GOOD

4. Conduct

- GOOD

5. General Remarks

- NIL



CREDO SYSTEMZ
TRAINING & DEVELOPMENT

PRIMAVERA

ORACLE

Certificate of Excellence



This is to certify that

Syed Jaffer Sadiq I

Candidate ID : CRPRM5827

has successfully completed

Primavera P6 (Professional & Advanced) Training

course conducted during Mar 2017 - Apr 2017

Date: 09-04-2017

Authorised Signatory

2nd March, 2017

Dear N.T Roashan,

Subject: Offer Letter for Global Academic Internship Programme

Congratulations!

You have been selected for the Global Academic Internship Programme (GAIP) which is delivered with professors from two of the world's top 15 universities - National University of Singapore (NUS) and Nanyang Technological University (NTU) and industry partner - Hewlett Packard.

Global Academic Internship Programme (GAIP) is an opportunity for you to complete credit courses at world top 15 universities, work on industry projects and get global career insights. The entire programme is delivered in Singapore.

The key highlights of GAIP are:

1. Complete credit courses at world top-15 universities
2. Work on industry projects
3. Interact with world's top educators
4. Get global industry insights from senior leaders of top MNCs
5. Receive letter of evaluation from NTU/NUS faculty
6. Experience global industry trends through industry visits

Please find enclosed the programme and fee details.

Please note that your admission for GAIP will be confirmed only after payment of the programme fee (Rs 2,10,000) by **28th March, 2017**.

Best Wishes,
Aali Basant
Director
Corporate Gurukul

GLOBAL ACADEMIC INTERNSHIP PROGRAMME: OFFER LETTER

PROGRAMME MODULE

The following modules will be delivered as a part of the Global Academic Internship Programme.

Module Name	Domain Relevance
Big Data Analytics – certified by HP (Training, Projects and Assignments by NTU/NUS and HP)	1. Computer Science 2. Information Technology 3. Electronics and Telecommunication 4. Mechanical Engineering 5. Manufacturing

WHO SHOULD TAKE UP?

Graduates looking to start a career in:

- Big Data Analytics
- Data Management
- Data Science
- Business Intelligence

MODULE OBJECTIVES

After completing this course, you should be able to:

- Understand the importance of Big Data in today's business environment
- Understand key Big Data components currently used in Enterprises
- Understand, load, process and extract structured and unstructured data
- Simplify Big Data processing
- Understand fundamentals of the powerful and versatile HP IDOL platform and lays a firm foundation for the development of your IDOL knowledge

MODULE OVERVIEW

This course introduces the students to Big Data, how it contributes to industries worldwide, and shows application of skills in the field – giving students a full picture of the role of Big Data in today's technology and engineering applications.

The discussions will include real-life case studies, where organizations have leveraged Big Data for competitive advantage. This course provides an overview of many of the most popular Big Data solutions.

MODULE DETAILS

The details of the module are available to candidates who have accepted the offer letter.

PROGRAMME DURATION

Thirty (30) days in Singapore

PROGRAMME DATES

The programme will be conducted from 1st June, 2017 – 30th June, 2017 in Singapore

PROGRAMME VENUE

Nanyang Technological University (NTU), Singapore

FACULTY PROFILES

Faculty from two of the world's top 15 universities, National University of Singapore (NUS) and Nanyang Technological University (NTU) will train the participants on the above-mentioned modules. The faculty members will also assess and guide the participants on their project work along with industry experts.

LEARNING INTERVENTIONS

Pedagogy	Duration
Classroom/ Academic Intervention	60 hours
Corporate Interaction and Industry Visits	60 hours
Total number of hours 120 hours	

INDICATIVE PROGRAMME SCHEDULE

DAY	10:00 AM – 1:00 PM	3:00 PM – 6:00 PM	6:30 PM – 10:00 PM
MON - FRI (@NTU)	Training By NTU/NUS Faculty	Assignment, Project Work & Industry Visits	Self / Self Study
SAT (@NTU)	Industry Expert Interaction		
SUN (Free Day)	Field Visits/ Recreation		

CORPORATE GURUKUL

8 Eu Tong Sen Street, #14- 94, The Central, Singapore – 059818
603, Pentagon 1, Magarpatta City, Pune, India – 411028

Facebook/CorporateGurukul
www.corporategurukul.com

TO WHOMSOEVER IT MAY CONCERN

FESTO

This is to certify that Mr. Gangineni Sai Krishna, B.Tech Mechanical Engineering student from B S Abdur Rahman Crescent University, Institute of Science & Technology Vandalur, Chennai – 600 048 , he has undergoing the internship program from 16 /01/2018 to 23/02/2018 at Festo India Private Limited.

Dated

23/02/18

During his Internship training, he has interacted with Ms. Snehal VC, Engineer – Data Management, Mr. Govind Mayya, Manager – Production, Mr. Shanmugam Raja, Supervisor & Mr. Pradeep Venkatesh, Manager – Lean Management and he has worked on the below project,

Our Reference

1. Implementation of Kanban for Inputs Material of Robodrill Machine
2. Production Study of Piston Rods Cutting and Turning of Piston Rods.

18/07/AOS

Your Reference

Mr. Gangineni Sai Krishna has successfully completed the internship program and we have found him sincere, open to learnings and punctual during his Internship.

We wish Mr. Gangineni Sai Krishna all the very best in his future endeavours.

For Festo India Private Limited

Arun Sosle

Head – Manufacturing

Global Production Centre

Festo India Private Limited
(Formerly Festo Controls Private Limited)

Global Production Centre
225 & 226,
Bommasandra Industrial Area
Off Hosur Road
Bengaluru - 560 099, India

Tel : +91 80 2289 4100
Fax: +91 80 2783 2058
E-mail : ingpc.reception@festo.com
Website : www.festo.in

Registered Office
237B, Bommasandra Industrial Area
Hosur Road,
Bengaluru - 560 099, India
CIN: U29220KA1986PTC007449

TO WHOMSOEVER IT MAY CONCERN

FESTO

This is to certify that Mr. Venkata Sai Kumar Pulimi, B.Tech Mechanical Engineering student from B S Abdur Rahman Crescent University, Institute of Science & Technology Vandalur, Chennai – 600 048 , has undergone the internship program from 16 / 01/2018 to 23/02/2018 at Festo India Private Limited.

Dated

During his Internship training, he has interacted with Ms. Archana Hosamani, Senior Officer – Logistics, Mr. Sathish ES, Assistant Manager - Quality & Mr. Pradeep Venkatesh, Manager – Lean Management and he has worked on the below project,

23/02/18

Our Reference

1. Optimization of Material Supply in Plant – 3 Logistics.
2. Identification of Possible Safety Hazards in all the Production Fixtures.

18/02/AOS

Your Reference

Mr. Venkata Sai Kumar Pulimi has successfully completed the internship program and we have found him sincere, open to learnings and punctual during his Internship.

We wish Mr. Venkata Sai Kumar Pulimi all the very best in his future endeavours.

For Festo India Private Limited



Arun Sosle
Head – Manufacturing
Global Production Centre

Festo India Private Limited
(Formerly Festo Controls Private Limited)

Global Production Centre
225 & 226,
Bommasandra Industrial Area
Off Hosur Road
Bengaluru - 560 099, India

Tel : +91 80 2289 4100
Fax: +91 80 2783 2058
E-mail : ingpc.reception@festo.com
Website : www.festo.in

Registered Office
237B, Bommasandra Industrial Area
Hosur Road,
Bengaluru - 560 099, India
CIN: U29220KA1986PTC007449

**RENAULT NISSAN TECHNOLOGY &
BUSINESS CENTRE INDIA PRIVATE LIMITED**

Ascendas IT Park, Mahindra World City SEZ
No. TP 2/1, Natham Sub Post Office, Kancheepuram District, Tamil Nadu - 603004
CIN: U50401TN2007PTC064840, Tel: 91 44 67481000, Fax: 91 44 67481150

Ref: RNTBCI/HR/2017/0016

Date: 09-Nov-2017

TO WHOMSOEVER IT MAY CONCERN

This is to certify that **Mr. SHEIK MUHAMMED ZUBAIR (RRN:- 140021601196)**, doing B.Tech (Mechanical), B.S. ABDUR RAHMAN CRESCENT UNIVERSITY has completed the "Input Convergence for Renault & Nissan Diagnostics Businesses" from **09th Aug, 2017** to **09th Nov, 2017**.

During the tenure of his internship, the assignments given to him were completed on time and up to the expectation. His work was found to be **Good**.

We wish him all success in future endeavors.

Regards,

For Renault Nissan Technology and Business Centre India Pvt Ltd,

Sarmista Tripathy
Sarmista Tripathy
Human Resources

**RENAULT NISSAN
AUTOMOTIVE INDIA PRIVATE LIMITED**

Factory cum Registered Office: Plot No.1, SIPCOT Industrial Park, Oragadam
Mattur (Post), Sriperumbudur, Kanchipuram District - 602 105, Tamil Nadu.

Phone: +91 44 37199999 Fax: +91 44 37196803

CIN No: U34100TN2007PTC073002 PAN NO: AACDR7965B

TO WHOMEVER IT MAY CONCERN

Date: 10-05-2018

This is to certify that **Mr. ESWARAN SRIKRISHNA** studying B.Tech Mechanical Engineering in B.S.A Crescent Institute of Science and Technology has successfully completed his Internship project on "**Head Count Reduction In Trim & Chassis**" at **MSPO – Industrial Engineering Department** from **13th February 2018 to 10th May 2018** under the guidance of **Mr. Kumar A.**

We wish **Mr. Eswaran Srikrishna** all the best in his future endeavors.

For **Renault Nissan Automotive India Private Ltd**

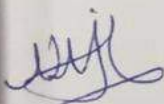

Nijil

Human Resources



BOSCH

Invented for life



RAJALAKSHMI
ENGINEERING COLLEGE

Certificate

Somesh.S

from B.S. Abdur Rahman University
has attended a training programme on Bosch Automotive Starter Motor & Alternator System
on 07.06.17
in Rajalakshmi Engineering College

and has successfully participated in this course, which included theory / working principle, testing and maintenance instruction of the product.

.....
Regional Trainer
Automotive Aftermarket
Bosch Limited

.....
Co-ordinator
Joint Certification Center
Rajalakshmi Engineering College

BONAFIDE CERTIFICATE

This is to certify that project on “ANALYSIS & IMPROVISATION OF NUT RUNNER MACHINE CAPABILITY USING STATISTICAL PROCESS CONTROL” was carried under our guidance at HYUNDAI MOTORS INDIA LIMITED (ENGINE #2) by “J.YABEZ RAJAIAH” from JAN 29th 2017 to MAR 28th 2018.



SIGNATURE

Mr. VENKAT.J

SENIOR EXECUTIVE

ENGINE QC

HYUNDAI MOTORS INDIA LTD.

SIGNATURE

Mr. SEKAR S

HOD

ENGINE QC

HYUNDAI MOTORS INDIA LTD.



Fax : 044/25361228
Phone : 25362201
Grams : PORTRUST
प्रशासनिक कार्यालय
ADMINISTRATIVE OFFICE
राजाजी सालै, चेन्नै-६०० ००१.
Rajaji Salai, Chennai - 600 001.
Website : www.chennaiport.gov.in

चेन्नै पोर्ट ट्रस्ट
CHENNAI PORT TRUST

Date : **16.07.2016**

No. MEE/TR4/244/2016/DY.CME(W)

Certificate No. 0666

VOCATIONAL INPLANT TRAINING CERTIFICATE

This is to certify that Shri / Selvi **SOMESH. S.** student of **B.S. ABDUR RAHMAN UNIVERSITY, CHENNAI.** has undergone **INPLANT TRAINING** as non-stipendiary vocational trainee for a period from **12.07.2016 to 16.07.2016** in the Electrical / Mechanical / Electronics division of Mechanical and Electrical Engineering Department in Chennai Port Trust.

During the period of training his / her attendance, work and conduct were found good.

C. Mahendiran
16/7/16

(C. MAHENDIRAN)
Principal (Basic Training Centre)
for CHIEF MECHANICAL ENGINEER

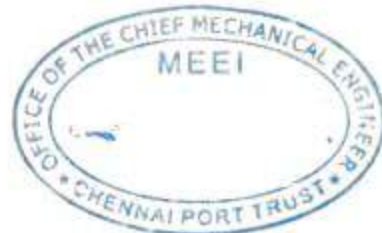

HR / 4/ TR4

Apr 04 2018

TO WHOMSOEVER IT MAY CONCERN

This is to certify that Mr.Somesh S a student of B.S. Abdur Rahman Crescent Institute of Science & Technology - Vandalur, has successfully completed his project training at our plant during the period from 05th Feb, 2018 to 04th Apr, 2018.

He has been a part of the project titled "Study And Implementation Of Led Optical Micrometer To Check The Diameter Of The Transmission Output Shaft " Department - Transmission 2" at Hyundai Motor India Limited.

During the training period, his level of commitment, involvement and attitude were found to be good.

We wish Mr.SOMESH S, all the best in his future endeavors.

For HYUNDAI MOTOR INDIA LIMITED



Mani Natchiappan

Learning & Development

B.S.ABDUR RAHMAN
CRESCENT UNIVERSITY

B.S. Abdur Rahman Crescent Institute of Science & Technology
(Estd. u/s 3 of the UGC Act, 1956)



www.bsauniv.ac.in

BONAFIDE CERTIFICATE

Certified that this project report **MANAGEMENT TOOL FOR RENAULT NISSAN AFTER SALES BUSINESS** is the bonafide work of **S. ZIEGEN BALG (RRN: 140021601232)** who carried out the project work under my supervision.

Certified further, that to the best of my knowledge the work reported herein does not form part of any other project report or dissertation on the basis of which a degree or award was conferred on an earlier occasion on this or any other candidate.

SIGNATURE

Mr. G. RAJESH
SUPERVISOR

Professor
Department of Mechanical Engineering
B. S. Abdur Rahman Crescent University
Vandalur, Chennai - 600 048.

SIGNATURE

Mr. YESHWANTHBABU
JOINT SUPERVISOR

Assistant Manager
GAS2, RNTBCI
Ascendas IT Park, MWC,
Chengalpet, Chennai - 603002.

SIGNATURE

Dr. S.RASOOL MOHIDEEN
HEAD OF THE DEPARTMENT
Professor & Head

Department of Mechanical Engineering
B. S. Abdur Rahman Crescent University
Vandalur, Chennai - 600 048.

27/12/2012

Dr. T. Jeyarajan

Ext. Examiner

TO WHOMSOEVER IT MAY CONCERN

This is to certify that Mr.Saurabh S a student of BS Abdur Rahman Crescent Institute of Science & Technology - Vandalur, has successfully completed his project training at our plant during the period from 26th Feb, 2018 to 25th Apr, 2018.

He has been a part of the project titled "Study And Implementation Of Led Optical Micrometer To Check The Diameter Of The Transmission Output Shaft " Department - Transmission #2" at Hyundai Motor India Limited.

During the training period, his level of commitment, involvement and attitude were found to be good.

We wish Mr.SAURABH S, all the best in his future endeavors.

For HYUNDAI MOTOR INDIA LIMITED



Mani Nachiappan Π

Learning & Development



BOSCH

Invented for life



RAJALAKSHMI
ENGINEERING COLLEGE

Certificate

Somesh.S

from B.S. Abdur Rahman University
has attended **a training programme on Bosch Engine Diagnostics System**
from **08.06.17 to 09.06.17**
in Rajalakshmi Engineering College

and has successfully participated in this course, which included theory / working principle, testing and maintenance instruction of the product.

.....
Regional Trainer
Automotive Aftermarket
Bosch Limited

.....
Co-ordinator
Joint Certification Center
Rajalakshmi Engineering College



BOSCH

Invented for life



RAJALAKSHMI
ENGINEERING COLLEGE

Certificate

Somesh.S

from B.S. Abdur Rahman University
has attended **a training programme on Bosch Inline & Distributor Type Fuel Injection System**
from **05.06.17 to 06.06.17**
in Rajalakshmi Engineering College

and has successfully participated in this course, which included theory / working principle, testing and maintenance instruction of the product.

.....
Regional Trainer
Automotive Aftermarket
Bosch Limited

.....
Co-ordinator
Joint Certification Center
Rajalakshmi Engineering College



HYUNDAI

July 22, 2016

HR / 07/ TR040

TO WHOMSOEVER IT MAY CONCERN

This is to certify that Mr. Somesh S a student of B.S.Abdur Rahman University has successfully completed his In-Plant training at our plant during the period from 18th July, 2016 to 22nd July, 2016.

During the training period, his level of commitment, involvement and attitude were found to be good.

We wish Mr. Somesh S, all the best in his future endeavors.

For HYUNDAI MOTOR INDIA LIMITED

Elamurugan P
Learning & Development



NEW THINKING. NEW POSSIBILITIES.

Hyundai Motor India Ltd.
Regd. Office & Factory : Plot No. H-1, SIPCOT Industrial Park,
Irrungattukottai, Sriperumbudur Taluk, Kancheepuram Dist.
Tamil Nadu-602 117, India. Tel : 044 - 47100000 Fax : 044 - 47100400
CIN : U29309TN1996PLC035377

TO WHOMSOEVER IT MAY CONCERN

FESTO

This is to certify that Mr. Riyaz Ahmed, B.Tech Mechanical Engineering student from B S Abdur Rahman Crescent University, Institute of Science & Technology Vandalur, Chennai – 600 048 , he has undergoing the internship program from 16 /01/2018 to 23/02/2018 at Festo India Private Limited.

Dated

23/02/18

During his Internship training, he has interacted with Ms. Snehal VC, Engineer – Data Management, Mr. Govind Mayya, Manager – Production, Mr. Shanmugam Raja, Supervisor & Mr. Pradeep Venkatesh, Manager – Lean Management and he has worked on the below project,

Our Reference

1. Implementation of Kanban for Inputs Material of Robodrill Machine
2. Production Study of Piston Rods Cutting and Turning of Piston Rods.

18/08/AOS

Your Reference

Mr. Riyaz Ahmed has successfully completed the internship program and we have found him sincere, open to learnings and punctual during his Internship.

We wish Mr. Riyaz Ahmed all the very best in his future endeavours.

For Festo India Private Limited

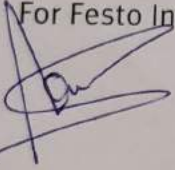
Arun Sosle
Head – Manufacturing
Global Production Centre

Festo India Private Limited
(Formerly Festo Controls Private Limited)

Global Production Centre
225 & 226,
Bommasandra Industrial Area
Off Hosur Road
Bengaluru - 560 099, India

Tel : +91 80 2289 4100
Fax: +91 80 2783 2058
E-mail : ingpc.reception@festo.com
Website : www.festo.in

Registered Office

237B, Bommasandra Industrial Area
Hosur Road,
Bengaluru - 560 099, India
CIN: U29220KA1986PTC007449

TO WHOMSOEVER IT MAY CONCERN

This is to certify that Mr. Praveen Kumar R, B.Tech Mechanical Engineering student from B S Abdur Rahman Crescent University, Institute of Science & Technology Vandalur, Chennai – 600 048 , he has undergoing the internship program from 16 / 01/2018 to 23/02/2018 at Festo India Private Limited.

Dated

23/02/18

During his Internship training, he has interacted with Mr. Abhilash Nagaraju, Assistant Manager – Logistics, Ms. Sreelaxmi Katte, Team Lead & Mr. Pradeep Venkatesh, Manager – Lean Management and he has worked on the below project,

Our Reference

18/05/AOS

1. Implementation of Kanban for Common Parts in Cylinder Assembly Lines.
2. Production Study of Three Cylinder Assembly Lines.

Your Reference

Mr. Praveen Kumar R has successfully completed the internship program and we have found him sincere, open to learnings and punctual during his Internship.

We wish Mr. Praveen Kumar R all the very best in his future endeavours.

For Festo India Private Limited

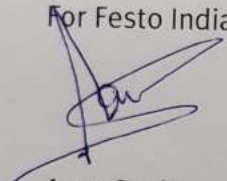

Arun Sosle

Head – Manufacturing

Global Production Centre

Festo India Private Limited
(Formerly Festo Controls Private Limited)

Global Production Centre
225 & 226,
Bommasandra Industrial Area
Off Hosur Road
Bengaluru - 560 099, India

Tel : +91 80 2289 4100
Fax: +91 80 2783 2058
E-mail : ingpc.reception@festo.com
Website : www.festo.in

Registered Office
237B, Bommasandra Industrial Area
Hosur Road,
Bengaluru - 560 099, India
CIN: U29220KA1986PTC007449

TO WHOMSOEVER IT MAY CONCERN

FESTO

This is to certify that Mr. Imran Shaik, B.Tech Mechanical Engineering student from B S Abdur Rahman Crescent University, Institute of Science & Technology Vandalur, Chennai – 600 048 , he has undergoing the internship program from 16 / 01/2018 to 23/02/2018 at Festo India Private Limited.

Dated

During his Internship training, he has interacted with Mr. Abhilash Nagaraju, Assistant Manager – Logistics, Ms. Sreelaxmi Katte, Team Lead & Mr. Pradeep Venkatesh, Manager – Lean Management and he has worked on the below project,

23/02/18

1. Implementation of Kanban for Common Parts in Cylinder Assembly Lines.
2. Production Study of Three Cylinder Assembly Lines.

Our Reference

18/06/AOS

Mr. Imran Shaik has successfully completed the internship program and we have found him sincere, open to learnings and punctual during his Internship.

Your Reference

We wish Mr. Imran Shaik all the very best in his future endeavours.

For Festo India Private Limited

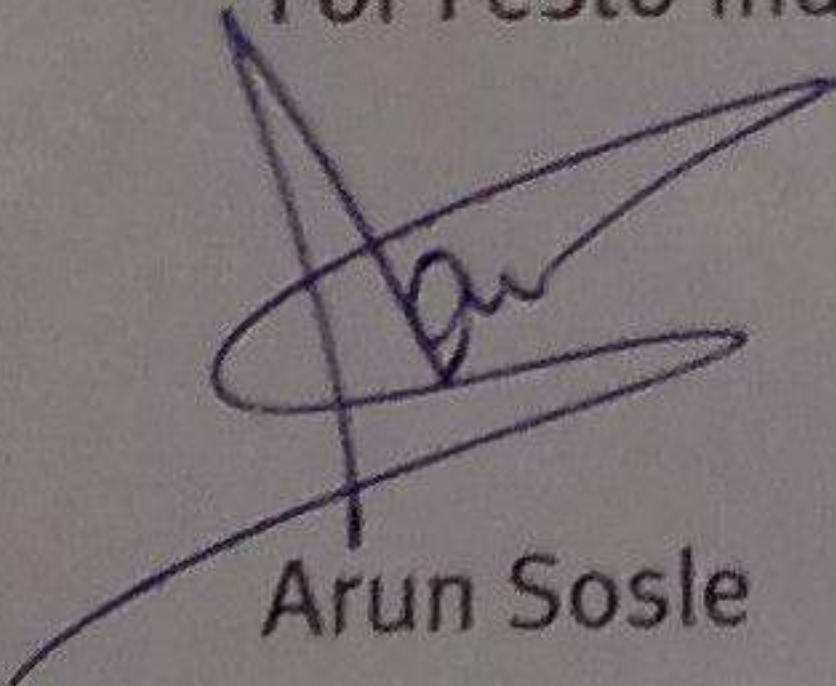
Arun Sosle

Head – Manufacturing

Global Production Centre

Festo India Private Limited
(Formerly Festo Controls Private Limited)

Global Production Centre
225 & 226,
Bommasandra Industrial Area
Off Hosur Road
Bengaluru - 560 099, India

Tel : +91 80 2289 4100
Fax : +91 80 2783 2058
E-mail : ingpr_reception@festo.com
Website : www.festo.in

Registered Office

237B, Bommasandra Industrial Area
Hosur Road,
Bengaluru - 560 099, India
CIN: U29220KA1986PTC007449

HR / 5/ TR1

May 2 2018

TO WHOMSOEVER IT MAY CONCERN

This is to certify that Mr.Paveen R a student of Crescent Institute of Science & Technology - Vandalur, has successfully completed his project training at our plant during the period from 05th Mar, 2018 to 02nd May, 2018(30 days).

He has been a part of the project titled "Down Time Reduction " Department - P/Car -1 Maintenance" at Hyundai Motor India Limited.

During the training period, his level of commitment, involvement and attitude were found to be good.

We wish Mr.PAVEEN R, all the best in his future endeavors.

For HYUNDAI MOTOR INDIA LIMITED

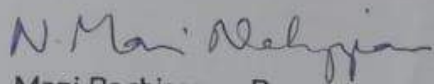

Mani Pachiappan P

Learning & Development

Feb. 09, 2018

To
The Registrar,
Crescent Institute of Science & Technology,
Chennai-600048.

Dear Sir/Madam,

Sub: Permission to Mr.Nouman Shareef .F.M to undergo Training-reg.

Ref : Your Bonafide Certificate No.C3:2018 Dt.08.02.2018

We are pleased in permitting your final year B.Tech student **Mr. Nouman Shareef F.M** having RRN:140021601155 as Project Trainee to undergo **Internship Training** in our organization, **Maraica Industries** with the guidance of Mr.J.M.Mohamed Imran, Manager-Projects whose mail ID and phone no. are imran@maraica.com. & 9500048444 respectively.

The duration of the Training will be for 2 months from Feb.09, 2018.

Hope, he will gain practical exposure in our organization.

Thanking you.

Yours faithfully,

For MARAICA INDUSTRIES

Manager-HR





MARAICA INDUSTRIES
Masters in Metal Press Components

Factory : # 3/621 (3/239), East Coast Road,
Palavakkam, Chennai - 600 041.
Ph/Tele fax : 2492 3629, 2498 7884
e-mail : info@maraica.com
Website : www.maraica.com

Feb. 02, 2018

To
The Registrar,
Crescent Institute of Science & Technology,
Chennai-600048.

Dear Sir/Madam,
Sub: Permission to Mr.R.S.Nithin Kumar to undergo Training-reg.
Ref : Your Bonafide Certificate No.3:C:2018 Dt.22.01.2018

We are pleased in permitting your final year B.Tech student **Mr. R.S.Nithin Kumar** as Project Trainee to undergo **Internship Training** in our organization, **Maraica Industries** with the guidance of Mr.J.M.Mohamed Imran, Manager-Projects whose mail ID and phone no. are imran@maraica.com. & 9500048444 respectively.

The duration of the Training will be for 2 months from Feb.02, 2018.

Hope, he will gain practical exposure in our organization.

Thanking you.

Yours faithfully,

For **MARAICA INDUSTRIES**

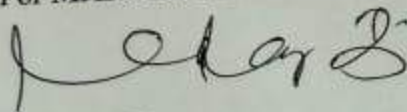
Manager-HR





MARAICA INDUSTRIES
Masters in Metal Press Components

Factory : # 3/621 (3/239), East Coast Road,
Palavakkam, Chennai - 600 041.
Ph/Tele fax : 2492 3629, 2498 7884
e-mail : info@maraica.com
Website : www.maraica.com

Feb. 09, 2018

To
The Registrar,
Crescent Institute of Science & Technology,
Chennai-600048.

Dear Sir/Madam,

Sub: Permission to Mr.Niyamathullah.S to undergo Training-reg.

Ref : Your Bonafide Certificate No.C3:2018 Dt.08.02.2018

We are pleased in permitting your final year B.Tech student **Mr. Niyamathullah.S** having RRN:140021601154 as Project Trainee to undergo **Internship Training** in our organization, **Maraica Industries** with the guidance of Mr.J.M.Mohamed Imran, Manager-Projects whose mail ID and phone no. are imran@maraica.com. & 9500048444 respectively.

The duration of the Training will be for 2 months from Feb.09, 2018.

Hope, he will gain practical exposure in our organization.

Thanking you.

Yours faithfully,

For **MARAICA INDUSTRIES**

Manager-HR



Suchikha Enterprises

An ISO 9001-2008 Company

Manufactures of Corrugated Boxes and Printed Cartons

Feb 05,2018

To:

The Register,

Crescent Institute of Science and Technology,

Chennai-600048.

Dear Sir/Madam,

Sub: Permission to Mr. Prakash Raj to undergo Training-reg.

Ref: Your bonafide certificate No: C3:2018 are dated in 05.02.2018.

We are Pleased in permitting your final year B.TECH student **Mr.V.Prakash Raj** as Project Trainee to undergo internship training in our Organization, **Suchika Enterprises**

With the guidance of Mr. A. Jothi Basu, Manager-Projects whose mail ID and phone no are ajothibasus87@gmail.com and 9042419345 respectively.

The Duration of the Training will be two month from Feb 05,2018.

Hope, He will gain practical exposure from our organization.

Thanking you.

Yours faithfully,

For, **SUCHIKA ENTERPRISES**

Manager-HR

A. Jothi
05/02/2018



EP 16 SIDCO Industrial Estate Maraimalai Nagar - 603209.

Tel : 044-47400110 Cell : 98417 42207, 99520 33899

E-mail : suchikha@hotmail.com



ISO 9001 : 2008 Reg.No.497907

**RENAULT NISSAN TECHNOLOGY &
BUSINESS CENTRE INDIA PRIVATE LIMITED**

Ascendas IT Park, Mahindra World City SEZ
No. TP 2/1, Natham Sub Post Office, Kancheepuram District, Tamil Nadu - 603004
CIN: U50401TN2007PTC064840, Tel: 91 44 67481000, Fax: 91 44 67481150

Ref: RNTBCI/HR/2017/0015

Date: 24-Nov-2017

TO WHOMSOEVER IT MAY CONCERN

This is to certify that **Mr. Mohammad Affan A R (140021601125)**, doing B.Tech (Mechanical Engineering), BS Abdur Rahman University has completed the "*Study of Reduction of structure borne noise of a powertrain through numerical simulation*" from 9th Aug, 2017 to 24th Nov 2017.

During the tenure of his Internship, the assignments given to him were completed on time and up to the expectation. His work was found to be **Very Good**.

We wish him all success in future endeavors.

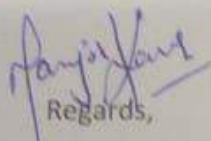
Regards,

Manjot Kaur

Human Resources

For Renault Nissan Technology and Business Centre India Pvt Ltd,

HR / 5/ TR2

May 2 2018

TO WHOMSOEVER IT MAY CONCERN

This is to certify that Mr. Prasath SSP a student of Crescent Institute of Science & Technology – Vandalur, has successfully completed his project training at our plant during the period from 05th Mar, 2018 to 02nd May, 2018 (31 days).

He has been a part of the project titled "Down Time Reduction " Department - P/Car -1 Maintenance" at Hyundai Motor India Limited.

During the training period, his level of commitment, involvement and attitude were found to be good.

We wish Mr. PRASATH SSP, all the best in his future endeavors.

For HYUNDAI MOTOR INDIA LIMITED

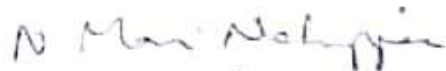

Mani Natchiappan

Learning & Development



Valeo Friction Materials India Private Limited
Regd. Office & Factory:
No.16A Sengundram Industrial Area,
Melrosapuram, Via.Singaperumal Koil,
Kancheepuram District - 603 204
Tamil Nadu, India
Phone: +91-44-4741 3450
Fax: +91-44-4741 3480
CIN - U29309TN1997PTC038508

Dated 30-04-2018

TO WHOMSOEVER IT MAY CONCERN

This is to certify that **Mr. L.R.Prasanna** (RR No: **140021601160**) of BSA Crescent Institute of Science & Technology – Vandalur has done his Internship & Final project with us in the title **“Design and Maintain The Humidity In Clutch Face Manufacturing Industry Through Dehumidification Technique”** under the guidance of Mr. M.Mallikarjun, Head – VPS-Methods from **07-02-2018 to 30-04-2018**.

We wish him all success for his future.

For Valeo Friction Materials India Private Limited.

J.Sathiyaseelan

Head – HR

M.Maliikarjun

Head – VPS-Methods



Valeo Friction Materials India Private Limited
Regd. Office & Factory:
No.16A Sengundram Industrial Area,
Melrosapuram, Via.Singaperumal Koil,
Kancheepuram District - 603 204
Tamil Nadu, India
Phone: +91-44-4741 3450
Fax: +91-44-4741 3480
CIN - U29309TN1997PTC038508

Dated 30-04-2018

TO WHOMSOEVER IT MAY CONCERN

This is to certify that **Mr. K.Ravi Kumar (RR No: 140021601169)** of BSA Cresnet Institute of Science & Technology – Vandalur has done his Internship & Final project with us in the title **“Design and Maintain The Humidity In Clutch Face Manufacturing Industry Through Dehumidification Technique”** under the guidance of Mr. M.Mallikarjun, Head – VPS-Methods from **07-02-2018 to 30-04-2018**.

We wish him all success for his future.

For Valeo Friction Materials India Private Limited.

J.Sathiyaseelan

Head – HR

M.Maliikarjun

Head – VPS-Methods

DEPARTMENT OF ELECTRONICS AND INSTRUMENTATION ENGINEERING

TAMILNADU GENERATION AND DISTRIBUTION CORPORATION LIMITED

From
Er.U.Vallammai,M.Tech.,
 Superintending Engineer/Operation,
 North Chennai Thermal Power Station
 Chennai - 600 120

To
 The Principal,
 Crescent Institute of Science & tech,
 GST Road,Vandalur,
 Chennai -600 048.

Lr.No.SE/OPN/NCTPS-I/EE/TRG & RES/F - PW/D. 23/19,DT: 21-01-2019

Sir,

Sub: NCTPS-Opn.-Training Dn.- Project Work -Permission Granted -Reg.
 Ref: EIE/B.Tech Project/2018-19/1, dt:21/01/2019.

With reference to your Lr.dt: 21/01/2019, the following is informed in respect of permission to carry out the Project Work at NCTPS-I for the student of your institution.

- i) An amount of **Rs.1180/- (including GST @ 18%) per student** has to be paid individually for carrying out project work in the mode of "**Demand Draft**" in favour of "**TNEB Collection Account**" payable at **Chennai (or) Cash paid at NCTPS-I cash section** and it should be submitted to the reporting Officer At the time of commencement of Project work without fail.
- ii) An undertaking as per the **Annexure** enclosed has to be furnished by each student of your Institution.
- iii) **Sons/Daughters** of the employees of TNEB are exempted from the payment of above said fee.
- iv) Students undergoing project work have to submit two copies of **report** after completion of their project work.
- v) Students who have completed **5th Semester** studies and above shall alone be permitted to undergo Project work.
- vi) The period of project work shall be three months from the date of commencement.
- vii) Students doing project work shall arrange their Guide in the power station by themselves for their project work.
- viii) Request seeking withdrawal of permission granted / alteration of the dates granted for Project work, shall not be entertained under any circumstances.

Subject to agreeing the above said conditions, Permission will be granted for the following Students to carry out the Project work at North Chennai Thermal Power Station, Chennai - 120 as mentioned below:

Sl. No	Name of the Student	Branch & College	Period of Project work	Officer to whom to report
1	J.Mohamed Ashik	Final- year BE(EIE) Crescent Institute of Science & tech, GST Road,Vandalur, Chennai -600 048.	From 28-01-18 To 26-04-18	Executive Engineer, Training & Reserve, NCTPS, Chennai- 120.
2	S.Thahiranazreen			
3	V.Varshan			
4	M.Mohamad Raiyan			

Yours faithfully,

U. Vallammai
SUPERINTENDING ENGINEER,
OPERATION,
NCTPS/CHENNAI-120.

Copy to the Superintending Engineer / P&A/NCTPS-I
 Copy to the Executive Engineer / CAD/NCTPS-I

E.T.N

MTL Instruments Pvt. Limited

No.3, Old Mahabalipuram Road
Sholinganallur, Chennai-600 119
Tel : +91 (0)44 4450 1500/1551
Fax : +91 (0)44 44501553
CIN: U33112TN1989PTC018507
GST 33AAACM2555R126

27th May 2019

To Whomsoever It May Concern

We are pleased to inform that Mr. J Mohamed Syed Ali (RRN-150061601012), undergoing B. Tech (Instrumentation & Instrumentation Engineering) at B S Abdur Rahman Institute of Science and Technology, Vandalore, Chennai has successfully completed his 4 months Internship program.

During the period from January to April 2019, he has had his orientation in the various functions of the organization, beginning with Health & Safety, Engineering Test Labs, also completed his on-Plant training titled Oxygen analyzer using electrochemical cell in our organization.

We have found J Mohamed Syed Ali to be committed, disciplined and focused in his learning and possessing good inter-personal skills.

We wish him all the very best in his future endeavors.

MTL Instruments Private Limited;

[Signature]
Regional Director
HR - HR

House-Hinds
E.T.N



Regd. Office: MTL Instruments Private Limited, No.3, Old Mahabalipuram Road, Sholinganallur, Chennai-600 119.

ABSTRACT

To Whomsoever It May Concern

We are pleased to inform that Mr. R S Shrikanth (RRN-150061601023), undergoing B. Tech (Instrumentation & Instrumentation Engineering) at B S Abdur Rahman Institute of Science and Technology, Vandalore, Chennai has successfully completed his 4 months Internship program. During the period from January to April 2019, he has had his orientation in the various functions of the organization, beginning with Health & Safety, Engineering Test Labs, also completed his final assignment titled Oxygen analyzer using electrochemical cell in our organization.

We have found R S Shrikanth to be committed, disciplined and focused in his learning and possessing good inter-personal skills. We wish him all the very best in his future endeavors.

MTL Instruments Private Limited;

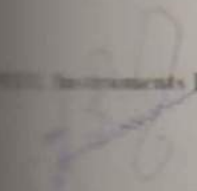
Manager, Chennai
Date: 15/05/2019



2019

Date: 09 May

PROJECT COMPLETION CERTIFICATE

This is to certify that below students from Crescent Institute of Science & Technology (Electronics and Instrumentation Engineering department) has done their project from February 2019 to April 2019 and found the result satisfactory.

S.No	Name of the Student	Roll Number
1	Ashif Rahman M	150061601002
2	Ashika S	150061601003
3	Sasikala C	150061601033

For DENVIK TECHNOLOGY PVT LTD



Authorized Signatory

www.denvik.in**DENVIK TECHNOLOGY PRIVATE LIMITED**

Plot No. 45, Second Street, Raju Nagar, Mettukuppam,
Okkiyam Thoraipakkam, Chennai - 600 097.
Phone : 044 - 4383 5320



CERTIFICATE

This is to certify that the following Final year B.E, (Electronics & Instrumentation Engineering) students of B.S.Abdur Rahman Crescent Institute of Science & Technology, Vandalur, Chennai. have done the Project work in Valuthur Gas Turbine Power Station, TANGEDCO, Ramanathapuram.

- 1) Selvan. S.Nazeer Ahamed,
- 2) Selvan. A.Saravana Prashanth,

The Title of the Project is “DESIGN OF CONTROLLER FOR SPEED CONTROL OF STEAM TURBINE” The External Guide for the above project is Er.E.Perumal, Assistant Executive Engineer / Electrical /C & I/Ph I /VGTPS /Ramanathapuram.

The period of the Project is 07.02.2019 to 08.03.2019.

Date:
Office Seal:



SUPERINTENDING ENGINEER,
VGTPS/RAMNAD.

DEPARTMENT OF ELECTRONICS AND INSTRUMENTATION - INTERNSHIP

To: <ashwinth.j1998@gmail.com>, <ashiqashiq78@gmail.com>, <shirsabesan1198@gmail.com>, <vytlapavankumar98@gmail.com>

Cc: <veda@niot.res.in>

Dear Student,

With reference to your application submitted for Student Internship Training, the competent authority has accorded approval.

Student Internship Training:

Mr. J. Ashwinth, Mr. N. Mohammed Ashiq, Mr. V. Pavan Kumar, Mr. T. Shir Sabesan, B.Tech, III Year, Crescent Institute of Science & Technology, Chennai under Ms. Nidhi Varshney, Scientist - D, Deep Sea Technologies from 19.06.2019 to 19.07.2019 .

This is for your kind information and records.

(Note: Student is directed to meet HRD Secretary along with a copy of this mail while joining the training)

Regards,

S.G.Divyaa

HRD SECRETARY

National Institute of Ocean Technology,

MOES, Govt. of [India](#).

[Velachery-Tambaram Road, Pallikaranai, Chennai, India-600 100.](#)

Phone: +91-44-6678 3572

If you are not the intended recipient and if you have received this email in error please notify the system manager at sysadmin@niot.res.in and delete this e-mail from your system.



April 5, 2018

No.A/HR/507/1047/2018

The Professor & Head
Department of Aerospace Engineering
Crescent Institute of Science & Technology
Vandalur, Chennai 600 048

Sir,

Sub : Permission for Project Work

Reference is made to your letter No. 05/HoD(Aero)/2018 dated 11.01.2018 on the subject matter.

2. We are pleased to inform you that the following students who are studying B.Tech Aeronautical in your College have been permitted to carry out the Project Work in Aircraft Division from 01.06.2018 to 31.07.2018 on 'No Pay No Fee' basis. Please note that the training is to be completed by the students within this period and **no extension** thereafter shall be considered by us.

SL NO	NAME	USN NO
1	Abdul Rahim K	150091601001
2	Harichandana V	150091601008
3	Ayisha Zuleikha K	150091601005
4	Mohammed Sha Nawzdeen	150091601012
5	Savitha A	150091601015
6	Mohammed Al Salama	150091601011

3. Mr. N Harish, Mgr (Sheet Metal) or any other Officer assigned by him will co-ordinate the activities pertaining to the Project. The details of the project and the subject/timings may be finalized in consultation with the co-ordinator.

- The Student should not use any classified / Sensitive information that may come to his knowledge during the Internship in his report or for any other purpose.
- The students should get the Project work vetted by the guide before submitting to the College.
- The students will have to make his own arrangements for stay and transportation to the factory and back.
- The Company will not take any responsibility for any accident / incidents that may occur inside or outside the factory premises.
- The Students are required to bring Police clearance from the Commissioner of Police / Superintendent of Police as per proforma enclosed along with 2 Stamp size photos and contact Dy. Gen. Manager (Security) for issuance of Security Pass.
- Electronic Items such as Camera, Mobile Phones, Digital Dairy and Calculator etc. are not permitted into the Factory premises.**
- If canteen service is required the student may avail the same by paying the prescribed amount.
- Duly filled **Indemnity Bond in an Non-Judicial Stamp for Rs.50/- individually to be** submitted to HR Department on the day of reporting.
- Students has to strictly follow the prescribed **Dress Code** i.e (Gents- Formal Trousers and Shirts for Ladies Salwar Kameez with Dupatta only).
- Project Work/Internship Training is provided to India: Nationals only.
- The reporting time on the first day is 12:30pm .

Yours faithfully,
for HINDUSTAN AERONAUTICS LTD,

(B AROCKIA JOTHI)
SENIOR MANAGER (HR)

5/4/18

Encl : As stated.

ನೋಂದಾಯಿತ ಕಚೇರಿ : ೧೫/೧, ಕಬ್ಬನ್ ರಸ್ತೆ, ಬೆಂಗಳೂರು-೫೬೦೦೦೧, ಭಾರತ

www.hal-india.com

14th February, 2019

TO WHOM IT MAY CONCERN

This is to certify that Mr. SANGEETH KUMAR.S a student of Crescent Institute of Science and Technology, Chennai, Tamil Nadu, India has successfully completed the internship program from 5th January 2019 to 25th January 2019 at Aviocian Technologies Private Limited, New Delhi. He has satisfactorily worked on the project "Design and Development of Hybrid UAV" During the internship period he was found to be punctual, hardworking and creative in his approach.

We wish him all the very best in his future endeavors.

Yours Sincerely,

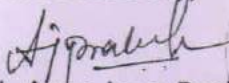

A.J. Arun Jeya Prakash

Co-Founder & CEO

Aviocian Technologies Pvt. Ltd.

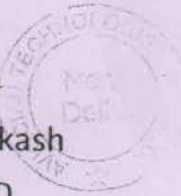

14th February, 2019

TO WHOM IT MAY CONCERN

This is to certify that Mr. NANDA KUMAR.G a student of Crescent Institute of Science and Technology, Chennai, Tamil Nadu, India has successfully completed the internship program from 5th January 2019 to 25th January 2019 at Aviocian Technologies Private Limited, New Delhi. He has satisfactorily worked on the project "Design and Development of Hybrid UAV" During the internship period he was found to be punctual, hardworking and creative in his approach.

We wish him all the very best in his future endeavors.

Yours Sincerely,

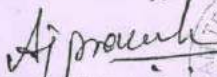

A.J. Arun Jeya Prakash

Co-Founder & CEO

Aviocian Technologies Pvt. Ltd.





AVIOCIAN TECHNOLOGIES PRIVATE LIMITED

125/13 Amrit Puri East of Kailash, New Delhi

Pin Code- 110065

Phone No.: +91-8810538822

Email: info@aviociantech.com, aviociantech@gmail.com

Website: www.aviociantech.com

14th February, 2019

TO WHOM IT MAY CONCERN

This is to certify that Mr. NAGOOR MEERAN.A a student of Crescent Institute of Science and Technology, Chennai, Tamil Nadu, India has successfully completed the internship program from 5th January 2019 to 25th January 2019 at Aviocian Technologies Private Limited, New Delhi. He has satisfactorily worked on the project "Design and Development of Hybrid UAV" During the internship period he was found to be punctual, hardworking and creative in his approach.

We wish him all the very best in his future endeavors.

Yours Sincerely,

A handwritten signature in black ink, appearing to read 'Arun Jeya Prakash'.

A.J. Arun Jeya Prakash

Co-Founder & CEO

Aviocian Technologies Pvt. Ltd.





AVIOCIAN TECHNOLOGIES PRIVATE LIMITED

125/13 Amrit Puri East of Kailash, New Delhi

Pin Code- 110065

Phone No.: +91-8810538822

Email: info@aviociantech.com, aviociantech@gmail.com

Website: www.aviociantech.com

14th February, 2019

TO WHOM IT MAY CONCERN

This is to certify that Mr. MOHAMED AFRIDH.A a student of Crescent Institute of Science and Technology, Chennai, Tamil Nadu, India has successfully completed the internship program from 5th January 2019 to 25th January 2019 at Aviocian Technologies Private Limited, New Delhi. He has satisfactorily worked on the project "Design and Development of Hybrid UAV" During the internship period he was found to be punctual, hardworking and creative in his approach.

We wish him all the very best in his future endeavors.

Yours Sincerely,

A handwritten signature in black ink, appearing to read "A.J. Arun Jeya Prakash".

A.J. Arun Jeya Prakash

Co-Founder & CEO

Aviocian Technologies Pvt. Ltd.



UNIVERSITY *of* MISSOURI

INSTITUTE FOR CLINICAL AND TRANSLATIONAL SCIENCE

April 22, 2019

Pradeep Parthasarathy
Orikkai, Kanchipuram
Tamil nadu

Dear Pradeep:

I am pleased to inform you that you have been selected and accepted as a Visiting Student Researcher with the MU Institute for Clinical and Translational Science (MU-iCATS) from May 29, 2019 – July 26, 2019. Our faculty is looking forward to the opportunity to provide exceptional mentoring for you during the Summer Research Project, and you will have the opportunity to work with an outstanding research team in an area related to your academic interests. I believe you will find our campus to be an excellent environment in which to experience a summer research project, and the MU-iCATS office will do our best to ensure an outstanding experience for you.

As an MU-iCATS Visiting Student Researcher, you will receive a stipend of \$1,500, on-campus room and board, and one hour of research credit that you may transfer back to your college. The total value of this award is \$ \$6,700. Your participation will be coordinated by the Office of Undergraduate Research (OUGR). In addition to your research experience, the program will also sponsor weekly workshops and seminars, brown bag lunches, social activities, and a poster session scheduled for July 25, 2019, to mark the end of a successful and productive summer. Participants will travel to Columbia on May 25-26, with an informal dinner on the evening of May 28. The orientation session will begin at 8:15am on Wednesday morning, May 29, followed by a team challenge 9am – 12pm (run by MU's Venture Out). There will be a break for lunch, more orientation meetings 2pm – 3pm, then your mentor will escort you to your lab instruction and introductions. Visiting students should plan to wrap things up in their laboratories on Friday, July 26; the program will be complete on Saturday, July 27, and you will be able to travel home anytime on Saturday.

OUGR will be taking care of your housing and registration arrangements. **Please complete the online Visiting Student Application, a copy of your passport and Visa (scanned copies via email), and complete the online acceptance form, within 2 weeks of receiving this letter** to confirm your participation in the program so that OUGR can begin processing the paperwork for your residence hall room and student identification number. The MU International Center will assist you with the necessary documentation and information to apply for the J-1 Exchange Student Visa at the U.S. Consulate having jurisdiction in your place of residence. Once you arrive on campus, you will also be required to check-in with the International Center in order to validate your J-1 student status.



Debbie Taylor will be contacting you by phone or e-mail soon to confirm the airline reservations. You will receive an additional memo before the program begins with a few final details.

If you need any additional information or have any questions, please contact Debbie Taylor (573-884-0042) or taylor@health.missouri.edu; we will do all we can to provide assistance and to welcome you to the University of Missouri School of Medicine. Congratulations on the distinction of being a Visiting Student Researcher of MU-iCATS.

Sincerely,

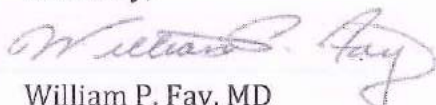
A handwritten signature in cursive script that reads "William P. Fay". The signature is written in dark ink and is positioned to the left of the typed name.

William P. Fay, MD
Director

UNIVERSITY *of* MISSOURI

INSTITUTE FOR CLINICAL AND TRANSLATIONAL SCIENCE

April 22, 2019

Krithika Velmurugan
#16/B, R. S. Amudham Apartments, Perumal
Nagar, Mogappair East
Chennai 600037

Dear Krithika:

I am pleased to inform you that you have been selected and accepted as a Visiting Student Researcher with the MU Institute for Clinical and Translational Science (MU-iCATS) from May 29, 2019 – July 26, 2019. Our faculty is looking forward to the opportunity to provide exceptional mentoring for you during the Summer Research Project, and you will have the opportunity to work with an outstanding research team in an area related to your academic interests. I believe you will find our campus to be an excellent environment in which to experience a summer research project, and the MU-iCATS office will do our best to ensure an outstanding experience for you.

As an MU-iCATS Visiting Student Researcher, you will receive a stipend of \$1,500, on-campus room and board, and one hour of research credit that you may transfer back to your college. The total value of this award is \$ 6,700. Your participation will be coordinated by the Office of Undergraduate Research (OUGR). In addition to your research experience, the program will also sponsor weekly workshops and seminars, brown bag lunches, social activities, and a poster session scheduled for July 25, 2019, to mark the end of a successful and productive summer. Participants will travel to Columbia on May 25-26, with an informal dinner on the evening of May 28. The orientation session will begin at 8:15am on Wednesday morning, May 29, followed by a team challenge 9am – 12pm (run by MU's Venture Out). There will be a break for lunch, more orientation meetings 2pm – 3pm, then your mentor will escort you to your lab instruction and introductions. Visiting students should plan to wrap things up in their laboratories on Friday, July 26; the program will be complete on Saturday, July 27, and you will be able to travel home anytime on Saturday.

OUGR will be taking care of your housing and registration arrangements. **Please complete the online Visiting Student Application, a copy of your passport and Visa (scanned copies via email), and complete the online acceptance form, within 2 weeks of receiving this letter** to confirm your participation in the program so that OUGR can begin processing the paperwork for your residence hall room and student identification number. The MU International Center will assist you with the necessary documentation and information to apply for the J-1 Exchange Student Visa at the U.S. Consulate having jurisdiction in your place of residence. Once you arrive on campus, you will also be required to check-in with the International Center in order to validate your J-1 student status.



Debbie Taylor will be contacting you by phone or e-mail soon to confirm the airline reservations. You will receive an additional memo before the program begins with a few final details.

If you need any additional information or have any questions, please contact Debbie Taylor (573-884-0042) or taylor@health.missouri.edu; we will do all we can to provide assistance and to welcome you to the University of Missouri School of Medicine. Congratulations on the distinction of being a Visiting Student Researcher of MU-iCATS.

Sincerely,

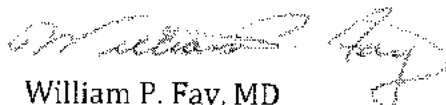
A handwritten signature in cursive script, appearing to read "William P. Fay".

William P. Fay, MD
Director

REF: ORIANA/INT/130/2018-2019

08th January 2019

Mr. J. Abdul Mohammed,

Reg.No. 160282602002,

MCA – B.S. Abdul Rahman Crescent Institute of Science and Technology

Chennai.

Subject: Internship Offer

Dear Abdul Mohammed,

In reference to your application we would like to congratulate you on being selected for internship with us. Your internship is scheduled to start effective **January 2019** and will end on approximately **May 2019**. All of us at **Oriana Information Technologies LLP.**, are excited that you will be joining our team!

During your internship, you may come across confidential business information. By accepting this internship, you acknowledge that you must adhere to the company's confidentiality policy. In addition, upon conclusion of your internship, you must return all company-owned property, equipment, documents and other informations.

As such, your internship will include training/orientation and focus primarily on learning and developing new project ideas & implementation and gaining a deeper understanding of concepts through hands-on application of the knowledge whereas the outstanding performance would be recognized & appraised with stipend.

The project details and technical platform will be shared with you on or before commencement of internship.

For **Oriana Information Technologies LLP.**,

Abhinav

Authorized Signature

+91 44 66255663

info@orianainfotech.com

www.orianainfotech.com

Oriana Information Technologies LLP.

51, First floor, Tower B, TFK Meadows, Sholinganallur, Chennai – 600 119.



BNP PARIBAS

The bank
for a changing
world

Strictly Private & Confidential

Mr Ahamed Moitheen Fayaz Thajudeen
No: 47/1, Kalathiyappa street (Ground floor),
Choolai, Chennai.
Tamilnadu - 600112.

Dear **Ahamed Moitheen Fayaz,**

With reference to your application and the recent discussions you have had with us, we are pleased to offer you 5 Months internship with BNP Paribas India Solutions Pvt. Ltd ("Company") at our **Chennai** office in **Testing Center of Excellence Department** for the period **January 02, 2019 to May 31, 2019** as part of your completion of studies. Your internship will automatically come to an end on closing of business/working hours of **May 31, 2019**. You will be paid a monetary stipend of **Rs. 12,000/-** per month. (all inclusive) for this period subject to deductions of applicable taxes as declared by government from time to time. No other amount directly or by way of any benefits (including financial benefits) will be paid to you.

The terms and conditions of this offer are as under:

- This internship is offered to you as part of your completion of studies and should not be treated as employment during/after completion of the internship.
- The nature of your role during the internship will be conveyed to you verbally or in writing from time to time.
- A very high level of efficiency, devotion to duty, integrity, secrecy and exemplary conduct is expected from you during the tenure of the assignment.
- You may be permitted to remain absent on payment of stipend, for urgent personal reasons, at the discretion of the management for a period not exceeding 10 calendar days, during the above period. Generally it should be by taking prior permission from your manager.
- If you choose to terminate the assignment, you shall be required to serve a 15 days' notice period. The management reserves the right to terminate your assignment even before the expiry of this internship period by giving you 15 days' notice or 15 days stipend in lieu of notice.
- You will not during the continuance of your assignment, without the consent in writing from the Company, be employed or interested directly or indirectly, in any other trade or business, employment or occupation whatsoever and will devote the whole of your time and attention to your assignment.
- You shall not at any time either during the continuance of your assignment or at any time thereafter except after obtaining prior permission in writing from the Company, use for yourself or divulge or disclose either directly or indirectly to any person, firm or body corporate any knowledge, information, trade secret, financial or commercial matter which you may acquire during the course of or incidental to your internship.
- You will not any time hereafter, without the consent in writing from the Company, except under legal process, divulge or utilize any matters relating to the Company's transactions or dealings, which are of a confidential nature.

TeraShine Technologies

#137, K.H Road, Near Bharatham Stores,
Ayanavaram, Chennai - 10



DATE: 08.01.19

Sub: Internship Acceptance Letter

TO WHOMSOEVER IT MAY CONCERN

I am pleased to confirm that Mr/Ms **A.AHMED MUSTHAFA (Reg.No:160282602005)**, pursuing his/her Final Year Master of Computer Applications in **CRESCENT INSTITUTE**, has accepted his/her Internship Project Work at a pay rate Rs.5000/- of stipend in our organization for a period of Four Months from January 2019 to April 2019.



Website : www.terashine.in
E-mail : info.terashine@gmail.com
Contact : 87 78 65 52 66



San Software Solutions

Think.. Design.. Implement.. Output..

Date: 04.01.2019

Sub: Internship Project Confirmation Letter

TO WHOMSOEVER IT MAY CONCERN

This is to Certify that **Mr. Ajmal Basa B (REG NO : 160282602006)**
MCA Final Year Student of B.S Abdur Rahman Crescent Institute of Science &
Technology has Accepted his Internship Project Work in our organization at
Java - Technology from **Jan 2019** to **May 2019**.

For **SAN SOFTWARE SOLUTIONS**



HR Manager

San Software Solutions

New No: 93, 2nd Floor, Lakshmi Tower, Kodambakkam, Chennai - 600024

E - info@sansoftwareolutions.com | M - +91 77081 50152 | web - www.sansoftwareolutions.com

REF: ORIANA/INT/130/2018-2019

02nd January 2019

Ms. B. Bhakyalakshmi,

Reg.No. 160282602013,

MCA – B.S. Abdur Rahman Crescent Institute of Science and Technology

Chennai.

Subject: Internship Offer

Dear Bhakyalakshmi,

In reference to your application we would like to congratulate you on being selected for internship with us. Your internship is scheduled to start effective **January 2019** and will end on approximately **May 2019**. All of us at **Oriana Information Technologies LLP.**, are excited that you will be joining our team!

During your internship, you may come across confidential business information. By accepting this internship, you acknowledge that you must adhere to the company's confidentiality policy. In addition, upon conclusion of your internship, you must return all company-owned property, equipment, documents and other informations.

As such, your internship will include training/orientation and focus primarily on learning and developing new project ideas & implementation and gaining a deeper understanding of concepts through hands-on application of the knowledge whereas the outstanding performance would be recognized & appraised with stipend.

The project details and technical platform will be shared with you on or before commencement of internship.

For Oriana Information Technologies LLP.,

A. Srinivasan

Authorized Signature

+91 44 66255663
info@orianainfotech.com
www.orianainfotech.com

Oriana Information Technologies LLP.

51, First floor, Tower B, TEK Meadows, Sholinganallur, Chennai – 600 119.



edu2020

Artictern Consultancy Services Private Limited

No 7, Bharathiyar Street, Inner Ring Road, Chennai: 600091.

14th January 2019

**Deepika Prabhakar,
CRESENT UNIVERSITY, CHENNAI
Email: deepikajayprabhakar@gmail.com**

Dear Deepika,

Congratulations! We are delighted to offer you an Internship Opportunity with us at Edu2020.

You will be taking up this internship from our office. Laptop is required to take up internship with Edu2020. The duration of your internship will be for four months. Your date of appointment is effective from your date of joining, which shall be on or before 18th January, 19.

We have pleasure in appointing you as Associate Web Developer at Edu2020. Based on the requirements you may be assigned tasks in various fields irrespective of your position in Edu2020. This in turn will give you exposure to working on various platforms thus learning to manage critical situations and also you will be involved in decision-making process, which in turn helps you develop your leadership qualities.

Your appointment will be governed by the terms and conditions presented in the **Annexure A**.

We look forward to you joining us. Please do not hesitate to call us +91 9445552020 for any information you may need. Also, please confirm your acceptance through reply mail.

**Mukeshkanna Nagrajan
Managing Director**



2nd Floor, Old No. 20, New No. 39, North Usman Road,
T. Nagar, Chennai - 600 017.
Voice: 044 - 4861 2901 / 2902 / 2903
Email: hr@aadhityaainfo.com URL: www.aadhityaainfo.com

AAD/CL/13028/18-19

18/01/2019

To

The Head of Department,
Department of Computer Applications,
B.S Abdur Rahman Crescent Institute of Science & Technology,
Vandalur,
Chennai - 600 048.

Respected Sir/Madam,

Sub: INTERNSHIP PROGRAMME CONFIRMATION

This is to certify that Ms. DIVYA .S (REG.NO: 160282602015) student of MCA of B.S. ABDUR RAHMAN CRESCENT INSTITUTE OF SCIENCE & TECHNOLOGY is accepted to do her "INTERNSHIP PROGRAMME" during the period from January 2019 to May 2019 in our Company.

For Aadhityaa Infomedia Technologies,

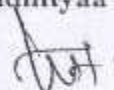
Manager - Administration.



ISO 9001 : 2008
BY AIAO - BAR



ISO / IEC 20000
BY ASCB(E)



'ACHIEVEMENT' AWARD
FOR EXCELLENT QUALITY
FROM AGS - US



IRQAO CERTIFIED
FOR INTERNATIONAL
QUALITY FOR SOFTWARE



TRUST ME -
CRISIL VERIFIED
& CERTIFIED



"BHARTHIYA UDYOG
RATAN" - AWARDED

REF: ORIANA/INT/130/2018-2019

08th January 2019

Mr. A. Firdhos,

Reg.No. 160282602018,

MCA – B.S. Abdur Rahman Crescent Institute of Science and Technology

Chennai.

Subject: Internship Offer

Dear Firdhos,

In reference to your application we would like to congratulate you on being selected for internship with us. Your internship is scheduled to start effective **January 2019** and will end on approximately **May 2019**. All of us at **Oriana Information Technologies LLP.,** are excited that you will be joining our team!

During your internship, you may come across confidential business information. By accepting this internship, you acknowledge that you must adhere to the company's confidentiality policy. In addition, upon conclusion of your internship, you must return all company-owned property, equipment, documents and other informations.

As such, your internship will include training/orientation and focus primarily on learning and developing new project ideas & implementation and gaining a deeper understanding of concepts through hands-on application of the knowledge whereas the outstanding performance would be recognized & appraised with stipend.

The project details and technical platform will be shared with you on or before commencement of internship.

For Oriana Information Technologies LLP.,



Authorized Signature

+91 44 66255663
info@orianainfotech.com
www.orianainfotech.com

Oriana Information Technologies LLP.

51, First floor, Tower B, TEK Meadows, Sholinganallur, Chennai – 600 119.

REF: ORIANA/INT/130/2018-2019

02nd January 2019

Mr. A. Fousiya Begum,

Reg.No. 160282602019,

MCA – B.S. Abdur Rahman Crescent Institute of Science and Technology

Chennai.

Subject: Internship Offer

Dear Fousiya Begum,

In reference to your application we would like to congratulate you on being selected for internship with us. Your internship is scheduled to start effective **January 2019** and will end on approximately **May 2019**. All of us at **Oriana Information Technologies LLP.**, are excited that you will be joining our team!

During your internship, you may come across confidential business information. By accepting this internship, you acknowledge that you must adhere to the company's confidentiality policy. In addition, upon conclusion of your internship, you must return all company-owned property, equipment, documents and other informations.

As such, your internship will include training/orientation and focus primarily on learning and developing new project ideas & implementation and gaining a deeper understanding of concepts through hands-on application of the knowledge whereas the outstanding performance would be recognized & appraised with stipend.

The project details and technical platform will be shared with you on or before commencement of internship.

For **Oriana Information Technologies LLP.**,



Authorized Signature

+91 44 66255663
info@orianainfotech.com
www.orianainfotech.com

Oriana Information Technologies LLP,
51, First floor, Tower B, TEK Meadows, Sholinganallur, Chennai – 600 119.



Date - 05/01/2018

To

The Head of the Department,

MCA (Computer Application),

B.S Abdur Rahman Crescent Institute of Science & Technology,
Chennai.

Subject: **Internship Project Acceptance Letter**

Dear Sir/Madam,

I am pleased to inform that **Mr. Gopi Krishnan R** - 160282602022, Final Year **MCA Computer Application, B.S Abdur Rahman Crescent Institute of Science & Technology, Chennai** on behalf of Zeal Soft Technology Solutions that your proposal for Internship Training for the period of 5 Months from **Jan 2019 to May 2019** has been accepted by the Management of Zeal Soft.

This was based on your Request Letter and the discussion that you did with us.

With best wishes and regards,



Corporate Office:

#24B/1, Soundarya Towers 2nd Floor, Kuruvikaran salai 2nd Street, Annanagar, Madurai - 20.
Phone: 0452 - 4210352 / 4210354.

Branch Address - No.3, Sri Lakshmi Homes, F-3 5th Street, Avvai Thiru Nagar, Koyembedu,
Chennai - 600 093. Web - <http://www.zealsoft.net>

AAD/CL/13028/18-19

18/01/2019

To

The Head of Department,
Department of Computer Applications,
B.S Abdur Rahman Crescent Institute of Science & Technology,
Vandalur,
Chennai - 600 048.

Respected Sir/Madam,

Sub: INTERNSHIP PROGRAMME CONFIRMATION

This is to certify that Ms. ISHVARYA .S (REG.NO: 160282602027) student of MCA of B.S. ABDUR RAHMAN CRESCENT INSTITUTE OF SCIENCE & TECHNOLOGY is accepted to do her "INTERNSHIP PROGRAMME" during the period from January 2019 to May 2019 in our Company.

For Aadhityaa Infomedia Technologies,

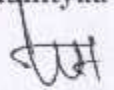
Manager - Administration.



ISO 9001 : 2008
BY AIAO - BAR



ISO / IEC 20000
BY ASCB(E)



"ACHIEVEMENT" AWARD
FOR EXCELLENT QUALITY
FROM AGS - US



IRQAO CERTIFIED
FOR INTERNATIONAL
QUALITY FOR SOFTWARE



TRUST ME -
CRISIL VERIFIED
& CERTIFIED



"BHARTHIIYA UDYOG
RATAN" - AWARDED



**GHOST
VISION Pvt Ltd**

CIN number - U74999TN2017PTC118156

c/o IIT Madras Research Park
03 A2 Third Floor, Research
Park, Kanagam Road, Taramani,
Chennai - 600113, Tamil Nadu

Date : February 1st, 2019

Dear Jahaber Shaik Allavudeen,

We would like to congratulate you on being selected for the Programming and mobile application development internship position with Ghost Vision. All of us at Ghost Vision are excited that you will be joining our team!

This internship is viewed by us as being an educational opportunity for you, rather than a part-time job. As such, your internship will include training/orientation and focus primarily on learning and developing new skills and gaining a deeper understanding of concepts through hands-on application of the knowledge you learned in class.

You shall be reporting directly to your commanding officer- Mr Jeshurun Edward, also you will be supervised by the CEO- Kumar Mridul.

Again, congratulations and we look forward to working with you this coming year.

Sincerely,

Kumar Mridul
Founder and CEO

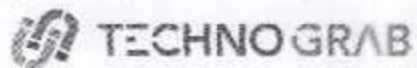

41B, Jeshwanth Nagar, Mogappair West, Chennai - 37
Phone : +91 9944818535 . Email : nadesan@technograb.co
www.technograb.co

Chennai
17 January 2019

Jayashree S
145/147, Ayyasamy Street,
West Tambaram, Chennai - 600045

Dear Jayashree,

We would like to congratulate you on being selected for the Trainee Internship position with Ceino Technologies Pvt. Ltd. effective 17 Jan 2019. All of us at ceino are excited that you will be joining our team!

Sincerely

Nadesan G
CEO, TECHNOGRAB

A. Jayashree



San Software Solutions

Think... Design... Implement... Output...

Date: 04.01.2019

Sub: Internship Project Confirmation Letter

TO WHOMSOEVER IT MAY CONCERN

This is to Certify that **Mr. Mathivanan S (REG NO : 160282602041)**
MCA Final Year Student of **B.S Abdur Rahman Crescent Institute of Science &**
Technology has Accepted his Internship Project Work in our organization at
Java - Technology from **Jan 2019 to May 2019.**

For **SAN SOFTWARE SOLUTIONS**

HR Manager

San Software Solutions

New No: 93, 2nd Floor, Lakshmi Tower, Kodambakkam, Chennai - 600024

E - info@sansoftwareolutions.com | M - +91 77081 50152 | web - www.sansoftwareolutions.com



Date - 05/01/2018

To

The Head of the Department,

MCA (Computer Application),

B.S Abdur Rahman Crescent Institute of Science & Technology,
Chennai.

Subject: Internship Project Acceptance Letter

Dear Sir/Madam,

I am pleased to inform that **Mr. Mohamed Abdul Hussain A** - 160282602045, Final Year **MCA** Computer Application, **B.S Abdur Rahman Crescent Institute of Science & Technology, Chennai** on behalf of Zeal Soft Technology Solutions that your proposal for Internship Training for the period of 5 Months from **Jan 2019 to May 2019** has been accepted by the Management of Zeal Soft.

This was based on your Request Letter and the discussion that you did with us.

With best wishes and regards,

A handwritten signature in black ink is written over a circular stamp. The stamp contains the text 'Zealsoft Technology Solution' around the perimeter and some illegible text in the center.

Corporate Office:

#24B/1, Soundarya Towers 2nd Floor, Kuruvikaran salai 2nd Street, Annanagar. Madurai - 20.
Phone: 0452 - 4210352 / 4210354.

Branch Address - No.3, Sri Lakshmi Homes, F-3 5th Street, Avvai Thiru Nagar, Koyembedu,
Chennai - 600 093. Web - <http://www.zealsoft.net>



Date:02-01-2019

Dear **Mohamed Fairojudeen,**

Venba Information Technology is pleased to offer you an educational internship opportunity as a Software Developer Intern. You will report to directly to Kannan. This position is located in Gowrivakkam – Chennai.

As you will be receiving Academic credit for this position, you will not be paid. Additionally, Students do not receive benefit as part of their internship program.

Congratulations and welcome to the team!

Sincerely,





TECHCOZMOS

18-01-2019

TO WHOMSOEVER IT MAY CONCERN

Dear **Mohamed Hajjithukarudeen S.**

TECHCOZMOS is pleased to offer you an educational internship opportunity as a embed system designer intern. You will report to directly Yesumani. This position is located in Thiruvavarur. As you will be receiving academic credit for this position, you will not be paid, additionally students do not receive benefit as part of the internship program.

Congratulations and welcome to the Team.



Mr. Mohamed Shakeel . A

8th January 2019

Reg. No. 160282602051

B.S. Abdur Rahman Crescent Institute of Science and Technology
Chennai.

Dear Shakeel,

Sub: Internship

On behalf of **Shiash Info Solutions Private Limited**. We would like to inform that you are being accepted as one of our interns. We are pleased to inform you that you have been qualified as per the requirements for the internship. You will be working with our Technical team.

Your internship will begin with effective from **January 2019 to May 2019**. You will be assigned to various tasks which relates to the project assigned to you after which your performance will be assessed and appraised.

For Shiash Info Solutions Private Limited

Sahithya M



Sr. HR Executive

Shiash Info Solutions Private Limited
Level 1, Tower B, TEK Meadows, No. 51, Elcot Sez,
Sholinganallur, Chennai- 600 119, Tamilnadu, India.

+91 44 66255681 ■ info@shiash.com



FAYONICS EMBEDDED TECHNOLOGIES
RIGHT IDEAS BETTER SOLUTIONS

Mohamed udhuman a.k

12th January 2019

Rm:160282602052

B.S.Abdur Rahman Crescent Institute of Science and Technology
Chennai.

Dear Mohamed Udhuman a.k

We are pleased to offer you an internship program with Fayonics embedded technologies for a period of five months.

You should note that any information and data collected from you during the course of your internship should be kept confidential at all times.

We appreciate your interest in Fayonics embedded technologies

Yours Sincerely,

Kamila Riyaz
HR Manager
Fayonics embedded technologies

127/35F/1, Pudumanni Street
Adirampattinam-614701
894 056 9561

Ms. K. Nandhini

19th November 2018

Reg. No. 160282602057

B.S. Abdur Rahman Crescent Institute of Science and Technology
Chennai.

Dear Nandhini,

Sub: Internship

On behalf of **Shiash Info Solutions Private Limited**. We would like to inform that you are being accepted as one of our interns. We are pleased to inform you that you have been qualified as per the requirements for the internship. You will be working with our Technical team.

Your internship will begin with effective from **December 2018 to May 2019**. You will be assigned to various tasks which relates to the project assigned to you after which your performance will be assessed and appraised.

For **Shiash Info Solutions Private Limited**



Sahithya M

Sr. HR Executive

Shiash Info Solutions Private Limited

Level 1, Tower B, TEK Meadows, No. 51, Elcot Sez,
Sholinganallur, Chennai- 600 119, Tamilnadu, India.

☎ +91 44 66255681 ✉ info@shiash.com

Offer Letter

January 9, 2019

Dear Nikitha N,

Congratulations!

We are happy to Offer you employment at Infodsign Technology for the duration of 3 months. We feel that your skills and background will be valuable assets to our team. Further to our discussion and the subsequent Interviews, you have been selected as "Engineer (Intern)". (Refer Annexure I).

Your Stipend will be based on your performance.

The D.O.J. will inform you later.

Kindly sign the duplicate copy of this letter and return it as a token of acceptance.

Regards,



Murali T
Asst. Manager

Accepted

Annexure I



ProsInd Technologies
Phase III, Hariohm Street,
Anna Nagar West,
Chennai - 600 040.
Website: www.prosind.in
E-mail: prosindtech@yahoo.com
Contact No : 9994238847

08.01.19

Sub: Internship Acceptance

TO WHOMSOEVER IT MAY CONCERN

I am pleased to confirm that Mr S.PRABHAKAR (Reg.No:160282602063), pursuing his Final Year **Master of Computer Applications** in **CRESCENT INSTITUTE**, has accepted his Internship Project Work at a pay rate Rs.5500/- of stipend in our organization from January 2019 to April 2019.

Regards,

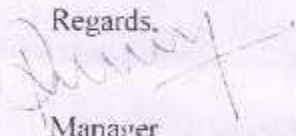
Manager

Ms. SV. Prathiksha

10th November 2018

Reg. No. 160282602065

B.S. Abdur Rahman Crescent Institute of Science and Technology
Chennai.

Dear Prathiksha,

Sub: Internship

On behalf of Shia#sh Info Solutions Private Limited, We would like to inform that you are being accepted as one of our interns. We are pleased to inform you that you have been qualified as per the requirements for the internship. You will be working with our Technical team.

Your internship will begin with effective from December 2018 to May 2019. You will be assigned to various tasks which relates to the project assigned to you after which your performance will be assessed and appraised.

For Shia#sh Info Solutions Private Limited

Sahithya M.
Sr. HR Executive



Shia#sh Info Solutions Private Limited
Level 1, Tower B, TEK Meadows, No. 51, Elcot Sez,
Sholinganallur, Chennai- 600 119, Tamilnadu, India.
☎ +91 44 66255681 ✉ info@shia#sh.com

www.shia#sh.com

January 4, 2018

To

Priyanka S,
Department of Computer Application,
BSA Crescent Institute of science & Technology,
Chennai.

Dear Priyanka S,

Congratulations!

This is to inform you that you are going to work with our development team as a Developer Intern. During this period you will be working in the below mentioned project.

TITLE: Digital Industry Network Management Application (DINM)

Approved by



Prabhakaran
Technical Manager

During this internship the enclosed project information which is confidential and the copyright of Infodsign Technology. This project may also contain Confidentiality and legally privileged information. The information distribution, disclosure or copying of this project is strictly prohibited without the express written approval of Infodsign Technology.

Ms. M. Raga Sudha

Reg. No. 160282602069

B.S. Abdur Rahman Crescent Institute of Science and Technology
Chennai.

22nd November 2018

Dear Raga Sudha,

Sub: Internship

On behalf of **Shiash Info Solutions Private Limited**, We would like to inform that you are being accepted as one of our interns. We are pleased to inform you that you have been qualified as per the requirements for the internship. You will be working with our Technical team.

Your internship will begin with effective from **December 2018 to May 2019**. You will be assigned to various tasks which relates to the project assigned to you after which your performance will be assessed and appraised.

For **Shiash Info Solutions Private Limited**

Sahithya M



Sr. HR Executive

Shiash Info Solutions Private Limited
Level 1, Tower B, TEK Meadows, No. 51, Elcot Sez,
Sholinganallur, Chennai- 600 119, Tamilnadu, India.
☎ +91 44 66255681 ■ info@shiash.com

www.shiash.com

Shia#sh
Focus on Deliverables

Ms. B. Ramya

22nd November 2018

Reg. No. 160282602071

B.S. Abdur Rahman Crescent Institute of Science and Technology
Chennai.

Dear Ramya,

Subj: Internship

On behalf of **Shiash Info Solutions Private Limited**. We would like to inform that you are being accepted as one of our interns. We are pleased to inform you that you have been qualified as per the requirements for the internship. You will be working with our Technical team.

Your internship will begin with effective from **December 2018 to May 2019**. You will be assigned to various tasks which relates to the project assigned to you after which your performance will be assessed and appraised.

For **Shiash Info Solutions Private Limited**



Sahithya M

Sr. HR Executive

Shiash Info Solutions Private Limited
Level 1, Tower B, TEK Meadows, No. 51, Elcot Sez,
Sholinganallur, Chennai- 600 119, Tamilnadu, India.

+91 44 66255681 ■ info@shiash.com

www.shiash.com

Mr. R. N. Sabarish

19th November 2018

Reg. No. 160282602074

B.S. Abdur Rahman Crescent Institute of Science and Technology
Chennai.

Dear Sabarish,

Sub: Internship

On behalf of **Shiash Info Solutions Private Limited**. We would like to inform that you are being accepted as one of our interns. We are pleased to inform you that you have been qualified as per the requirements for the internship. You will be working with our Technical team.

Your internship will begin with effective from **December 2018 to May 2019**. You will be assigned to various tasks which relates to the project assigned to you after which your performance will be assessed and appraised.

For **Shiash Info Solutions Private Limited**



Sanithya M

Sr. HR Executive

Shiash Info Solutions Private Limited

Level 1, Tower B, TEK Meadows, No. 51, Elcot Sez,
Sholinganallur, Chennai- 600 119, Tamilnadu, India.

☎ +91 44 66255681 ✉ info@shiash.com

Offer Letter

November 19th, 2018

Dear Sanjai E

Congratulations!

We are happy to Offer you employment at Infodsign Technology for the duration of 3 months. We feel that your skills and background will be valuable assets to our team. Further to our discussion and the subsequent Interviews, you have been selected as "**Developer (Intern)**". (Refer Annexure I).

Your Stipend will be based on your performance.

The D.O.J. will inform you shortly.

Kindly sign the duplicate copy of this letter and return it as a token of acceptance.

Regards,

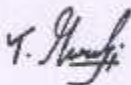

Murali T
Asst. Manager

Accepted



Candid
Techno Solutions

CANDID TECHNO SOLUTIONS

☎ 044- 2847 2352

✉ info@candidtec.com

📍 #27, Krishna Street, Rajeswari Avenue,
Madnanthapuram, Porur,
Chennai- 116

🌐 www.candidtec.com

Mr. A. Sarafaraz

Reg No: 160282602080

Crescent University

Chennai.

Dear Sarafaraz,

We are pleasure to inform you that, on consequent, to the review of your performance and your academic credentials as doing final year **MCA (Master of Computer Applications)** in **Crescent University, Chennai**, You being confirmed to do your project in our organization with effect from **December 2018 to May 2019**.

We wish you very best in your performance towards our organization.

For **Candid Techno Solutions**,



Akshay Menon

HR Manager



Candid
Techno Solutions

CANDID TECHNO SOLUTIONS



044- 2847 2352



info@candidtec.com



#27, Krishna Street, Rajeswari Avenue
Madnanthapuram, Porur.
Chennai- 116



www.candidtec.com

Mr. K. Shaik Naina Maricar

Reg No: 160282602081

Crescent University

Chennai.

Dear Shaik Naina,

We are pleasure to inform you that, on consequent, to the review of your performance and your academic credentials as doing final year MCA (**Master of Computer Applications**) in **Crescent University, Chennai**, You being confirmed to do your project in our organization with effect from **December 2018 to May 2019**.

We wish you very best in your performance towards our organization.

For Candid Techno Solutions,



Akshay Menon

HR Manager



CANDID TECHNO SOLUTIONS

☎ 044- 2847 2352

✉ info@candidtec.com

📍 #27, Krishna Street, Rajeswari Avenue
Madnanthapuram, Porur.
Chennai- 116

🌐 www.candidtec.com

Ms. S. Shereen Parvin

Reg No: 160282602084

Crescent University

Chennai.

Dear Parvin,

We are pleasure to inform you that, on consequent, to the review of your performance and your academic credentials as doing final year **MCA (Master of Computer Applications)** in **Crescent University, Chennai**, You being confirmed to do your project in our organization with effect from **December 2018 to May 2019**.

We wish you very best in your performance towards our organization.

For Candid Techno Solutions,

A handwritten signature in black ink, which appears to read 'Akshay Menon', is written over a circular stamp. The stamp contains the text 'CANDID TECHNO SOLUTIONS' around the perimeter, 'CHENNAI' in the center, and '800 118' at the bottom. There is a small star symbol at the bottom center of the stamp.

Akshay Menon

HR Manager

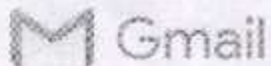

siva shama <shivashamaa@gmail.com>

PTO - Waffor Retails Solutions campus drive - Students selected for Interns cum Placement - Reg

1 message

Director - Placement & Training <bsaplacement@cresecent.education>

Fri, Jan 11, 2019 at 2:54 PM

To: srinu venkat nice <srinuvenkatnice@gmail.com>, siva shama <shivashamaa@gmail.com>

Cc: HOD CSE <hodcse@cresecent.education>, HOD CA <hodca@cresecent.education>, thinakaran@cresecent.education, radhika.a@cresecent.education

Dear Students,

Greetings from Placement & Training..

We are pleased to inform you that, the following students have been selected for Internship cum Placement by Waffor Retail Solutions (P) Ltd campus drive process held on 10th Jan.2019 (yesterday) at our University premises.

1. Venkata Srinivasalu - B.Tech. / CSE - Software Engineer
2. Sivasankari G - MCA - Software Engineer

The above students are instructed to report the company on **18th Jan.2019** positively.

Hearty Congratulations to the Successful candidates..!!

Thanks and Regards,

Dr.Ganesh K

Director - Placement & Training, Industry Institute Partnership Cell

Nodal Resource-Center Coordinator - SRC, IIT Bombay, MHRD, Govt. of India.

Member Committee - HR & IR Panel - FICCI (Federation of Indian Chambers of Commerce and Industry - New Delhi)

B.S. A. Crescent Institute of Science & Technology (Deemed to be University)

"Seethakathi Estate", G.S.T Road | Vandalur | Chennai

Tamil Nadu - 600048.

Tel:- 044-22751347 / 48 / 50 Ext:232

Mobile:- +91 9962244626 / 795

E-mail : placement@cresecent.education

www.bsainiv.ac.in



December 14, 2018

Principal,
Crescent Institute of Science & Technology,
Chennai 600048

Dear Sir,

This has reference to your letter regarding internship of the following student pursuing Postgraduate in Computer Application from your institution in our organization.

Ms. R. Sruthi(1602826002087)

We agree to admit her for Internship for a duration from 26th December – 10th may in our organization. She is advised to report at the following address.

Bluish Technologies,
#45, Kamaraj Salai, Thattanchavady,
Pondicherry 605 009.

Contact Person : Mr. R.KARTHIKEYAN
Contact Number: 9659305028

Please note that she has to undergo the training without any financial commitment to the Company and fully at her risk and responsibility. Format of Indemnity bond to this effect is enclosed. She need to send us the same on stamp paper dully signed by her and notarized.

Sincerely,
For BLUISH TECHNOLOGIES

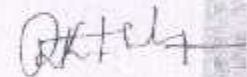

BRANCH MANAGER
R.KARTHIKEYAN



OUR SERVICES

SOFTWARE DEVELOPMENT | WEB DEVELOPMENT | SEO | WEB DESIGNING | MOBILE APPS

Mr. M. Syed Aboo Thahir

08th January, 2019

Reg. No. 160282602090

B. S. Abdur Rahman Crescent Institute of Science and Technology

Chennai.

Dear Thahir,

Sub: Internship

On behalf of **Shiash Info Solutions Private Limited**. We would like to inform that you are being accepted as one of our interns. We are pleased to inform you that you have been qualified as per the requirements for the internship. You will be working with our Technical team.

Your internship will begin with effective from **January 2019 to May 2019**. You will be assigned to various tasks which relates to the project assigned to you after which your performance will be assessed and appraised.

For **Shiash Info Solutions Private Limited**

Shwetha M



Sr. HR Executive

Shiash Info Solutions Private Limited

Level 1, Tower B, TEK Meadows, No. 51, Elcot Sez,
Shotinganallur, Chennai- 600 119, Tamilnadu, India.

+91 44 66255681 ■ info@shiash.com



CANDID TECHNO SOLUTIONS

☎ 044- 2847 2352

✉ info@candidtec.com

📍 #27, Krishna Street, Rajeswari Avenue,
Madnanthapuram, Porur,
Chennai- 116

🌐 www.candidtec.com

Mr. K. Syed Irbas Ahmed

Reg No: 160282602091

Crescent University

Chennai.

Dear Syed Irbas,

We are pleasure to inform you that, on consequent, to the review of your performance and your academic credentials as doing final year MCA (Master of Computer Applications) in Crescent University, Chennai, You being confirmed to do your project in our organization with effect from **December 2018 to May 2019**.

We wish you very best in your performance towards our organization.

For Candid Techno Solutions,



Akshay Menon

HR Manager

Mr. Y. Syed Shakir

20th November 2018

Reg. No. 160282602093

B.S. Abdur Rahman Crescent Institute of Science and Technology
Chennai.

Dear Shakir,

Sub: Internship

On behalf of Shiash Info Solutions Private Limited. We would like to inform that you are being accepted as one of our interns. We are pleased to inform you that you have been qualified as per the requirements for the internship. You will be working with our Technical team.

- Your internship will begin with effective from December 2018 to May 2019. You will be assigned to various tasks which relates to the project assigned to you after which your performance will be assessed and appraised.

For Shiash Info Solutions Private Limited



Shwetha M

Sr. HR Executive

Shiash Info Solutions Private Limited

Level 1, Tower B, TEK Meadows, No. 51, Elcot Sez,
Sholinganallur, Chennai- 600 119, Tamilnadu, India.

☎ +91 44 66255681 ✉ info@shiash.com



CANDID TECHNO SOLUTIONS

☎ 044- 2847 2352

✉ info@candidtec.com

📍 #27, Krishna Street, Rajeswari Avenue
Madnanthapuram, Porur.
Chennai- 116

🌐 www.candidtec.com

Mr. A. Thariq Mohamed

Reg No: 160282602098

Crescent University

Chennai.

Dear Thariq,

We are pleasure to inform you that, on consequent, to the review of your performance and your academic credentials as doing final year **MCA (Master of Computer Applications)** in **Crescent University, Chennai**, You being confirmed to do your project in our organization with effect from **December 2018 to May 2019**.

We wish you very best in your performance towards our organization.

For **Candid Techno Solutions**,

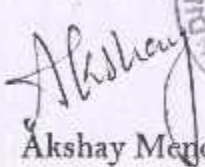
Akshay Meron

HR Manager



January 4,2018

To

Venkataramana B,
Department of Computer Application,
BSA Crescent Institute of science &Technology,
Chennai.

Dear Venkataramana B,

Congratulations!

This is to inform you that you are going to work with our development team as a Developer Intern. During this period you will be working in the below mentioned project.

TITLE: Scale Calculation & Maintenance Application (SCM)

Approved by



Prabhakaran
Technical Manager

During this internship the enclosed project information which is confidential and the copyright of Infodsign Technology. This project may also contain Confidentiality and legally privileged information. The information distribution, disclosure or copying of this project is strictly prohibited without the express written approval of Infodsign Technology.

TeraShine Technologies

#137,K.H Road, Near Bharatham Stores,
Ayanavaram Chennai 40



DATE: 08.01.19

Sub: Internship Acceptance Letter

TO WHOMSOEVER IT MAY CONCERN

I am pleased to confirm that Mr/Ms R.VIGNESH (Reg.No:160282602100), pursuing his/her Final Year Master of Computer Applications in CRESCENT INSTITUTE, has accepted his/her Internship Project Work at a pay rate Rs.5000/- of stipend in our organization for a period of Four Months from January 2019 to April 2019.



Website : www.terashine.in
E-mail : info.terashine@gmail.com
Contact : 87 78 65 52 66

January 4,2018

To

Vivekanandan N,
Department of Computer Application,
BSA Crescent institute of science &Technology,
Chennai.

Dear Vivekanandan N,

Congratulations!

This is to inform you that you are going to work with our development team as a Developer Intern. During this period you will be working in the below mentioned project.

TITLE: Offense Reporting System(ORS)

Approved by



Prabhakaran
Technical Manager

During this internship the enclosed project information which is confidential and the copyright of Infodsign Technology. This project may also contain Confidentiality and legally privileged information. The information distribution, disclosure or copying of this project is strictly prohibited without the express written approval of Infodsign Technology.

January 4,2018

To

Yuvaraj V,
Department of Computer Application,
BSA Crescent institute of science &Technology,
Chennai.

Dear Yuvaraj V,

Congratulations!

This is to inform you that you are going to work with our development team as a Developer Intern. During this period you will be working in the below mentioned project.

TITLE: Live Interaction Management Software(LIMS)

Approved by



Prabhakaran
Technical Manager

During this internship the enclosed project information which is confidential and the copyright of Infodsign Technology. This project may also contain Confidentiality and legally privileged information. The information distribution, disclosure or copying of this project is strictly prohibited without the express written approval of Infodsign Technology.

TAP

TAP TURBO ENGINEERS PRIVATE LIMITED

FlaktWoods



152, (SP) Ambattur Industrial Estate, 1st Main Road, 4th Lane, 21st Phase, Chennai - 600 058
Ph. : +91 44 2625 7234, 2625 7249. Fax : +91-44-2625 7406

TAP TURBO/INTERSHIP/2018-2019/002

DT.18.08.2018

TO,

Ms.SAI GAYATRI MAHAJAN,
BSA Crescent Institute of Science & Technology
Chennai-600 048

SUB: INTERNSHIP LETTER ..

Dear Ms.SAI GAYATRI MAHAJAN,

We are happy to inform you that Ms.SAI GAYATRI MAHAJAN - SOFTWARE ENGINEER of BSA CRESENT INSTITUTE OF SCIENCE&TECHNOLOGY can do their internship in our company from the period of 20.01.2019 to 20.03.2019 .In Rectification and up grading of REACH ERP software.

Thanking You,

TAP TURBO ENGINEERS PVT LTD

E. G

E. GOWTHAM
EXECUTIVE DIRECTOR



TUSHACO
GEAR PUMPS

Authorised Dealer : FLAKWOOD'S FANS, SAM TURBO PUMPS AND GREAVES PUMPS

Marketing Representative : TUSHACO Gear & SCREW Pumps

Consultant : For Pressure Vessels, Heat Exchanger, Storage Tanks, Chimney, Rotating Equipments & HVAC Systems

INTERNSHIP OFFER LETTER

Date: 30-Nov-2018
Place: Chennai

To
MOHAMMED ZIYYAD A
6/1, 3rd street, Ravanan Nagar,
Puzhuthivakkam, Chennai - 600091
Email: mhddziyyad@gmail.com

Dear MOHAMMED ZIYYAD A,

It is my pleasure to extend the following offer of Internship to you on behalf of Peritus Solutions Pvt Ltd, further to the interview and discussions you have had with us. You are expected to join us on 02 January 2019.

You are appointed to the position of **Software Engineer Intern** and in this capacity, you will report directly to Software Product Manager of the company.

Your working hours start from 9:30 a.m to 06:00 p.m with one-hour break a day and you are scheduled to work through Monday to Friday; Saturday will be work from home, which is 48 hours a week. You shall receive your payments on or before the 7th of every month. Offer stands cancelled in case of any deviations in information or if you fail to report to me on or before pre-decided date.

We look forward to an enduring relationship with you.

Thanks and Regards

For PERITUS SOLUTIONS PRIVATE LIMITED



Director

Syed Anif,
Chief Technology Officer
Peritus Solutions Private Limited

12, 2nd Floor, Second Street, Sri Sakthi Vijayalakshmi Nagar,
Chennai, TamilNadu, India-600042

 **PERITUS**
implementing logic practically
www.peritusglobal.com

TEKION

November 6, 2018

Shriram Chandrasekaran
5/2C, Sector -2, DIZ Area, Gole Market,
New Delhi - 110001.

Dear Shriram,

We are pleased to offer you a career opportunity with Tekion India Private Limited as Intern. The terms and conditions of our offer are set out in this letter.

You will be reporting from January 2019 and Your internship fee is INR 20,000 (Twenty thousand only) per month.

The Company shall withhold the appropriate amount of Indian income taxes from the salary paid to you. You shall be responsible for filing your personal returns and comply with other requirements under the India tax laws.

Appointment

You have been made an offer as Intern

(i) The place of employment shall be Bangalore and the normal office timings will be from 9:30AM to 6:30 PM. However, depending on the time constraint within which the Company may have to provide services to its clients, you will undertake to make yourself available in respect of the business of the Company during such times.



(ii) You may also be transferred, seconded or deputed to any of our associate, sister concerns, subsidiaries, group company or any other affiliated companies/concerns/organizations/firms with whom the Company may make an arrangement or agreement from time to time. In such cases of transfer you will be governed by the relocation policies and policies of the Company existing at that time.

Policies, Procedures, Rules & Regulations

You shall, in addition to the terms and conditions of employment specifically stated herein, also be governed by the rules, regulations and such other practices, systems, procedures and policies framed, amended, modified or omitted by the Company from time to time.

You will also be governed by statutory laws enacted by Central or State Government or local authorities as may be applicable to you from time to time including but not limited to the provisions of the Prevention of Corruption Act, 1988 of India, the Foreign Corrupt Practices Act, 1977 of the United States of America and the Bribery Act 2010 of the United Kingdom. Without limiting the generality of the foregoing, you represent and covenant that you have not, and shall not, at any time, during your employment with the Company, pay, give, or offer or promise to pay or give, any money or any other thing of value, directly or indirectly, to, or for the benefit of: (i) any public servant, government official, political party or candidate for political office; or (ii) any other person, firm, corporation or other entity, with knowledge that some, or all of that money, or other thing of value will be paid, given, offered or promised to a public servant, government official, political

Tekion India Private Ltd, #693, Ground Level, 15th Cross Road, J.P. Nagar, 2nd Phase, Bengaluru, Karnataka 560078, India

www.tekion.com |  LinkedIn.com/company/Tekion |  @tekioncorp

trail

Project Internship Confirmation

To Whomscever it may concern

Date: 19th November, 2018

This is to inform that Mr. N.Imtiaz and Mr. K.V.S. Bharath, Engineering graduands, from B.S. Abdur Rahman Crescent Institute of Science and Technology, Chennai, were confirmed for the Project Internship at Trail Cloud Innovation Services Pvt. Ltd., Chennai, until March 2019.

For Trail Cloud Innovation Services Pvt. Ltd.,

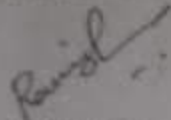

V. Ravishankar
Vice President - Operations

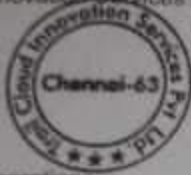



Director - Placement & Training

to nscubey, me, saba.mahesh, vc, registrar, , deans...
15:31 View details

Dear All..

Greetings from Placement & Training Cell !!

Our Management, Vice-Chancellor, Registrar, All Department Director's, Dean's, HoD's and Director-Placement & Training Cell Congratulate the following Three B.Tech. students for meritorious achievement in the campus drive conducted by M/s. Newgen Software Technologies Limited on 8th January, 2019 at our University premises with Salary package of Rs. 3.75/- LPA. We are expecting similar laurels from other students in the future.

1. Mr. Shaik Asib Ahammed - B.Tech. CSE
2. Mr. Sreesh Kumar - B.Tech. CSE
3. Mr. Sabareesh M - B.Tech. IT

These students are requested to report on 25th February '19 at their Chennai Office.

They will undergo the one month product training till 28th March '19 and then they will give them the required leaves for attending the exams/practical / viva as per the schedules which department will share with us.

Kindly confirm the same at the earliest.

Hearty Congratulations to the Successful Students...!

Thanks and Regards,

Dr. Ganesh K

Director - Placement & Training, Industry Institute Partnership Cell

Nodal Resource Center Coordinator - SRC, IIT Bombay, MHRD, Govt. of India.

Member Committee - HR & IR Panel - FICCI (Federation of Indian Chambers of Commerce and Industry - New Delhi)

B.S. A. Crescent Institute of Science & Technology (Deemed to be University)
"Seethakathi Estate", G.S.T Road | Vandalur | Chennai

TEKION

November 6, 2018

Shaik Mutahhara
3/548, Anjuman Street, Nandyal, Kurnool district,
Andhra Pradesh-518501

Dear Mutahhara,

We are pleased to offer you a career opportunity with Tekion India Private Limited as Intern. The terms and conditions of our offer are set out in this letter.

You will be reporting from January 2019 and Your Internship fee is INR 20,000 (Twenty thousand only) per month.

The Company shall withhold the appropriate amount of Indian income taxes from the salary paid to you. You shall be responsible for filing your personal returns and comply with other requirements under the India tax laws.

Appointment

You have been made an offer as Intern

(i) The place of employment shall be Bangalore and the normal office timings will be from 9.30AM to 6.30 PM. However, depending on the time constraint within which the Company may have to provide services to its clients, you will undertake to make yourself available in respect of the business of the Company during such times.



(ii) You may also be transferred, seconded or deputed to any of our associate, sister concerns, subsidiaries, group company or any other affiliated companies/concerns/organizations/firms with whom the Company may make an arrangement or agreement from time to time. In such cases of transfer you will be governed by the relocation policies and policies of the Company existing at that time.

Policies, Procedures, Rules & Regulations

You shall, in addition to the terms and conditions of employment specifically stated herein, also be governed by the rules, regulations and such other practices, systems, procedures and policies framed, amended, modified or omitted by the Company from time to time.

You will also be governed by statutory laws enacted by Central or State Government or local authorities as may be applicable to you from time to time including but not limited to the provisions of the Prevention of Corruption Act, 1988 of India, the Foreign Corrupt Practices Act, 1977 of the United States of America and the Bribery Act 2010 of the United Kingdom. Without limiting the generality of the foregoing, you represent and covenant that you have not, and shall not, at any time, during your employment with the Company, pay, give, or offer or promise to pay or give, any money or any other thing of value, directly or indirectly, to, or for the benefit of: (i) any public servant, government official, political party or candidate for political office; or (ii) any other person, firm, corporation or other entity, with knowledge that some, or all of that money, or other thing of value will be paid, given, offered or promised to a public servant, government official, political

Tekion India Private Ltd, #593, Ground Level, 15th Cross Road, J.P. Nagar, 2nd Phase, Bengaluru, Karnataka 560078, India

www.tekion.com |  LinkedIn.com/company/Tekion |  @tekioncorp



Ridha Prints Crescent <ridhacrescent@gmail.com>

Fwd: Internship Application

message

Aaron Khan <aaronkhan1998@gmail.com>
To: ridhacrescent@gmail.com

Tue, Jan 22, 2019 at 12:20 PM

Forwarded message

From: **Preeti Tewatia** <Preeti.Tewatia@in.ey.com>
Date: Mon 21 Jan, 2019, 12:17 PM
Subject: Internship ApplicationTo: aaronkhan1998@gmail.com <aaronkhan1998@gmail.com>
Cc: Varun K Babu <Varun1.Kumar@in.ey.com>, Vikas Sarolia <Vikas.Sarolia@in.ey.com>, Pallavi Trivedi <pallavi.trivedi@in.ey.com>, Sharanya K <Sharanya.K@in.ey.com>

Dear Aaron,

We are pleased to make you an offer as an Intern at our Chennai Office

Duration : 23-Jan-2019 – 23-Apr-2019

Ernst & Young Pvt Ltd (Tidel Park, 7th Floor -A Block (Module 601, 701-702) N0 4, Rajiv Gandhi Salai Taramani, Chennai, , Tamil Nadu, 600 113), India.

Please report to your project mentor on the date of your joining as per the details mentioned below

Project Mentor : Varun K babu

Contact number: 9884373422

Please send a Reply all to this mail acknowledging the acceptance of the offer and confirming your date of joining.

You would be required to bring your laptop and data-card during the period of internship. Your laptop should contain MS Office applications and anti-virus software.

Look forward to a mutually beneficial association with you and wish you luck.

Note: For any related query, kindly connect with your service line HR Sharanya K Sharanya.K@in.ey.com

Regards,

Preeti Tewatia | Human Resources

cid:image001.gif@01D099BB.5900C0A0

Ernst & Young Services Pvt. Ltd.

Golf View Corporate Tower-B, Sector 42, Sector Road, Gurgaon, Haryana 122022,
IndiaOffice: +91 124-671 4000 | Preeti.tewatia@in.ey.com



Spencer Express Avenue
EA Chambers Tower 1 - 5th Floor
No 46/033, White Road, Royapettah, Chennai,
Tamil Nadu 600002, India
PH 8829 2233 www.sidsync.com

Project Internship Confirmation Certificate
To whomsoever it may concern

Date: 24th January 2019

This is to inform that Mr. JOSHUA J., Student of B.S. Abdur Rahman Crescent Institute of Science and Technology is confirmed for the project internship at Sidsync Technologies Private Limited, Chennai for 3 months, starting from January 2019.

No Stipend will be paid during the project internship period at Sidsync Technologies Private Limited.





INTERNSHIP APPOINTMENT CONFIRMATION

07/06/2018
Chennai

Habeebur Rahman
Student, Final Year, Information Technology
B.S.A Crescent Institute of Science and Technology
Chennai

Dear Habeebur Rahman

Please consider this letter a confirmation of Internship in the Immigration Project for the client called Transcripts Guru effective June 11, 2018 through June 30, 2018 for 40 hours per week at no compensation.

This appointment has been recommended by your university results and your academic excellence witnessed by your college/university staff. On the basis that you will perform development of application testing and deployment. In performing these duties you will be responsible to deliver and you should direct any inquiries to Vigneswaran Paramathayalan, Chair-Cloud Bull India Operations

Cloud Bull will be able to reimburse you for travel and accommodation expenses up to a maximum of \$350 per day if in case of international travel. We will need original receipts for these charges. Please provide us with proof of medical insurance and a photocopy of your passport and visa.

If in case we shortlist you for an international travel, Cloud Bull will provide you with forms to apply for a B1 visa to US at your nearest United States Embassy or Consular Office.

Upon arrival to campus, contact Vigneswaran Paramathayalan

Please indicate in the space provided below whether you accept this confirmation of this internship and return it to me as soon as possible. The duplicate of this letter is for your personal file. (Please note that you are receiving two original copies of this letter. You will need the second original when you apply for your visa at the United States Embassy)

We appreciate your interest in volunteering for internship and welcome your contribution to Cloud Bull India

Sincerely,



VIGNESWARAN PARAMATHAYALAN



I hereby accept the above offer of volunteer appointment as stated above
(accept/decline)

11/06/2018
Date

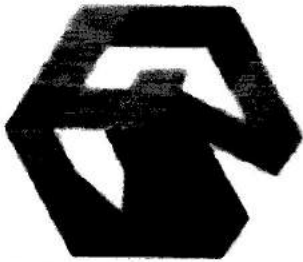
Signature



Gain Valuable solutionN

**24.07.2018
Chennai**

TO WHOM IT MAY CONCERN

This is to certify that **Mr. Hem Prashanth .K.C, Student of III yr.**, Department of Information Technology, B.S. Adbur Rahman Crescent Institute of Science and Technology, Chennai, Tamilnadu has successfully completed the internship programme in **Testing of Web Applications** at **Gain Valuable solutionN** from 18/06/2018 to 07/07/2018. During the period of his internship programme with us, he was found punctual, hardworking and inquisitive.

We wish him every success in his life.

For, Gain Valuable solutionN.

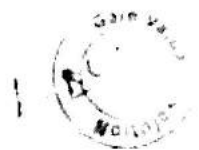

Authorized Signatory

No: 164/G4, Nisha Plaza, Karuneeagar Street, Adambakkam, Chennai – 600088
9841615418 www.gvnsolutions.com
gainvaluableolution@gmail.com

INTERNSHIP LETTER

A Jasima Beagum studying IV year B.Tech in Information Technology at B.S.Abdur Rahman Crescent Institute of Science and Technology will be undergoing internship program at Smartron India Private Limited for duration of 4 months from January 2018 to April 2018.

Sincerely,

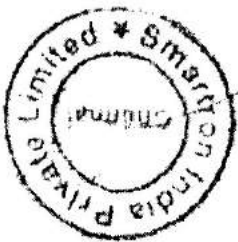

Shuveb Hussain

Vice President Of Engineering (tronX)

Smartron India private Limited,

Telephone: +91 - 9840380386

Email : shuveb.hussain@smartron.com

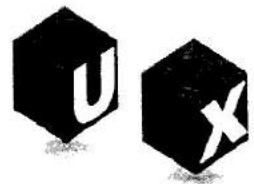

F E E L G

Date: 10 January 2018

BONAFIDE CERTIFICATE
TO WHOM IT MAY CONCERN

This is to certify that Mr/Ms. Matheen Fathima , Final Year ,B.Tech IT Engineering Graduate from B.S.A Crescent Institute of Science and Technology- Chennai is undergoing an internship program and doing her project in the domain IoT and Wireless Communication with UX Business Solutions Pvt. Ltd from December 2017 till May 2018.

This is a non-paid internship with no stipend and commercial commitments from our end. This internship is related to an educational purpose only

This certification is being issued upon his/her request for whatever purpose it may serve.

For: UX Business Solutions Private Limited

S. Deepika
Deepikka
Head - IoT initiatives



UX Business Solutions Private Limited

7&7A-3rd Floor - Wellington Estate 53, Ethiraj Salai (Opp - Ethiraj College)
Egmore, Chennai - 600 008, INDIA

+91 44 48585185 ✉ info@uxbusinesssolutions.com 🌐 www.uxbusinesssolutions.com

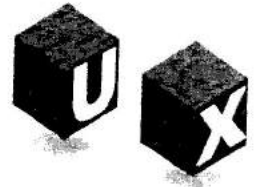

F E E L G

Date: 10 January 2018

BONAFIDE CERTIFICATE

TO WHOM IT MAY CONCERN

This is to certify that Mr/Ms. Moghal Muzammil Banu, Final Year, B.Tech IT Engineering Graduate from B.S.A Crescent Institute of Science and Technology- Chennai is undergoing an internship program and doing her project in the domain IoT and Wireless Communication with UX Business Solutions Pvt. Ltd from December 2017 till May 2018.

This is a non-paid internship with no stipend and commercial commitments from our end. This internship is related to an educational purpose only

This certification is being issued upon his/her request for whatever purpose it may serve.

For: UX Business Solutions Private Limited

S. Deepikaa S
Deepikaa S
Head - IoT initiatives



UX Business Solutions Private Limited

7&7A-3rd Floor - Wellington Estate 53, Ethiraj Salai (Opp - Ethiraj College)
Egmore, Chennai - 600 008, INDIA

+91 44 48585185 ✉ info@uxbusinesssolutions.com 🌐 www.uxbusinesssolutions.com



NEWGEN

Newgen Software Technologies Limited

CIN: L72200DL1992PLC049074

D-162, Okhla Phase-I, New Delhi-110 020, INDIA

Tel: (+91)-11-40773700, 26815467, 26815469, Fax: (+91)-11-26815472,

Email: corpmtg@newgensoft.com URL: <https://newgensoft.com>

Ref. No: 2381

February 19, 2019

Mr. Sabareesh M
H.No. G-2, B-Block,
Vijayalakshmi Apartments,
Puzhuthivakkam, Kancheepuram,
Tamil Nadu-600091

Sub: - Offer Letter For Internship

Dear Mr. Sabareesh,

Congratulations! We are pleased to inform you that you are one of the chosen few who have proven their worth in 'NEW...GENESIS' - our Campus Engagement Program.

We have accelerated our ambitions to achieve leadership position as a formidable player in the established and in the emerging verticals across the globe. We stand at the threshold of a new era of business opportunity that will completely alter the course of the destiny of Newgen and Newgenites. You will have the opportunity to be part of the growth engine which will fuel the zeal to deliver world class productized software solutions in the business domains of today and tomorrow.

With this, we extend the opportunity to complete your final semester project internship with us. During the internship period you will be designated as **Software Engineer (T)** and will be paid a stipend of ₹ 7500/- per month. By the end of the successful completion of your internship, you will be appointed as a Software Engineer in the month of July 2019 and detailed employment letter will be issued to you.

You are required to report for your internship on **February 25, 2019** at Plot No-13, D 17, SIPCOT IT Park, Siruseri, Navalur, Chennai-603103.

During this period, you are required to abide by the terms & conditions annexed here to.

We wish you a long and rewarding career with us.

For Newgen Software Technologies Limited

(Surender Jeet Raj)
Senior Vice President-HRD



INTERNSHIP APPOINTMENT CONFIRMATION

07/06/2018
Chennai

Susan Khanum
Student, Final Year, Information Technology
B.S.A Crescent Institute of Science and Technology
Chennai

Dear Susan Khanum

Please consider this letter a confirmation of internship in the Immigration Project for the client called Transcripts Guru effective June 11, 2018 through June 30, 2018 for 40 hours per week at no compensation

This appointment has been recommended by your university results and your academic excellence witnessed by your college/university staff. On the basis that you will perform development of application, testing and deployment. In performing these duties you will be responsible to deliver and you should direct any inquiries to Vigneswaran Paramathayalan, Chair-Cloud Bull India Operations

Cloud Bull will be able to reimburse you for travel and accommodation expenses up to a maximum of \$350 per day if in case of international travel. We will need original receipts for these charges. Please provide us with proof of medical insurance and a photocopy of your passport and visa.

If in case we shortlist you for an international travel, Cloud Bull will provide you with forms to apply for a B1 visa to US at your nearest United States Embassy or Consular Office.

Upon arrival to campus, contact Vigneswaran Paramathayalan

Please indicate in the space provided below whether you accept this confirmation of this internship and return it to me as soon as possible. The duplicate of this letter is for your personal file. *(Please note that you are receiving two original copies of this letter. You will need the second original when you apply for your visa at the United States Embassy.)*

We appreciate your interest in volunteering for internship and welcome your contribution to Cloud Bull India

Sincerely,

VIGNESWARAN PARAMATHAYALAN

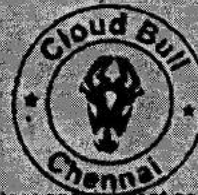

I hereby accept the above offer of volunteer appointment as stated above.
(accept/decline)

11/06/2018
Date

Signature



ZOHO Corporation Private Limited

Estancia IT Park, Plot No. 140, 151,
Vallanchery Village, Chengalpet Taluk,
Kancheepuram District - 603 202 Tamilnadu.
Ph: +91- 44 - 6744 7070, Fax: +91 - 44 - 2270 7172
www.zohocorp.com

January 11th, 2018

To whom so ever it may concern

This is to certify that Ms. Syed Oli Fathima (140081601043), B.Tech IT (2014-2018) of Crescent University, is hereby doing an internship at Zoho Corporation in the iOS domain working on Mobile Application Development, from January 8, 2018 to June 2018.

Sohail M I

(Manager – HR)





January 11th, 2018

To whom so ever it may concern

This is to certify that Ms. Ulfath Thabassum (140081601046), B.Tech IT (2014-2018) of Crescent University, is hereby doing an internship at Zoho Corporation in the iOS domain working on Mobile Application Development, from January 8, 2018 to June 2018.

M. J. Sohan

Sohail M I

(Manager - HR)





F E E L IT

Date: 10 January 2018

BONAFIDE CERTIFICATE

TO WHOM IT MAY CONCERN

This is to certify that Mr/Ms. Matheen Fathima , Final Year ,B.Tech IT Engineering Graduate from B.S.A Crescent Institute of Science and Technology- Chennai is undergoing an internship program and doing her project in the domain IoT and Wireless Communication with UX Business Solutions Pvt. Ltd from December 2017 till May 2018.

This is a non-paid internship with no stipend and commercial commitments from our end. This internship is related to an educational purpose only

This certification is being issued upon his/her request for whatever purpose it may serve.

For: UX Business Solutions Private Limited

S. Deep
Deepikaa
Head - IoT initiatives

UX Business Solutions Private Limited

7&7A-3rd Floor - Wellington Estate 53, Ethiraj Salai (Opp - Ethiraj College)
Egmore, Chennai - 600 008, INDIA

+91 44 48585185 ✉ info@uxbusinesssolutions.com 🌐 www.uxbusinesssolutions.com

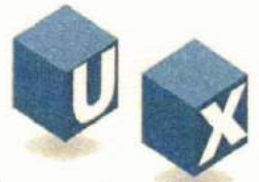

F E E L IT

Date: 10 January 2018

BONAFIDE CERTIFICATE

TO WHOM IT MAY CONCERN

This is to certify that Mr/Ms. Moghal Muzammil Banu, Final Year, B.Tech IT Engineering Graduate from B.S.A Crescent Institute of Science and Technology- Chennai is undergoing an internship program and doing her project in the domain IoT and Wireless Communication with UX Business Solutions Pvt. Ltd from December 2017 till May 2018.

This is a non-paid internship with no stipend and commercial commitments from our end. This internship is related to an educational purpose only

This certification is being issued upon his/her request for whatever purpose it may serve.

For: UX Business Solutions Private Limited

S. Deepika
Deepikka S
Head - IoT initiatives



UX Business Solutions Private Limited

7&7A-3rd Floor - Wellington Estate 53, Ethiraj Salai (Opp - Ethiraj College)
Egmore, Chennai - 600 008, INDIA

+91 44 48585185 ✉ info@uxbusinesssolutions.com 🌐 www.uxbusinesssolutions.com



UNITED INDIA INSURANCE COMPANY LIMITED
No.58, Purasawalkam High Road,
Chennai 600 007.

Ref No:010900/2018
06.3.2018

To
Dr. S. Rajasekaran,
Professor & Head,
Dept. Of Mathematics & Actuarial Science,
B.S Abdul Rahman Crescent Inst. Of Science & Technology,
Vandalur, Chennai 48.

Sr.

Re: Project training to your student - Mr. shaik ijaz.s

This is to certify that Mr. shaik ijaz.s pursuing M.Sc. Actuarial Science in **B.S.ABDUR RAHMAN CRESCENT INSTITUTE OF SCIENCE AND TECHNOLOGY**, Vandalur, Chennai-48 has undergone project training in our organization from 7.2.2018 to 16.3.2018 in Claims and Underwriting Departments. During his training period, he has learnt the nuances of General Insurance Claims and Underwriting systems under the guidance of the team of our officers. During his training period his conduct and character was good.

Thank You,

UNITED INDIA INSURANCE CO.LTD

SR.DIVISIONAL MANAGER



UNITED INDIA INSURANCE COMPANY LIMITED

**No.58, Purasawalkam High Road,
Chennai 600 007.**

Ref No: 010300/2018

30.1.2018

To
Dr. S. Rajasekaran,
Professor & Head,
Dept. Of Mathematics & Actuarial Science,
B.S. Abdur Rahman Crescent Inst. Of Science & Technology,
Vandalur, Chennai 48.

Re: Project training to your student – Ms. Nivethitha.V.R

This is to certify that Ms. Nivethitha.V.R pursuing M.Sc. Actuarial Science in B.S.ABDUR RAHMAN CRESCENT INSTITUTE OF SCIENCE AND TECHNOLOGY, Vandalur, Chennai-48 has undergone project training in our organization from 1.2.2018 to 28.2.2018 in Claims and Underwriting Departments. During her training period, she has learnt the nuances of General Insurance Claims and Underwriting systems under the guidance of the team of our officers. During her training period her conduct and character was good.

Thank You,

UNITED INDIA INSURANCE CO.LTD

D.O. No. 010300

K. S. Sud

SUBDIVISIONAL MANAGER





UNITED INDIA INSURANCE COMPANY LIMITED
No.58, Purasawalkam High Road,
Chennai 600 007.

Ref No.010300/2018
28.2.2018

To
Dr. S. Rajasekaran,
Professor & Head,
Dept. Of Mathematics & Actuarial Science,
B.S Abdur Rahman Crescent Inst. Of Science & Technology,
Vandalur, Chennai 48.

Sir,

Re: Project training to your student – Mr. Anikumar.T.R

This is to certify that Mr. Anikumar.T.R pursuing M.Sc. Actuarial Science in B.S.ABDUR RAHMAN CRESCENT INSTITUTE OF SCIENCE AND TECHNOLOGY, Vandalur, Chennai-48 has undergone project training in our organization from 1.2.2018 to 28.2.2018 in Claims and Underwriting Departments. During his training period, he has learnt the nuances of General Insurance Claims and Underwriting systems under the guidance of the team of our officers. During his training period his conduct and character was good.

Thank You,

UNITED INDIA INSURANCE CO.LTD

D.O. No. 010300

L. S. S. S.

REGIONAL DIVISIONAL MANAGER





UNITED INDIA INSURANCE COMPANY LIMITED
No.58, Purasawalkam High Road,
Chennai 600 007.

Ref No.010300/2018
28.2.2018

To
Dr. S. Rajasekaran,
Professor & Head,
Dept. Of Mathematics & Actuarial Science,
B.S Abdur Rahman Crescent Inst. Of Science & Technology,
Vandalur, Chennai 48.

Sr.

Re: Project training to your student – Mr. Anikumar.T.R

This is to certify that Mr. Anikumar.T.R pursuing M.Sc. Actuarial Science in B.S.ABDUR RAHMAN CRESCENT INSTITUTE OF SCIENCE AND TECHNOLOGY, Vandalur, Chennai-48 has undergone project training in our organization from 1.2.2018 to 28.2.2018 in Claims and Underwriting Departments. During his training period, he has learnt the nuances of General Insurance Claims and Underwriting systems under the guidance of the team of our officers. During his training period his conduct and character was good.

Thank You,

UNITED INDIA INSURANCE CO.LTD

D.O. No. 010300

L. S. S.

REGIONAL DIVISIONAL MANAGER





UNITED INDIA INSURANCE COMPANY LIMITED
No.58, Purasawalkam High Road,
Chennai 600 007.

18/02/2018
20.02.2018

To,
Dr. S. Rajasekaran,
Professor & Head,
Dept. Of Mathematics & Actuarial Science,
B.S. Abdur Rahman Crescent Inst. Of Science & Technology,
Vandalur, Chennai 48.

Re: Project training to your student – Ms. Ayana Joseph

This is to certify that Ms. Ayana Joseph pursuing M.Sc. Actuarial Science in B.S.ABDUR RAHMAN CRESCENT INSTITUTE OF SCIENCE AND TECHNOLOGY, Vandalur, Chennai-48 has undergone project training in our organization from 1.2.2018 to 28.2.2018 in Claims and Underwriting Departments. During her training period, she has learnt the nuances of General Insurance Claims and Underwriting systems under the guidance of the team of our officers. During her training period her conduct and character was good.

UNITED INDIA INSURANCE CO.LTD

D.O. No. 010300

Handwritten signature

REGIONAL MANAGER





MTAB Engineers Pvt. Ltd.
Electrical & Electronics I.E.,
Perungudi,
Chennai - 600096.
Tamilnadu, India.
Ph: (+91-44) 24960751/52/53
Fax: (+91-44) 24960584

HR/MTAB/2017
Thursday, July 13, 2017

TO WHOMSOEVER IT MAY CONCERN

This is to certify that **Mr. SASITHARAN. S (161212601009)**, a student of second year **M.TECH (Manufacturing Engineering)** from **B.S.A Crescent University, Vandalur, Chennai-48**, has completed **INTERNSHIP** program at **MTAB Engineers Pvt Ltd** during the period from **26.06.2017 to 10.07.2017**.

During the above training period, his character and conduct were **excellent**.

We wish him all success in his feature endeavor.

For **MTAB Engineers Private Limited**,

A.Soma Sundaram

Factory HR Manager

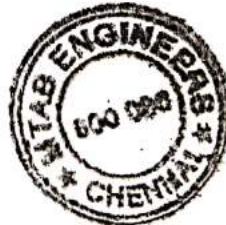

Office : 13, Mangal Bazaar Road, Laxmi Nagar, New Delhi - 110092



MTAB Engineers Pvt. Ltd.
Electrical & Electronics I.E.
Perungudi,
Chennai - 600096.
Tamilnadu, India.
Ph: (+91-44) 24960751/52/53
Fax: (+91-44) 24960584

HR/MTAB/2017
Thursday, July 13, 2017

TO WHOMSOEVER IT MAY CONCERN

This is to certify that Mr. SARAVANAN. K (161212601006), a student of second year M.TECH (Manufacturing Engineering) from B.S.A Crescent University, Vandalur, Chennai-48, has completed INTERNSHIP program at MTAB Engineers Pvt Ltd during the period from 26.06.2017 to 10.07.2017.

During the above training period, his character and conduct were excellent.

We wish him all success in his feature endeavor.

For MTAB Engineers Private Limited,

A.Soma Sundaram

Factory HR Manager



Regd. Office : 13, Mangal Bazaar Road. Laxmi Nagar, New Delhi - 110092

MTAB

MTAB Engineers Pvt. Ltd.
Electrical & Electronics I.E,
Perungudi,
Chennai - 600096.
Tamilnadu, India.
Ph: (+91-44) 24960751/52/53
Fax: (+91-44) 24960584

HR/MTAB/2017

Thursday, July 13, 2017

TO WHOMSOEVER IT MAY CONCERN

This is to certify that **Mr. MANIRAJ. D (161212601002)**, a student of second year **M.TECH (Manufacturing Engineering)** from **B.S.A Crescent University, Vandalur, Chennai-48**, has completed **INTERNSHIP** program at **MTAB Engineers Pvt Ltd** during the period from **26.06.2017 to 10.07.2017**.

During the above training period, his character and conduct were **excellent**.

We wish him all success in his feature endeavor.

For **MTAB Engineers Private Limited**,



A.Soma Sundaram

Factory HR Manager

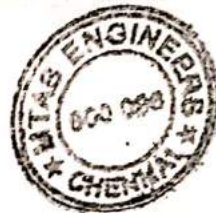

Regd. Office : 13, Mangal Bazaar Road, Laxmi Nagar, New Delhi - 110092



AABONSMIT ALLOYS P. LTD.,

Registered Office: 'Menumas' W-550, Anna Nagar West. Chennai – 6000101. Tamilnadu, India.

Tel : +91-44-26150039, Fax : 26155579 E-mail : admin@aabonsmit.com

Technical collaboration with CARBO WELD SCHWEISSMATERIALIEN GMBH

ZE/ASL/2017

dt-16.07.2017

TO WHOMSOEVER IT MAY CONCERN

This is to certify that **Mr. Zavith Nazar. Z (161212601010)**, a student of second year **M.Tech (Manufacturing Engineering)** from **BSA Crescent University, Vandalur, Chennai-48**, was in our organisation as an **INTERN** from **01.07.17 to 15.07.2017**. During the period of his internship program with us he was found punctual, hardworking and inquisitive.

We wish him every success in life.

For **AABONSMIT ALLOYS PVT.LTD,**

V.Venkatesh

Zonal Engineer



AABON GmbH CMF produkte Harz GERMANY
Manufacturing Facilities & Central Distribution Centre :



AABONSMIT ALLOYS P. LTD.,

Registered Office: 'Menumas' W-550, Anna Nagar West, Chennai - 6000101, Tamilnadu, India
Tel: +91-44-26150039, Fax: 26155579 E-mail: admin@aabonsmit.com
Technical collaboration with CARBO WELD SCHWEISSMATERIALIEN GMBH

ZE/ASL/2017

dt-16.07.2017

TO WHOMSOEVER IT MAY CONCERN

This is to certify that **Mr. Sahabudeen. K (161212601008)**, a student of second year **M.Tech (Manufacturing Engineering)** from **BSA Crescent University, Vandalur, Chennai-48**, was in our organisation as an **INTERN** from **01.07.17 to 15.07.2017**. During the period of his internship program with us he was found punctual, hardworking and inquisitive.

We wish him every success in life.

For AABONSMIT ALLOYS PVT.LTD,

V.Venkatesh

Zonal Engineer



AABON GmbH CMF produkte Harz GERMANY
Manufacturing Facilities & Central Distribution Centre :
CMF FORSTISV - I, #277/2 & 277/3 NH5, Neduvarambakkam, Chennai- 600067, India
www.aabonsmit.com



AABONSMIT ALLOYS P. LTD.,

Registered Office: 'Menumas' W-550, Anna Nagar West Chennai – 6000101, Tamilnadu, India.
Tel : +91-44-26150039, Fax : 26155579 E-mail : admin@aabonsmit.com
Technical collaboration with CARBO WELD SCHWEISSMATERIALIEN GMBH

ZE/ASL/2017

dt-16.07.2017

TO WHOMSOEVER IT MAY CONCERN

This is to certify that **Mr. Sudharson. R (161212601007)**, a student of second year **M.Tech (Manufacturing Engineering)** from **BSA Crescent University, Vandalur, Chennai-48**, was in our organisation as an **INTERN** from **01.07.17 to 15.07.2017**. During the period of his internship program with us he was found punctual, hardworking and inquisitive.

We wish him every success in life.

For **AABONSMIT ALLOYS PVT.LTD,**

V. Venkatesh

V.Venkatesh

Zonal Engineer



AABON GmbH CMF produkte Harz GERMANY
Manufacturing Facilities & Central Distribution Centre :

CMF FORSTISV – I, #277/2 & 277/3, NH5, Neduvarambakkam, Chennai- 600067, India
www.aabonsmit.com



INDIAN INSTITUTE OF INFORMATION TECHNOLOGY
DESIGN AND MANUFACTURING, KANCHEEPURAM
CHENNAI-600127

MHRD Teaching Learning Centre for Design & Manufacturing Education

Certificate of Internship

This is to certify that Mr/Ms MOHAMED USAID HAMMAD K of
B.S ABDOU RAHMAN CRESCENT INSTITUTE OF SCIENCE & TECHNOLOGY has completed the
internship on CNC BASED PCB MILLING MACHINE during Feb - April, 2018
in the Teaching Learning Centre at our institute.

MHRD Teaching Learning Centre,
For Design and Manufacturing Education
Indian Institute of Information Technology,
Design and Manufacturing, Kancheepuram
Metturattai, Chennai - 600 127.

Dr. S. R. Pandian
Coordinator & Dean (Planning)



CREATING WEALTH FOR WELLBEING

NLC India Limited

(formerly - Neyveli Lignite Corporation Ltd.,) "NAVRATNA" - Govt. of India Enterprise

LEARNING & DEVELOPMENT CENTRE



CERTIFICATE FOR INPLANT TRAINING

This is to certify that Mr/Ms SYED MOHAMMAD SALMAN HABIB, III B.TECH. (MECH)

..... B.S.A.R.CRESCENT INSTITUTE OF SCIENCE AND TECHNOLOGY, CHENNAI has undergone

Inplant Training in **NLC India Limited, Neyveli** between 25-Jun-18

and 30-Jun-18

NLCIL wishes him / her Success in all future endeavours.



HEAD / L&D
LEARNING & DEVELOPMENT CENTRE

"Training adding Value to Life"

Jayaraj Trucking

Jayaraj Trucks & Buses Pvt. Ltd.
(BharatBenz Authorised Dealer)
Nagercoil Main Road, Ayankulam Bus Stop,
Opp. Rose Mary College, Tirunelveli - 627 007.
Phone : 0462-6532211, 92444 22100
Toll free number : 1800 3002 7057
E-mail : ash.tvl@jayarajtrucking.com, info@jayarajgroup.com



Certificate of Excellency

This is to certify that Mr. M.JUNAITH KHAN , student of B.S.ABDUR RAHMAN CRESCENT INSTITUTE OF SCIENCE AND TECHNOLOGY, CHENNAI-600048, of MECHANICAL ENGINEERING branch , RRN-150021601065 . Have completed his internship of 8th semester of 30 days i.e, the period of. 10.01.2019 to 09.02.2019 under my guidance.

I have found him to be a self-starter who is motivated, duty bound and Hard working. He performed excellent with well behaviour and he was punctual at time to report regularly. He worked sincerely on his assignments and his performance was PAR EXCELLENCE



[Handwritten Signature]
Authorised Signatory



CREDO SYSTEMZ
TRAINING & DEVELOPMENT

PRIMAVERA

ORACLE

Certificate of Excellence



This is to certify that

Syed Jaffer Sadiq I

Candidate ID : CRPRM5827

has successfully completed

Primavera P6 (Professional & Advanced) Training

course conducted during Mar 2017 - Apr 2017

Date: 09-04-2017

Authorized Signatory



ASHOK LEYLAND

Ennore, Chennai-57.

CERT No. HRD/T & D 086

Date: 10/01/17

CERTIFICATE

This is to Certify that Mr./Ms. A. B. MOHAMED ASLAM NOORANJ
Student of B. S. ABDUR RAHMAN UNIVERSITY was
offered In-plant training from 03/01/17 to 07/01/17 at
ASHOK LEYLAND LTD, Ennore, Chennai - 600 057.

DETAILS OF TRAINING ATTENDED

SL.No.	Department	Period of Exposure
1.	ENGINE ASSY	From: 03/01/17 To: 07/01/17
2.	GEAR BOX ASSY	
3.	CHASSIS ASSY	
4.	AXLE ASSY	
5.	ENGINE COMPONENTS	



For ASHOK LEYLAND LTD.,

Name : K. BALAJI

Signature : *K. Balaji*

Designation : MANAGER [L&D]

Assessments

1. Attendance

No. of days available - 05 DAYS

No. of days attended - 05 DAYS

2. Punctuality - GOOD

3. Interest - GOOD

4. Conduct - GOOD

5. General Remarks - NIL



ASHOK LEYLAND

Ennore, Chennai-57.

CERT No. HRD/T & D 086

Date : 10/01/17

CERTIFICATE

This is to Certify that Mr./Ms. A. B. MOHAMED ASLAM NOORAN J
Student of B. S. ABDUR RAHMAN UNIVERSITY was
offered In-plant training from 03/01/17 to 07/01/17 at
ASHOK LEYLAND LTD, Ennore, Chennai - 600 057.

DETAILS OF TRAINING ATTENDED

SL.No.	Department	Period of Exposure
1.	ENGINE ASSY	From : 03/01/17 To : 07/01/17
2.	GEAR BOX ASSY	
3.	CHASSIS ASSY	
4.	AXLE ASSY	
5.	ENGINE COMPONENTS	



For ASHOK LEYLAND LTD.,

Name : K. BALAJI

Signature : *K. Balaji*

Designation : MANAGER [L&D]

Assessments

1. Attendance

No. of days available - 05 DAYS

No. of days attended - 05 DAYS

2. Punctuality - GOOD

3. Interest - GOOD

4. Conduct - GOOD

5. General Remarks - NIL



सवारी डिब्बा कारखाना, चेन्नै - 600 038
रेल मंत्रालय की एक उत्पादन इकाई

INTEGRAL COACH FACTORY, CHENNAI - 600 038

A Production Unit Under Ministry of Railways

(AN ISO: 9001, ISO:14001 AND BS : 18001 CERTIFIED PRODUCTION UNIT)



Sl.No. : M/388/2018

Date : 19.06.2018



This is to certify that Mr./Ms. M. JAYAKARAN

Regn.No. 16.00.216.010.64 Course B.TECH

Branch MELCHANICAL, II Year, Student of

B.S. Abdur Rahman Crescent Institute of Science and Technology,

has undergone Inplant Training from 11-06-2018 to 18-06-2018

at Integral Coach Factory.



[Handwritten Signature]

Principal
Technical Training Centre
ICF, Chennai-38

Jayaraj Trucking

Jayaraj Trucks & Buses Pvt. Ltd.
(BharatBenz Authorised Dealer)
Nagercoil Main Road, Ayankulam Bus Stop,
Opp. Rose Mary College, Tirunelveli - 627 007.
Phone : 0462-6532211, 92444 22100
Toll free number : 1800 3002 7057
E-mail : ash.tvf@jayarajtrucking.com, info@jayarajgroup.com



Certificate of Excellency

This is to certify, that Mr. P. KAJA MOHAMED ZAHID , student of B.S.ABDUR RAHMAN CRESCENT INSTITUTE OF SCIENCE AND TECHNOLOGY, CHENNAI-600048, of MECHANICAL ENGINEERING branch , RRN-150021601066 . Have completed his internship of 8th semester of 30 days i.e, the period of. 10.01.2019 to 09.02.2019 under my guidance.

I have found him to be a self-starter who is motivated, duty bound and Hard working. He performed excellent with well behaviour and he was punctual at time to report regularly. He worked sincerely on his assignments and his performance was PAR EXCELLENCE

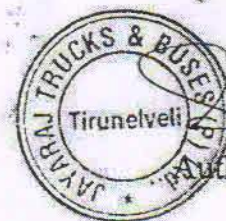

A handwritten signature in black ink, appearing to be "P. K. Zahid".

Authorised Signatory



INDIAN INSTITUTE OF INFORMATION TECHNOLOGY
DESIGN AND MANUFACTURING, KANCHEEPURAM
CHENNAI-600127

MHRD Teaching Learning Centre for Design & Manufacturing Education

Certificate of Internship

This is to certify that Mr/Ms MOHAMED USAID HAMMAD K of
B S ABDOU RAHMAN CRESCENT INSTITUTE OF SCIENCE & TECHNOLOGY has completed the
internship on CNC BASED PCB MILLING MACHINE during Feb - April, 2018
in the Teaching Learning Centre at our institute.

MHRD Teaching Learning Centre,
For Design and Manufacturing Education
Indian Institute of Information Technology,
Design and Manufacturing, Kancheepuram
Melsattayud, Chennai - 600127

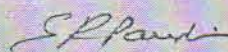
Dr. S. R. Pandian
Coordinator & Dean (Planning)

Brakes India Private Limited

Padi, Chennai 600 050

Telephone : (044) 2625 8161, 2652 6000

Fax : (044) 2625 7010, 2625 7844

Web : www.brakesindia.com

CIN : U35999TN1962PTC004928

Friday, December 14, 2018

C E R T I F I C A T E

This is to certify that **Mr A N Saravanan**, B.E (Mechanical)
Student of **Crescent Institute of Science & Technology -**
Chennai has done his '**Inplant Training**' in our Organization
from 10.12.2018 to 14.12.2018.

He has evinced keen interest in learning.

We wish him success in all his future endeavors.

N Lakshminarasimhan
General Manager – HR



2nd March, 2017

Dear N.T Roashan,

Subject: Offer Letter for Global Academic Internship Programme

Congratulations!

You have been selected for the Global Academic Internship Programme (GAIP) which is delivered with professors from two of the world's top 15 universities – National University of Singapore (NUS) and Nanyang Technological University (NTU) and industry partner – Hewlett Packard.

Global Academic Internship Programme (GAIP) is an opportunity for you to complete credit courses at world top 15 universities, work on industry projects and get global career insights. The entire programme is delivered in Singapore.

The key highlights of GAIP are:

1. Complete credit courses at world top-15 universities
2. Work on industry projects
3. Interact with world's top educators
4. Get global industry insights from senior leaders of top MNCs
5. Receive letter of evaluation from NTU/NUS faculty
6. Experience global industry trends through industry visits

Please find enclosed the programme and fee details.

Please note that your admission for GAIP will be confirmed only after payment of the programme fee (Rs 2,10,000) by **28th March, 2017**.

Best Wishes,
Aali Basant
Director
Corporate Gurukul



Executive Engineer and Administrative Officer,
Besant Nagar Division
Tamil Nadu Housing Board,
Adyar, Chennai-600020.
Phone No. : 044-24913561

CERTIFICATE

This is certifying that IRFHAN KHAN.H (RRN. 150011601038) studying (B.Tech Civil) in B.S.Abdur Rahman Crescent Institute of Science and Technology, Vandalur, Chennai – 48. has attended training period from 08.06.2018 to 07.07.2018, during the training period he is fully involved in preparation of Estimate, Construction and Supervision works.

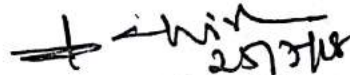
Exe.Engineer & Adm.Officer
Besant Nagar Division.

Executive Engineer &
Administrative Officer
Besant Nagar Division
Tamil Nadu Housing Board
Chennai-600 020.





Sree's Builders & Promoters

71, 3rd Main Road, Mogappair West, Nolambur, Chennai – 600 037
Mobile : 9841013988,

06.07.2018

This is to certify that **Mr. A. KALANIDHI RAJAH**, Regn. No.150011601039 studying at B.S.Abdur Rahman Crescent Institute of Science and Technology, Vandalur, Chennai – 600045 has attended training during the period from 04.06.2018 to 03.07.2018.

He has found to be good, punctual and observant during the training period.

For SREE'S
BUILDERS & PROMOTERS

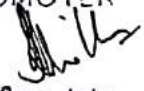
Proprietor



GS Constructions

Civil Engineer & Contractor

97104 09011

No.34/1, New No.12, Ujjini Street, Ayanavaram, Chennai - 600 023.

Email: manoharsree2@gmail.com

GSTIN : 33AYVPM8285C1ZX

Date : 13-07-18

CERTIFICATE

This is certify that **S.B. KALIL RAHAMN** (RRN.150011601040) studying in B.S.Abdur Rahman Crescent Insitute of Science and Technology, Vandalur, Chennai – 48 has attended training during the period from **11-06-2018 to 10-07-2018** . during the training period he is fully involved in public building (e.g.) Chennai. .

For G.S.Constructions

For GS Constructions

Proprietor

GSTIN: 33ABDPU0590R1Z3
NO: ABDPU0590R
9443497163
PH: 04630-255014
EMAIL: allogu00@gmail.com

A. ULAGU LAKSHMANAN
CLASS I Contractor
Highways & PWD

22/54, ArasalwarKoli West Street, Sriaikuntam -628601, Thoothukudi Dt.

CERTIFICATE

This is certify that A.MUSTAQ AHAMED (RRN. 150011601124) studying in B.S.Abdur Rahman Crescent Institute of Science and Technology, Vandalur, Chennai – 48 has attended training during the period from 18.06.2018 to 10.07.2018 During the training period he is fully involved in preparation of Construction and Supervision works.

A. ULAGU LAKSHMANAN, D.C.E.
CONTRACTOR
22, ARASALWAR KOVIL STREET
SRIVAIKUNTAM-628 601



J/HRIR/291/18

Date- 13.07.2018

TO WHOM IT MAY CONCERN

This is to certify that, **MOHAMMAD MADNI**, a student of **B.Tech (CIVIL)**, of **CRESCENT INSTITUTE OF SCIENCE & TECHNOLOGY**, has successfully completed the Internship & project entitled "**PLASTIC ROAD**" from **21th JUNE'18 to 13th JULY'2018**.

The project report was submitted to JUSCO and it was found good. During his Internship, he was found to be very hardworking, dedicated and disciplined.

We wish him the best for the future.

D.K. SINGH,

Manager, Training

Jamshedpur Utilities & Services Company Limited
Sakchi Boulevard Road, Northern Town Bistupur Jamshedpur 831 001 India
Tel 91 657 2431914 Fax 91 657 2424219
Website : www.juscoltd.com
CIN : U45200JH2003PLC010315

A TATA Enterprise

Scanned by CamScanner

S K M. Periyakaruppan
Building Constructor



CERTIFICATE

This is certify that MOHAMED RILUVANN (RRN. 150011601126) studying in
B.S.Abdur Rahman Crescent Insitute of Science and Technology, Vandalur, Chennai -48
has attended training during the period from 04/06/2018 to 09/07/2018.
during the training period he is fully involved in preparation of SITE ENGINEERING.

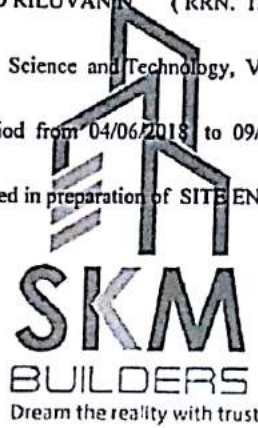

For SKM BUILDERS
Signature / With Seal
PROPRIETOR

Address: 275, S.K.M. complex, TT nagar 1st steet, Sekkalai Road, Karaikudi-630002

Mob: +91 - 94431 37972 - 95007 98007

Email: skmperi@yahoo.com

Website: www.skmbuilders.in



BHARAT BUILDERS

07-07-2018

CERTIFICATE

This is certify that Mr. Mohammed Ashtak Nabil (RRN.) 150011601127 studying in B.S. Abdur Rahiman Crescent Institute of Science and Technology, Vandalur, Chennai - 48 has attended training during the period from 04-06-2018 to 06-07-2018 during the training period he is fully involved in Execution of Construction Activities.

Signature / With seal



VASANTH PLANNERS & DESIGNERS

Er.K.BABU, B.E., M.Sc., (Valuation)
Er.K.VIJAYABANU, M.Tech., MBA., M.Sc., (Valuation)
Licenced Building Surveyors

Office :

#13-V.C.M. Street, K.V.S.Complex (1st Floor)

(Opp.to New Bus Stand)

Tirupattur - 635 601. Vellore Dist.

Cell : 94862 81975, 94869 66002, 94868 49126

Ph : 04179 - 221975

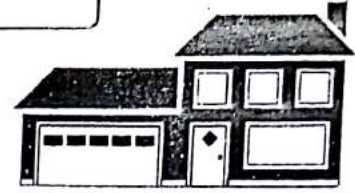

We Undertake : Building Plans, Designs, Estimates, Lay - Out, Supervisings etc...
(All are done in computer as per the Vasthu Sashtira)

CERTIFICATE

This is to certify that **MOHAMMED RAIYAN K A** (RRN: 150011601130) studying in B. S. Abdur Rahman Crescent Institute of Science and Technology, Vandalur, Chennai – 48 has attended training during the period from 06/06/2018 to 08/07/2018. During the training period he is fully involved in

AutoCad drawing work.

Er. K. VIJAYA BANU
M.Tech.,MBA.,M.Sc.(Valuation)
Licenced Civil Engineer & Valuer
Vasanth Planners & Designers
13-E, V.C.M. Street, 1st Floor,
(Near Bus Stand)
TIRUPATTUR-635 601. Vellore Dt.
Cell: 94869 66002, 94862 81975
Signature / With seal

04.11.2018

This is to certify that **Mr. MOHAMMED SAHIB THAMBI M.M**, Regn. No. 150011601131
studying at **B. S. Abdur Rahman Crescent Institute of Science and Technology, Vandalur, Chennai – 600**
048 has attended training during the period from **11.06.2018 to 25.06.2018**

He has found to be good, punctual and observant during training period.

SMART CONSTRUCTION
95/B, Kuthukal Street
KAYALPATNAM - 628 204
Cell: +918778212982

F. Mohan Anand
Signature with Seal



Executive Engineer and Administrative Officer,
Besant Nagar Division
Tamil Nadu Housing Board,
Adyar, Chennai-600020.
Phone No. : 044-24913561

CERTIFICATE

This is certifying that MUHAMMED AFROSE.J (RRN. 150011601033) studying (B.Tech Civil) in B.S.Abdur Rahman Crescent Institute of Science and Technology, Vandalur, Chennai – 48. has attended training period from 08.06.2018 to 07.07.2018, during the training period he is fully involved in preparation of Estimate, Construction and Supervision works.



Exe.Engineer & Adm.Officer
Besant Nagar Division.
Executive Engineer &
Administrative Officer
Besant Nagar Division
Tamil Nadu Housing Board
Chennai-600 020.



S M BUILDERS & PROMOTERS PRIVATE LIMITED

CERTIFICATE

This is certify that M.ABDUL KHADER ILAHEE (RRN. 150011602001) studying in B.S.Abdur Rahman Crescent Insitute of Science and Technology, Vandalur,Chennai – 48 has attended training during the period from 03.05.2018 to 13.07.2018 during the training period he is fully involved in preparation of Site Execution and Quality Control

For S.M. BUILDERS & PROMOTERS PVT. LTD.

Director

Regd. Off : 34-Griffiths Street, Pallavaram, Chennai - 43.
Ph : 044-22642275 Cell : 97908 37583, 98843 43637
Web Site : www.smbuilderspromoters.com E-mail : smbuilderspromoters@gmail.com

Buhari Builders & Contractors P Ltd



BBC

Imagine! We Make

CERTIFICATE

Date : 20.07.2018

This is certify that M. ABDUL KHADER ILAHEE (RRN.150011602001) studying in B.S.Abdur Rahman Crescent Insitute of Science and Technology, Vandalur,Chennai – 48 has attended training during the period from 01.03.2018 to 20.07.2018, during the training period he is fully involved in preparation of **Site execution and Quality Control.**

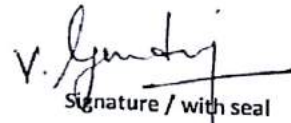
Signature / with seal

For BUHARI BUILDERS &
CONTRACTORS (P) LTD.

3rd Floor, Buhari Building, 4 Moores Road, Chennai-600 006
Phone: +91 44 42261100, E mail-bip@buhariholding.com
www.bhari.co.in

Buhari Builders & Contractors P Ltd



BBC

Imagine! We Make

CERTIFICATE

Date : 20.07.2018

This is certify that M. MOHAMED RIYAS (RRN.150011602006) studying in B.S.Abdur Rahman Crescent Insitute of Science and Technology, Vandalur,Chennai -48 has attended training during the period from 01.03.2018 to 20.07.2018 during the training period he is fully involved in preparation of Site execution and Quality Control.

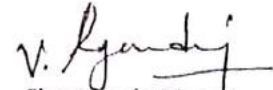
Signature / with seal

FOR BUHARI BUILDERS &
CONTRACTORS (P) LTD.

3rd Floor, Buhari Building, 4 Moores Road, Chennai-600 006
Phone: +91 44 42261100, E mail-bip@buhariholding.com
www.bhari.co.in



S M BUILDERS & PROMOTERS PRIVATE LIMITED

CERTIFICATE

This is certify that M.MOHAMED RIYAS (RRN. 150011602006) studying in B.S.Abdur Rahman Crescent Insitute of Science and Technology, Vandalur,Chennai – 48 has attended training during the period from 03.05.2018 to 13.07.2018 during the training period he is fully involved in preparation of Site Execution and Quality Control

For S.M. BUILDERS & PROMOTERS PVT. LTD.

Director

Regd. Off : 34-Griffiths Street, Pallavaram, Chennai 43.
Ph : 044-22642275 Cell : 97908 37583, 98843 43637
Web Site : www.smbuilderspromoters.com E-mail : smbuilderspromoters@gmail.com

AL-ALIF Builders & Promoters

Jasmin Garden,
Vattipillayar Kovil Street,
Kumbakonam-612 001.

Cell: 9944994965

Cell: 9940961017

Date: 5.11.2018....

INTRENSHIP CERTIFICATE

This is to certify that **Mr. J. MARTIN JEEVA ANAND**,
S/o.R. JOHNSON, a student of **B.Tech., (Civil Engineering)**,
B.S. ABDUR RAHMAN CRESCENT INSTITUTE OF SCIENCE
AND TECHNOLOGY, VANDALUR, CHENNAI has successfully
completed **1 Month (from 1st September 2018 to 30th September**
2018) long **Internship Programme** with us.

He was found Punctual, Hard Working and Inquisitive.

We wish him every success in life.

AL-ALIF Builders & Promoters
Partner

Partner

AL-ALIF Builders & Promoters

Jasmin Garden,
Vattipillayar Kovil Street,
Kumbakonam-612 001.

Cell: 9944994965

Cell: 9940961017

Date: 5.11.2018.....

INTRENSHIP CERTIFICATE

This is to certify that **Mr. P. MOHAMED SUHAIL**,
S/o.PACKIR MOHAMMED, a student of **B.Tech.**, (Civil
Engineering), **B. S. ABDUR RAHMAN CRESCENT INSTITUTE
OF SCIENCE AND TECHNOLOGY, VANDALUR, CHENNAI**
has successfully completed **Internship Programme** with us from the
period of **1st July 2018 to 20th July 2018.**

He was found Punctual, Hard Working and Inquisitive.

We wish him every success in life.

AL-ALIF Builders & Promoters

S. Partner

M. Partner

S.K.M. Periyakaruppan
Building Constructor



CERTIFICATE

This is certify that ASRARUL AQIF P. (ERN 150011601021) studying in
B.S. Abdur Rahman Crescent Insitute of Science and Technology, Mandalur, Chennai-48.
has attended training during the period from 04/06/2018 to 09/07/2018.
during the training period he is fully involved in preparation of SITE ENGINEERING.



For SKM BUILDERS

Signature / With seal

PROPRIETOR/

Address: 275, S.K.M. complex, TT nagar 1st steet, Sekkalai Road, Karaikudi-630002

Mob: +91 - 94431 37972 - 95007 98007

Email: skmperi@yahoo.com

Website: www.skmbuilders.in

VASANTH PLANNERS & DESIGNERS

Er.K.BABU, B.E., M.Sc., (Valuation)
Er.K.VIJAYABANU, M.Tech., MBA., M.Sc., (Valuation)
Licenced Building Surveyors

Office :

#13-V.C.M. Street, K.V.S.Complex (1st Floor)
(Opp.to New Bus Stand)
Tirupattur - 635 601. Vellore Dist.
Cell : 94862 81975, 94869 66002, 94868 49126
Ph : 04179 - 221975



We Undertake : Building Plans, Designs, Estimates, Lay - Out, Supervising etc...
(All are done in computer as per the Vasthu Szssthira)

CERTIFICATE

This is to certify that **MOHAMMED RAIYAN K A** (RRN: 150011601130) studying in B. S. Abdur Rahman Crescent Institute of Science and Technology, Vandalur, Chennai – 48 has attended training during the period from 06/06/2018 to 08/07/2018. During the training period he is fully involved in

AutoCad drawing work.

u.v.jk 7.18.
Er. K. VIJAYA BANU
M.Tech.,MBA.,M.Sc.(Valuation)
Licensed Civil Engineer & Valuer
Vasanth Planners & Designers
13-E, V.C.M. Street, Ist Floor,
(Near Bus Stand)
TIRUPATTUR-635 601. Vellore Dt.
Cell: 94869 66002, 94862 81975
Signature / With seal



In The Name Of Allah

MAMMU CONSTRUCTION

23, NEW BAZAAR, KADAYANALLUR - 627751 CELL : +91 9788735809 PH : 04633 240252

Date :

CERTIFICATE

This is certify that **ABDUL HALIQ E.A. (RRN: 150011601002)** studying in B.S. Abdur Rahman Crescent Institute of Science and Technology, Vandalur, Chennai - 48 has attended training during the period from **10/06/2018** to **10/07/2018**. During the training period he is fully involved in preparation of **RESIDENTIAL BUILDING PROJECT IN, KADAYANALLUR - 627751, TIRUNELVELI DISTRICT, TAMILNADU, INDIA.**

Signature / With Seal

For MAMMU CONSTRUCTION

PROPRIETOR

Fr. O. Saravana Kumar

Mobile : 94426 12392

Ph : 0452-2589295



SARAVANA

Construction & Traders

No. 171, 2nd Floor, Opp. A.R. Hospital, K.K. Nagar, Madurai - 625 020, E-mail : sss_kumar_B4@yahoo.com

CERTIFICATE

This is to certify that ABDUL RAHMAN.S(RRN. 150011601004)studying (B.Tech Civil) in B.S.Abdur Rahman Crescent Instituteof Science and Technology,Vandalur, Chennai – 48. Has attended training during the period from 08.06.2018 to 07.07.2018 during the training period he is fully involved in preparation of Estimate, Construction and Supervision works.

Signature / with seal

For SARAVANA CONSTRUCTION AND TRADERS

Proprietor



M.R. CONSTRUCTIONS

An ISO 9001 : 2008 Certified Company

Lion.MJF Er. **V.MUTHU** BE, MIE, FIV, M.Sc. (Valuation), C.E. (I), M.I.C.
Chartered Engineer (India) - Reg. No.: M-136315/2
Approved Valuer (I.O.V.) - Reg. No.: F-11281
Registered Valuer, Govt. of India (I.T.) - Reg. No.: 07/2004-05

Plan, Estimate, Layout, Structural Design, Constructions, Valuation Reports, Consulting, Supervision Work & Vasthu

Panel Engineer / Valuer : State Bank of India, Canara Bank, Indian Bank, Axis Bank, The South Indian Bank Ltd., Punjab & Sind Bank, TAICO Bank, LIC (HFL), TIIC, Repco Bank, Repco Home Finance Ltd., SBI (SARFAESI), Bank of India (SARFAESI)

CERTIFICATE

This is Certify that **Mr. A.Abdul Wahab** (RRN. 150011601005) Studying in **B.S.Abdur Rahman Crescent Institute of Science and Technology, Vandalur, Chennai-48**, has attended training during the period from **05.06.2018 to 15.06.2018 and 20.06.2018 to 10.07.2018**, during the training period he is fully involved in Preparation of Building **Planning & Estimation with Supervision.**



Signature/ with seal

Er. V. MUTHU, B.E., M.I.E., F.I.V., M.Sc. (Valuation)
Registered Valuer Govt. of India (I.T.)
Reg. No:07/2004-05 (Wealth Tax)
Chartered Engineer, Consulting Civil Engineer
Panel Valuer for L.I.C., TIIC & Banks
M.R. CONSTRUCTIONS
No:25, "Ever Green Complex", College Road
Karaikudi - 2, Sivagangai District.
Ph:04565-226127, Cell: 94432-26127

📍 25, Ever Green Complex, College Road, KARAIKUDI - 630 002. ☎ 04565 - 226127 📞 94432 26127, 63855 40870

✉ valermuthu@gmail.com / mrconstructions@gmail.com 🌐 mrconstructions.org



شركة الأربعة أركان الدولية للمقاولات - فرع جدة

FOUR CORNERS INTERNATIONAL CONSTRUCTION CO. - Jeddah Branch

الرقم : _____
التاريخ : _____
Ref.: _____
Date: _____
12 July 2018

TO WHOM IT MAY CONCERN

This is to certify that **ABDULAH ZAMEER SHAIK**, a student of **B.Tech (CIVIL)** studying in **B.S. Abdur Rahman Crescent Institute of Science and Technology-India**, has successfully completed the training in our buildings project during the period from 11/06/2018 to 11/07/2018.

During the training period, he is fully involved in all type of civil works on construction site i.e. checking of steel works, shuttering works, concrete pouring, block work and plastering works etc., of Residential Compound Project in Jeddah, Saudi Arabia.

Omar Ashkar Adi

General Manager



Head Office : P.O. Box 62877 Riyadh 11595 - Tel.: 4788520 - Fax: 4785453
Jeddah Branch: P.O. Box 14552 Jeddah 21434 - Tel.: 6629050 - Fax: 6629037
C.R. 4030160085 - Chamber of Commerce 105959

المركز الرئيسي : ص.ب ٦٢٨٧٧ الرياض ١١٥٩٥ - هاتف : ٤٧٨٨٥٢٠ - فاكس : ٤٧٨٥٤٥٣
فرع جدة : ص.ب ١٤٥٥٢ جدة ٢١٤٣٤ - هاتف : ٦٦٢٩٠٥٠ - فاكس : ٦٦٢٩٠٣٧
س.ت : ٤٠٣٠١٦٠٠٨٥ - اشترالك الغرفة التجارية : ١٠٥٩٥٩



ASEERA FOUNDATION

16/127, Bajanai Koil Street, (Ibarajapuram 1st street)
Choolaimedu, Chennai - 600 094

CERTIFICATE

This is certify that Mr. Abubacker Siddiq. M (RRN. 150011601008) studying in B.S.Abdur Rahman Crescent Insitute of Science and Technology, Vandalur, Chennai – 48 has attended training during the period from 06.06.2018 to 05.07.2018. during the training period he is fully involved in preparation of Construction Activities.

For ASEERA FOUNDATIONS PVT. LTD.

Managing Director

Signature / With seal

(To be issued in the Company's Letterhead)

CERTIFICATE

This is certify that AFFAN . S (RRN.150011601009)

studying in B.S.Abdur Rahman Crescent Insitute of Science and Technology, Vandalur, Chennai - 48 .

has attended training during the period from 06/06/2018 to 02/07/2018.

during the training period he is fully involved in preparation of project activities like
RCC STRUCTURE, Block work, Plaster and tiling work.

Signature / With seal



Scanned by CamScanner

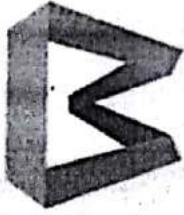

BaraMarzan Construction Pvt.Ltd

karisavayal
Pattukkotai
Thanjavur
Pin code -614723

Mobile No :8012033311
Email Id :ofc.bmc@gmail.com

CERTIFICATE

This is certify that Mr.AFSAR KHANA (RRN.150011601010) studying in B.S. Abdur Rahman Crescent Institute of Science and Technology, Vandalur, Chennai – 48 has attended training during the period from 16/06/18 to 17/07/18 during the training period he is fully involved in preparation of Managing of site work.



CERTIFICATE

This is to certify that Mr. AFZAL AHAMED (RRN. 150011601011) studying in B. S. Abdur Rahman Crescent Institute of Science and Technology, Vandalur, Chennai – 48 has attended training during the period from 10.06.2018 to 09.07.2018 during the training period he is fully involved in preparation of COLUMN & SLAB WORK.

Signature With Seal





கல்ஃப் கன்ஸ்ட்ரக்ஷன் & கன்சல்டன்சி GULF CONSTRUCTION & CONSULTANCY

5/126, East Street, Muslim Bazaar KILAKARAI. Ph : 04567-242277, Mob : 90421 83307
E-mail : gccklk@gmail.com

CERTIFICATE

This is certify that Mr.AHAMED NILAF (RRN. 1500 11 601013)

studying in B.S.Abdur Rahman Crescent Insitute of Science and Technology, Vandalur,Chennai – 48

has attended training during the period from 09-06-2018 to 09-07-2018.

during the training period he is fully involved in preparation of SITE SUPERVISING.



Signature / With seal
09/07/18
GULF CONSTRUCTION & CONSULTANCY
5/126, East Street, Myslim Bazaar,
KILAKARAI - 623517



SEA SKY (IMPORTS AND EXPORTS)

#7/4, New Tank Street
Nungambakkam,
Chennai - 600 034. Tamilnadu
E-mail : info@seaskyimpex.com
Web : www.seaskyimpex.com
Tel : 044 - 2822 5894

Date : 15/07/2018

CERTIFICATE

This is to certify that **AJMAL AKRAM (RRN 150011601014)** studying in B.S .Abdur Rahman Crescent Institute of science and Technology, Vandalur Chennai-48 has attended Training during the period from **08/06/2018** to **10/07/2018**. During the training period he is fully Involved in preparation of **RESIDENTIAL BUILDING PROJECT IN ECR (UTHANDI), CHENNAI, TAMILNADU, INDIA.**



A. M. H.



J/HRIR/292/18

Date- 13.07.2018

TO WHOM IT MAY CONCERN

This is to certify that, **ANAS FURKHAN N.I.**, a student of **B.Tech (CIVIL)**, of **CRESCENT INSTITUTE OF SCIENCE & TECHNOLOGY**, has successfully completed the Internship & project entitled "**PLASTIC ROAD**" from **21th JUNE'18 to 13th JULY'2018**.

The project report was submitted to JUSCO and it was found good. During his Internship, he was found to be very hardworking, dedicated and disciplined.

We wish him the best for the future.

D.K SINGH,

Manager, Training

Er. O. Saravana Kumar

Mobile : 94426 12392

Ph : 0452-2589295



SARAVANA
Construction & Traders

No. 171, 2nd Floor, Opp. A.R. Hospital, K.K. Nagar, Madurai - 625 020. E-mail : sss_kumar_84@yahoo.com

CERTIFICATE

This is to certify that ANTONY ROSARIOMERVYN. E (RRN. 150011601017) studying (B.Tech Civil) in B.S. Abdur Rahman Crescent Institute of Science and Technology, Vandalur, Chennai - 48. Has attended training during the period from 08.06.2018 to 07.07.2018 during the training period he is fully involved in preparation of Estimate, Construction and Supervision works.

Signature / with seal

For SARAVANA CONSTRUCTION AND TRADERS

Proprietor



Executive Engineer and Administrative Officer,
Besant Nagar Division
Tamil Nadu Housing Board,
Adyar, Chennai-600020.
Phone No. : 044-24913561

CERTIFICATE

This is certifying that ASHIK J (RRN. 150011601019) studying (B.Tech Civil) in B.S.Abdur Rahman Crescent Institute of Science and Technology, Vandalur, Chennai – 48. has attended training period from 08.06.2018 to 07.07.2018, during the training period he is fully involved in preparation of Estimate, Construction and Supervision works.



Exe.Engineer & Adm. Officer
Besant Nagar Division.

Executive Engineer &
Administrative Officer
Besant Nagar Division
Tamil Nadu Housing Board
Chennai-600 020.



CENTERLINE
ENGINEERING AND CONSTRUCTIONS

BUILDING CONSTRUCTION
REPAIR & RENOVATION
PLAN
ESTIMATE
STRUCTURAL DRAWINGS
APPROVAL DRAWINGS

DATE:12.07.2018

CERTIFICATE

This is to certify that **S.ATHEEK FERNAS, RRN. 150011601023** studying in B.S.Abdur Rahman Crescent Insitute of Science and Technology, Vandalur,Chennai – 48 has attended training during the period from 06.06.2018 to 10.07.2018 during the training period he is fully involved in Site work.

[Handwritten Signature]
Signature / With seal



SEA SKY (IMPORTS AND EXPORTS)

#7/4, New Tank Street
Nungambakkam,
Chennai - 600 034. Tamilnadu
E-mail : info@seaskyimpex.com
Web : www.seaskyimpex.com
Tel : 044 - 2822 5894

Date : 15/07/2018

CERTIFICATE

This is to certify that **BALASUBRAMANIAM (RRN 150011601025)** studying in B.S .Abdur Rahman Crescent Institute of science and Technology, Vandalur Chennai-48 has attended Training during the period from **08/06/2018 to 10/07/2018**. During the training period he is fully Involved in preparation of **RESIDENTIAL BUILDING PROJECT IN ECR (UTHANDI), CHENNAI, TAMILNADU, INDIA.**



KEEN ESTABLISHMENT

A Multi Disciplinary Construction Engineers
False Ceiling & Gypsum Board whole sale retail

Off: Crescent Castle Flat 15/11 Kajamian Street, Kaja Nagar, Trichy-

Mob: 9884867892

Email:keenestablishment@gmail.com

CERTIFICATE

This is certify that **BASHEER AHAMED AATHIL.S (RRN.150011601026)** studying in B.S.Abdur Rahman Crescent Insitute of Science and Technology, Vandalur,Chennai – 48. He has attended training during the period from **05.06.18** to **04.07.18**. During the training period he is fully involved in preparation of **CONSTRUCTION MANAGEMENT AND ORGANIZING WORK.**

Signature With seal





Executive Engineer and Administrative Officer,
Besant Nagar Division
Tamil Nadu Housing Board,
Adyar, Chennai-600020.
Phone No. : 044-24913561

CERTIFICATE

This is certifying that BOOBESH KUMAR T (RRN. 150011601027) studying (B.Tech Civil) in B.S.Abdur Rahman Crescent Institute of Science and Technology, Vandalur, Chennai – 48. has attended training period from 08.06.2018 to 07.07.2018, during the training period he is fully involved in preparation of Estimate, Construction and Supervision works.

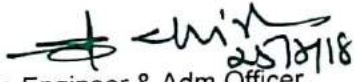

Exe.Engineer & Adm.Officer
Besant Nagar Division.

Executive Engineer &
Administrative Officer
Besant Nagar Division
Tamil Nadu Housing Board
Chennai-600 020.



DEPARTMENT OF CIVIL ENGINEERING
INDIAN INSTITUTE OF TECHNOLOGY MADRAS

CERTIFICATE

This is to certify that

BURHANUDDIN LOKHANDWALA

B.Tech student of B.S.ABDUL RAHAM CRESCENT INSTITUTE OF
SCIENCE & TECHNOLOGY, CHENNAI
has participated in the Summer Fellowship Programme (SFP)-2018
at Department of Civil Engineering, IIT Madras
from 16th May 2018 to 13th July 2018.

Prof. K. Ramamurthy
Head of the Department

LA



VENKATESA ASSOCIATES

ENGINEERS & ARCHITECTS

All types of Civil & Structural Estimation, Design, Drawings, Valuations, E.P. Plants, Godowns, Weigh Bridges, School Buildings, Hospitals and all types of Machinery Foundations like Turbines, Boilers etc.,

Head Office :
Er. CH. SRINIVASA RAO B.E. (CIVIL)
D.No. 2-150, Rayuduvaripalem Jn.,
Pithapuram Road, A.P.S.P.,
KAKINADA - 5
Cell : 94403 14566, 93921 22896.
e-mail : venkatesaassociates@gmail.com

Branch Office
Er. K. Venkata Sai Babu
4th Street, Bypass Road,
Sri Chakka Suryanarayana Nagar,
Payakaraopeta, Vishaka Dist,
Ph : 08854-200144, 9247358426
e-mail : kompellavenkatassai.babu@gmail.com

Date : 9/07/2018

TO WHOM SO EVER IT MAY CONCERN

This is to certify that Mr. Dasuri Sumanth, RRN 150011601029, s/o Sri Dasuri Sudhakar Rao, who is studying B.Tech (civil engineering) final year in B.S. Abdur Rahman Crescent Institute of Science and Technology at Chennai attended on the following works for Internship from 04-06-2018 to 05-07-2018 under our guidance.

1. Construction of Sri Dhana Lakshmi Jewellery shop at Tuni, East Godavari dist., Andhra Pradesh.

He has been excellent throughout the work during his internship.

VENKATESA ASSOCIATES
BY VENKATESA ASSOCIATES
K. V. S. B.
Er. K. VENKATA SAI BABU



Executive Engineer and Administrative Officer,
Besant Nagar Division
Tamil Nadu Housing Board,
Adyar, Chennai-600020.
Phone No. : 044-24913561

CERTIFICATE

This is certifying that GOWTHAMRAJ.L (RRN. 150011601030) studying (B.Tech Civil) in B.S.Abdur Rahman Crescent Institute of Science and Technology, Vandalur, Chennai – 48. has attended training period from 08.06.2018 to 07.07.2018, during the training period he is fully involved in preparation of Estimate, Construction and Supervision works.



[Handwritten signature]
25/7/18

Exe.Engineer & Adm.Officer
Besant Nagar Division.

Executive Engineer &
Administrative Officer
Besant Nagar Division
Tamil Nadu Housing Board
Chennai-600020.



J/HRIR/290/18

Date- 13.07.2018

TO WHOM IT MAY CONCERN

This is to certify that, **HAFIZ AAMIR AHMAD**, a student of **B.Tech (CIVIL)**, of **CRESCENT INSTITUTE OF SCIENCE & TECHNOLOGY**, has successfully completed the Internship & project entitled "**PLASTIC ROAD**" from **21th JUNE'18 to 13th JULY'2018**.

The project report was submitted to JUSCO and it was found good. During his Internship, he was found to be very hardworking, dedicated and disciplined.

We wish him the best for the future.

D.K SINGH,

Manager, Training

ESCON COSTRUCTION

DATE: 04.07.2018

THIS IS CERTIFY THAT J. HAJEE ALI (RRN 150011601032) STUDING IN B.S. ABDUR RAHAMAN CRESCENT INSITUTE OF SCIENCE AND TECHNOLOGY, VANDALUR, CHENNAI-48 HAS ATTENDED TRAINING THE PERIOD FROM 06.06.2018 TO 04.07.2018 DURING THE TRAINING PEROD HE IS FULLY INVOLVED IN PREPARATION OF WORK SCHEDULE.

ER G.SELLADURAI

Er. G. SELLADURAI, DCE.,
ESCON PROJECTS,
1st Floor, VKS. Plaza, South Main St,
THIRUVARUR - 610 001.
Cell: 97509 70741

NO. 115, D. W. NALLA ROAD, THIRUVALUR - 610 001.



Sree's Builders & Promoters

71, 3rd Main Road, Mogappair West, Nolambur, Chennai – 600 037
Mobile : 9841013988,

06.07.2018

This is to certify that **Mr. P. HARCHARAN**, Regn. No.150011601033 studying at B.S.Abdur Rahman Crescent Institute of Science and Technology, Vandalur, Chennai – 600045 has attended training during the period from 04.06.2018 to 03.07.2018.

He has found to be good, punctual and observant during the training period.

For SREE'S
BUILDERS & PROMOTERS

Proprietor



Sree's Builders & Promoters

71, 3rd Main Road, Mogappair West, Nolambur, Chennai – 600 037
Mobile : 9841013988,

06.07.2018

This is to certify that **Mr. P. HARCHARAN**, Regn. No.150011601033 studying at B.S.Abdur Rahman Crescent Institute of Science and Technology, Vandalur, Chennai – 600045 has attended training during the period from 04.06.2018 to 03.07.2018.

He has found to be good, punctual and observant during the training period.

For SREE'S
BUILDERS & PROMOTERS

Proprietor



Executive Engineer and Administrative Officer,
Besant Nagar Division
Tamil Nadu Housing Board,
Adyar, Chennai-600020.
Phone No. : 044-24913561

CERTIFICATE

This is certifying that HARIHARAN.S (RRN. 150011601035) studying (B.Tech Civil) in B.S.Abdur Rahman Crescent Institute of Science and Technology, Vandalur, Chennai – 48. has attended training period from 08.06.2018 to 07.07.2018, during the training period he is fully involved in preparation of Estimate, Construction and Supervision works.

Exe.Engineer & Adm.Officer
Besant Nagar Division.



Er. O. Saravana Kumar

Mobile : 94426 12392

Ph : 0452-2589295



SARAVANA
Construction & Traders

No. 171, 2nd Floor, Opp. A.R. Hospital, R.K. Nagar, Madurai - 625 020. E-mail : sss_kumar_B46@yahoo.com

CERTIFICATE

This is to certify that IMRAN KHAN.A(RRN. 150011601037) studying (B.Tech Civil) in B.S.Abdur Rahman Crescent Institute of Science and Technology, Vandalur, Chennai - 48. Has attended training during the period from 08.06.2018 to 07.07.2018 during the training period he is fully involved in preparation of Estimate, Construction and Supervision works.

Signature / with seal

For SARAVANA CONSTRUCTION AND TRADERS

Proprietor

Date: 09.07.2018

THIS IS HEREBY CERTIFIED THAT

Mr. S. Mahathoom Ibrahim (RRN 150011601042)

Studying in B.S.Abdur Rahman Crescent Institute of Science and Technology ,
Vandalur, Chennai – 48 has attended training during the period from 04/06/2018
to 09/07/2018 . During the training period he is fully involved in the preparation
of Estimation , Material Requirements and Site supervision.

For ShaRa Constructionss,

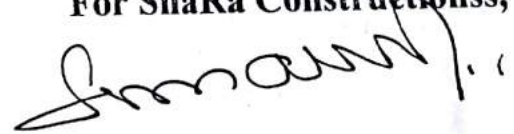

Authorized Signatory

SHARA CONSTRUCTIONSS

Engineers and Contractors

B 131/1/1, 2nd Cross Street,

Regmath Nagar,

PALAYAMKOTTAI - 627 011.



EliteHomes

CONSTRUCTIONS

CERTIFICATE

This is to certify that **MD SHUAIB SAQIB B (RRN: 150011601046)** studying in B.S.Abdur Rahman Crescent Insitute of Science and Technology, Vandalur,Chennai – 48 has attended training during the period from 10-06-18 to 09-07-18. during the training period he is fully involved in preparation of **CONSTRUCTION MANAGEMENT AND ORGANIZING WORK .**

Elite Homes
892/3C, Weekly Market Road,
Khaderpet, Vaniyambadi-635751
S. Elia
Signature / With seal

#892,Weekly market road khaderpet vaniyambadi-635751



G.A CONSTRUCTIONS

CERTIFICATE

This is to certify that Mr. **P.M.I. MOHAMED ABDULLAH** (RRN. 150011601048) studying in B.S.Abdur Rahman Crescent Insitute of Science and Technology, Vandalur,Chennai – 48 has attended training during the period from 04 -06-2018 to 04- 07-2018. During the training period he is fully involved in all Site Works of our projects.

Signature / With seal
GA CONSTRUCTIONS
31, Kuthukal Street,
Kayalpatinam - 628 204.

Office Address
#31, Kuthukal Street, Kayalpatam – 628204
Mobil: 9659822998 | 8220524878



S.R. Builders

Licensed Builders & Contractors

Mobile : 94437 - 45274
98433 - 55760

10 - A, 50 Feet Road,
Sellur, Madurai - 625 002.
e-mail : srbuilders08@yahoo.com

CERTIFICATE

This is certify that Z. Mohamed Afrath Khan (RRN. 150011601050) studying in B.S.Abdur Rahman Crescent Insitute of Science and Technology, Vandalur,Chennai – 48 has attended training during the period from June 10 to July 10. During the training period he is fully involved in preparation of gaining more technical terms about the work.

For S.R. BUILDERS

S. Sift
Proprietor
Signature



CERTIFICATE

This is certify that J.MOHAMED AFZAR (RRN.
) studying in B.S.Abdur Rahman Crescent Insitute of Science and Technology, Vandalur,Chennai – 48 has
attended training during the period from 05-06-2018 to 05-07-2018 during
the training period he is fully involved in preparation of site supervising and construction
ideas_____.

Er. A.MANSOOR, M.Tech (Structure)
Consulting Engineer & Licensed Surveyor
MODERN CONSTRUCTIONS & STRUCTURAL CONSULTANT
Main Road, MADUKKUR-614 903
Ph: 88 70 62 63 64

Signature / With seal

AL-SHIFA BUILDERS

Off: 94431-40712
No.3, Uma Complex,
Rajaram Salai, K.K. Nagar, Trichy.21.

Resi:2455045
No.13, Mahalakshmi Nagar 3rd street,
K.K. Nagar, Trichy - 620 021.

Er, M. Asraf Ali, B.E., MBA.,
Consulting Civil Engineer &
Licensed Surveyor 115/2018-2019
Tiruchirapalli corporation,
Tiruchirapalli district.

CERTIFICATE

This is certify that MOHAMED AKHIL M M (RRN.150011601052) studying in B.S.Abdur Rahman Crescent Insitute of Science and Technology, Vandalur,Chennai – 4 has attended training during the period from 1/06/2018 to 30/06/2018.during the training period he is fully involved in preparation of **DRAWING AND NETWORK TECHNIQUES.**



Signature / With seal

ER M. ASRAF ALI, E.E.,
CONSULTING ENGINEER &
LICENSED SURVEYOR
TIRUCHIRAPALLI CORPORATION
TIRUCHIRAPALLI.



M.R. CONSTRUCTIONS
An ISO 9001 - 2008 Certified Company

Lion.MJF.Engr. **V.MUTHU** B.E., M.E., F.I.V., M.Sc., (Valuation), C.E.(I), M.I.C.A.
Chartered Engineer (India) - Reg. No.: M-136315/2
Approved Valuer (I.O.V.) - Reg. No.: F-11281
Registered Valuer, Govt. of India (I.T.) - Reg. No.: 07/2004-05

Plan, Estimate, Layout, Structural Design, Constructions, Valuation Reports, Consulting, Supervision Work & Vasthu
Panel Engineer / Valuer : State Bank of India, Canara Bank, Indian Bank, Axis Bank, The South Indian Bank Ltd., Punjab & Sind Bank, TAICO Bank, LIC (HFL), TIIC, Repco Bank, Repco Home Finance Ltd., SBI (SARFAESI), Bank of India (SARFAESI)

CERTIFICATE

This is Certify that **M.Mohamed Faizal** (RRN. 150011601054) Studying in **B.S. Abdur Rahman Crescent Institute of Science and Technology, Vandalur, Chennai-48,** has attended training during the period from **05.06.2018 to 15.06.2018 and 20.06.2018 to 10.07.2018,** during the training period he is fully involved in Preparation of **Plan & Estimation cum Building Supervision.**



Signature/ with seal

(Signature)
V.MUTHU, as a Panel Engineer
Registered with Govt. of India
Reg. No. 07/2004-05
Approved Valuer (I.O.V.) - Reg. No. F-11281
Registered Valuer, Govt. of India (I.T.) - Reg. No. 07/2004-05

Scanned by CamScanner



கல்ஃப் கன்ஸ்ட்ரக்ஷன் & கன்சல்டன்ஸ்
GULF CONSTRUCTION & CONSULTANCY
5/126, East Street, Muslim Bazaar KILAKARAI. Ph : 04567-242277, Mob : 90421 8330
E-mail : gccklk@gmail.com

CERTIFICATE

This is certify that Mr.MOHAMED HASAN RAIF (RRN. 150011601055)
studying in B.S.Abdur Rahman Crescent Insitute of Science and Technology, Vandalur,Chennai – 48
has attended training during the period from 03-06-2018 to 07-07-2018 during the training period he
is fully involved in preparation of SITE ENGINEER.



Signature / With seal

[Handwritten Signature] 07/07/18

GULF CONSTRUCTION & CONSULTANCY
5/126, East Street, Myslim Bazaar,
KILAKARAI - 623517

M.Md. SHERIFF MBA
Managing Partner

Er. M.Md. ASHIQ SALMAN M.Tech
Partner

Sep 10, 2018

TO WHOMSOEVER IT MAY CONCERN

This is to Certify that Mr.Mohamed Irfan M B (Regn.No.150011601056) Final Year B.Tech Civil Engineering Student of B.S.Abdur Rahman Crescent Institute of Science and Technology has successfully completed implant Training in our Annex Block, Measi Academy of Architecture, New College, Chennai-14 Site under the guidance of Mr.S.Chinnadurai Senior Engineer during the period of 4th June 2018 - 3rd July 2018. During the training period he is fully involved in assisting work in the Project. He was sincere during the period of training.

We wish him success in all his future endeavors.

For MSA BUILDERS & PROMOTERS

(Mohamed Sheriff)



In the name of allah

MAMMU CONSTRUCTION

23, NEW BAZAAR, KADAYANALLUR - 627751 CELL : 9788735809 PH : 04633 240252

Date: 06-07-2018

CERTIFICATE

This is to certify that **MOHAMED ISMAIL .A.S. (RRN.150011601057)** studying in B.S.Abdur rahman crescent Institute of Science and Technology ,Vandalur Chennai – 48 has attended training during the period from 05/06/2018 to 06/07/2018 during the training period he is fully involved in preparation of **RESIDENTIAL BUILDING PROJECT IN KADAYANALLUR – 627751, TIRUNELVELI TAMILNADU INDIA.**

For MAMMU CONSTRUCTION

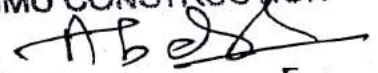

PROPRIETOR

Signature / with Seal



EliteHomes

CONSTRUCTIONS

CERTIFICATE

This is to certify that **MOHAMED MUZAMMIL V (RRN: 150011601058)** studying in B.S.Abdur Rahman Crescent Institute of Science and Technology, Vandalur.Chennai – 48 has attended training during the period from 10-06-18 to 09-07-18. during the training period he is fully involved in preparation of **CONSTRUCTION MANAGEMENT AND ORGANIZING WORK.**

Elite Homes
892/3C, 1 Weekly Market Road
Khaderpet, Vaniyambadi-63575
S. R. S.
Signature / With seal

KEEN ESTABLISHMENT

A Multi Disciplinary Construction Engineers
False Ceiling & Gypsum Board whole sale retail

Off: Crescent Castle Flat 15/11 Kajamian Street, Kaja Nagar, Trichy-

Mob: 9884867892

Email: keenestablishment@gmail.com

CERTIFICATE

This is certify that **MOHAMED NASURUDEEN.H** (RRN. 150011601059) studying in B.S.Abdur Rahman Crescent Insitute of Science and Technology, Vandalur, Chennai – 48. He has attended training during the period from **05.06.18** to **04.07.18**. During the training period he is fully involved in preparation of **CONSTRUCTION MANAGEMENT AND ORGANIZING WORK.**

Signature





SHEKAR CONSTRUCTION
ENGINEER & CONTRACTOR

: 240075 (Off)
☎ : 240366 (Resi)
: 94431 24034
: 94431 24033
e-mail : shekar_pvm@yahoo.co.in

DATE :

CERTIFICATE

This is certify that **MOHAMED RIYAZ.M** (RRN.150011601061) studying in B.S.Abdur Rahman Crescent Institute of Science and Technology, Vandalur, Chennai – 48. He has attended training during the period from **08.06.18** to **09.07.18**. During the training period he is fully involved in preparation of **CONSTRUCTION MANAGEMENT AND ORGANIZING WORK**.

Signature / With seal

Er. R. KALIAPERUMAL, B.Tech.,
Municipal Licensed Surveyor.
SHEKAR CONSTRUCTION,
31/2, South Main Street,
TIRUVARUR.
Ph: 240075, Cell: 9443124034.

31/2, SOUTH MAIN STREET, THIRUVARUR, 610 001.



G.A CONSTRUCTIONS

CERTIFICATE

This is to certify that Mr. **K.S.L. MOHAMED SADAKATHULLAH** (RRN. 150011601062) studying in B.S.Abdur Rahman Crescent Insitute of Science and Technology, Vandalur,Chennai – 48 has attended training during the period from 04 -06-2018 to 04- 07-2018. During the training period he is fully involved in all Site Works of our projects.

Signature / With seal
15/08/18

GA CONSTRUCTIONS
31, Kuthukal Street,
Kayalpatnam - 628 204.

Office Address

#31, Kuthukal Street, Kayalpatam – 628204
Mobil: 9659822998 | 8220524878

Regn. No. 474



PERFECT CONSTRUCTIONS

Engineers & Contractors

Ln. Er. M. BALAMOUGANE,

Licensed Civil Engineer-KPA
Govt. Contractor

Date:.....

10.07.2018
Karaikal

CERTIFICATE

This is certify that **MOHAMED SAEED MAHADHI S M**, (RRN 150011601063) studying in B.S.Abdur Rahman Crescent Institute of science and Technology, Vandalur, Chennai - 48 has attended training during the period from **4th June 2018 to 5th July 2018**. During the training period, he is fully involved in construction of wall, staircase and curing process. He was found to be effective, hardworking and inquisitive through the training period.

Signature / with seal

PERFECT CONSTRUCTIONS
81/6, Church Street
Karaikal - 609602



BALAJI ASSOCIATES

*1-6A, Rajan Complex (First Floor), Forest Main Road, Theni - 625 531
Mobile : 98945 97379, 90920 97379 E-mail : shenba.subam@gmail.com*

N. SHENBAGARAJAN, B.E.,
Civil Engineer

INTERNSHIP CERTIFICATE

This is certify that **NIHILESH.K** (RRN. 150011601079) studying in B.S.Abdur Rahman Crescent Institute of Science and Technology, Vandalur, Chennai – 48 has attended training during the period from **09.06.2018** to **08.07.2018**. During the training period he is fully involved in the preparation of entire construction work.

SIGNATURE / WITH SEAL

Er. N. SHENBAGARAJAN, B.E.,
1-6A, Rajan Complex, 1st Floor,
Forest Main Road, THENI-625 531.
Mob: 98945 97379, 9092097379

CERTIFICATE

This is to certify that DINESH KUMAR B (RRN 150011601122) studying in B.S.ABDUR RAHMAN Crescent institute of science and technology, vandalur, Chennai:48 . He has attended training during the period from 08.06.2018 to 09.07.2018. During the training period he is fully involved in preparation of construction work

For ABABIL HERITAGE

J. Md. Gm

Proprietor



MSA Builders & Promoters

No.2, Salam Barr, Ganesapuram street,
Cenotaph Road, Teynampal, Ch- 600 016.
[Ph:044-2436 3685 | Mob: 94440 73373, 9845645919]
Email: msabuildersandpromoters@gmail.com

Md. SHERIFF MBA
Managing Partner

Er. M.Md. ASHIQ SALMAN M.Tech
Partner

Sep 10, 2018

TO WHOMSOEVER IT MAY CONCERN

This is to Certify that Mr.Rabi-ur-Rahman (Regn.No.150011601134) Final Year B.Tech Civil Engineering Student of B.S.Abdur Rahman Crescent Institute of Science and Technology has successfully completed implant Training in our Annex Block, Measi Academy of Architecture, New College, Chennai-14 Site under the guidance of Mr.S.Chinnadurai Senior Engineer during the period of 4th June 2018 - 3rd July 2018. During the training period he is fully involved in assisting work in the Project. He was sincere during the period of training.

We wish him success in all his future endeavors.

For MSA BUILDERS & PROMOTERS

(Mohamed Sheriff)

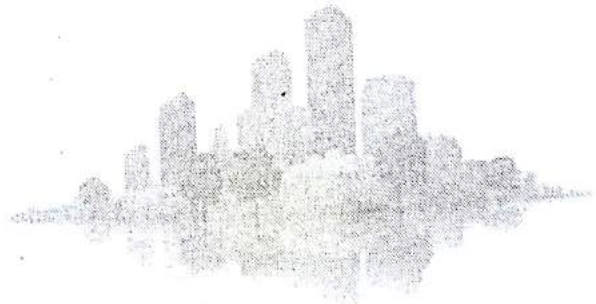



SEA SKY (IMPORTS AND EXPORTS)

#7/4, New Tank Street
Nungambakkam,
Chennai - 600 034. Tamilnadu
E-mail : info@seaskyimpex.com
Web : www.seaskyimpex.com
Tel : 044 - 2822 5894

Date : 15/07/2018

CERTIFICATE

This is to certify that **SHAHID HAFEEZ (RRN 150011601135)** studying in B.S .Abdur Rahman Crescent Institute of science and Technology, Vandalur Chennai-48 has attended Training during the period from **08/06/2018 to 10/07/2018**. During the training period he is fully Involved in preparation of **RESIDENTIAL BUILDING PROJECT IN ECR (UTHANDI), CHENNAI, TAMILNADU, INDIA.**



(Handwritten signature)



MSM Enterprises

Phone : +91-9841689595
Address : No.4,MSM Tower,
1st Floor, Yadaval St,
Padi, Chennai-600050

Civil Eng. Contractor

CERTIFICATE

This is certify that S.S.T. ANBARI (RRN. 150011601137)
studying in B.S.Abdur Rahman Crescent Insitute of Science and Technology, Vandalur,Chennai - 48
has attended training during the period from 9th JUNE 2018 to 9th july 2018
during the training period he is fully involved in preparation of BT Road works

for **M.S.M. Enterprises**

A.M. [Signature]
Proprietor
Signature / With seal



भारतीय राष्ट्रीय राजपार्ग प्राधिकरण
(पीन सडक परिवहन और राजमार्ग मंत्रालय)

National Highways Authority of India

(Ministry of Road Transport & Highways)

Office of the Project Director, P.I.U.,

No.26, 1st Floor, V.G.P. Nagar West, Vazhudhareddy Post
Viluppuram - 605 401. Tamil Nadu.

Tele :04146 - 258247
Tele Fax : 04146 -258248
Email : viluppuram@nhai.org
nhaiupm@hotmail.com
piuvpm.nhai@gmail.com

NHAI/PIU/VPM/2018/885

4th July 2018

To Whom so ever it may concern

Ref: B.S. Abdur Rahman Crescent Institute of Science & Technology,
Vandalur. Dt. 07.06.2018.

This is to certify that **Shri. A. Mohamed Aslam, S/o. Mohamed Anvar** studying, third year (Sixth Semester), Civil engineering at B.S. Abdur Rahman Crescent Institute of Science & Technology, Vandalur has undergone vocational training in project Implementation Unit, Villupuram, National Highways Authority of India, from, 04.06.2018 to 03.07.2018 .

During his training period, he has gone through the various aspects of four lane projects under implementation and to be implemented.

Yours faithfully,

(T.V. Sivaji),
General Manager (T) &
Project Director,
Villupuram.

Head Office: G - 5&6, Sector - 10, Dwarka New Delhi - 110 075. Website: www.nhai.org
Regional Office: Plot No.P-34,3rd Floor, Sri Towers(SP) Industrial Estate, Guindy, Chennai - 600 032.



Office of The Deputy Technical Officer, APTIDCO, Nellore

CERTIFICATE

It is to certify that Mr.Pernati Nischal Siddharth (RRN.150011601144) B.Tech. in CIVIL , student of Cresçent Institute of Science & Technology, Vandalur, Chennai has taken Internship in APTIDCO, Nellore Division (Naidupeta works) from 03.06.2018 to 02.07.2018 and participated in Civil Engineering activities like foundations of buildings, Plinth beams etc., .

During the above period his performance is good.

Dy. TECHNICAL OFFICER 3.7.2018
APTIDCO : NELLORE ✓

In the name of allah

MAMMU CONSTRUCTION

23, NEW BAZAAR, KADAYANALLUR - 627751 CELL : 9788735809 PH : 04633 240252

Date : 06-07-2018

CERTIFICATE

This is to certify that **ARSATH HAMEED.O.A (RRN.150011602008)** studying in B.S.Abdur rahman crescent Institute of Science and Technology ,Vandalur Chennai – 48 has attended training during the period from 05/06/2018 to 06/07/2018 during the training period he is fully involved in preparation of **RESIDENTIAL BUILDING PROJECT IN KADAYANALLUR – 627751, TIRUNELVELI TAMILNADU INDIA.**

For MAMMU CONSTRUCTION

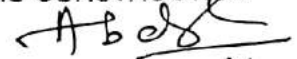

PROPRIETOR

Signature / with Seal



Bright Way

Trading & Contracting

INTERNSHIP CERTIFICATE

Date: 17-July-2018

This is to certify that Mr. Muhammed Ziad S I, pursuing his B.Tech Civil Engineering at Crescent Institute of Science and Technology, Chennai, India has successfully completed Summer internship on Construction of Hamad Port District Roadways & Facility Management Project (100 million Qatari Riyal) at Hamad Port Umseed, Doha, Qatar From 16th June 2018 to 17th -July-2018.

During the period of his internship with us, he assisted the Site Engineer and Works Supervisor. He was found punctual, supportive, resourceful and inquisitive.

Your cooperation and support is highly appreciated 

Thank you & best regards,

JOBY M JOSE

Construction Manager
Brightwave Trading & Contracting Co.
+974 7708 2255



Office: +974 440867, Fax: 974 440867 CR: 77164 Doha, Qatar

www.brightwavwqatar.com, info@brightwave.com



BaraMarzan Construction Pvt.Ltd

karisavayal Pattukkotal Thanjavur Pin code -614723

Mobile No :8012033311

Email Id :ofc.bmc@gmail.com

CERTIFICATE

This is certify that Mr.NISATH HUSSAIN H (RRN.150011601080) studying in B.S. Abdur Rahman Crescent Institute of Science and Technology, Vandalur, Chennai – 48 has attended training during the period from 16/06/18 to 17/07/18 during the training period he is fully involved in preparation of Managing of site work.





BaraMarzan Construction Pvt.Ltd

karlsavayal Pattukkotal Thanjavur Pin code -614723

Mobile No :8012033311

Email Id :ofc.bmc@gmail.com

CERTIFICATE

This is certify that Mr.NISATH HUSSAIN H (RRN.150011601080) studying in B.S. Abdur Rahman Crescent Institute of Science and Technology, Vandalur, Chennai – 48 has attended training during the period from 16/06/18 to 17/07/18 during the training period he is fully involved in preparation of Managing of site work.



AQSA Traders

CERTIFICATE

This is certify that **A. NIHAL AHMED (RRN: 150011601078)** studying in B.S. Abdur Rahman Crescent Institute of Science and Technology, Vandalur, Chennai – 48 has attended training during the period from 04-06-2018 to 04-07-2018. During the training period he is fully involved in preparation of **BRICK WORK , PLASTERING AND SLAB CONCRETE.**



Signature / With seal

#42/65, Jinnah street, Alandur, Chennai-600016.

M.Md. SHERIFF MBA
Managing Partner

Er. M.Md. ASHIQ SALMAN M.Tech
Partner

Sep 10, 2018

TO WHOMSOEVER IT MAY CONCERN

This is to Certify that Mr.M.Mohamed Shafiq Salman (Regn.No.150011601064) Final Year B.Tech Civil Engineering Student of B.S.Abdur Rahman Crescent Institute of Science and Technology has successfully completed implant Training in our Annex Block, Measi Academy of Architecture, New College, Chennai-14 Site under the guidance of Mr.S.Chinnadurai Senior Engineer during the period of 4th June 2018 - 3rd July 2018. During the training period he is fully involved in the preparation of material estimates and assisting technical work in the Project. He was sincere during the period of training.

We wish him success in all his future endeavors.

For MSA BUILDERS & PROMOTERS

(Mohamed Sheriff)



EXCEL CONSTRUCTION COMPANY

5/2-A, Devendrapuram 2nd Street, SALEM - 636 001.

GSTIN : 33AABFE5996N1ZW

Cell : 98424 33411

e-mail : excel_jazzz@yahoo.in

Date :

CERTIFICATE

This is certify that MOHAMMED MUAZZAM M.A (RRN. 150011501068) studying in B.S.Abdur Rahman Crescent Institute of Science and Technology, Vandalur, Chennai – 48 has attended training during the period from 12-06-2018 to 08-07-2018. During the training period he is fully involved in preparation of CONSTRUCTION MANAGEMENT AND ORGANIZATION WORK.

For M/s. Excel Construction Company

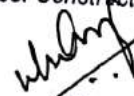

Managing Partner

Signature / With seal



Hansan
BUILDERS

DATE:13.07.2018

INTERNSHIP CERTIFICATE

This is to certify that **Mr.MOHAMMED SALMAANUL HUQQ RRN(150011601070)** a student of **B.E CIVIL ENGINEERING – Final year**, **Crescent Institute Of Science And Technology**, vandalur ,Chennai-600130 has successfully completed 31days (**11.06.2018 to 11.07.2018**) internship programme at this company. During the period of his internship programme with us he was found punctual, hard working and inquisitive.

We wish him every success in life.

Hansan Builders

No:149/96, Radha Nagar Main Road,
Chrompet, Chennai-600 044.
Mobile: 94447 62797, 94446 42431,
Email: hansanbuilders@gmail.com

Yours faithfully,

For HANSAN BUILDERS

PARTNER



In The Name Of Allah

MAMMU CONSTRUCTION

23, NEW BAZAAR, KADAYANALLUR - 627751 CELL : +91 9788735809 PH : 04633 240252

Date :

CERTIFICATE

This is certify that **MOHAMMED SAMEER K.H. (RRN: 150011601071)** studying in B.S. Abdur Rahman Crescent Institute of Science and Technology, Vandalur, Chennai – 48 has attended training during the period from **04/06/2018** to **05/07/2018**. During the training period he is fully involved in preparation of **RESIDENTIAL BUILDING PROJECT IN, KADAYANALLUR – 627751, TIRUNELVELI DISTRICT, TAMILNADU, INDIA.**

Signature / With Seal

For MAMMU CONSTRUCTION

PROPRIETOR



CERTIFICATE

This is to certify that S. MOHAMMED ASLAM
(RRN 150011601073) studying in B.S. Abdhur
Rahman Institute of Science and Technology, Vandalur,
Chennai- 48 has attended training during the period from
06/06/2018 to 06/07/2018

During the training period he is fully involved in
preparation of Interior wall and column construction

S. Jayaraman

Signature/With Seal

SOUTH INDIA SHELTERS PVT. LTD.
S. JAYARAMAN
Sr. Project Engineer
Signature.....
Date :.....

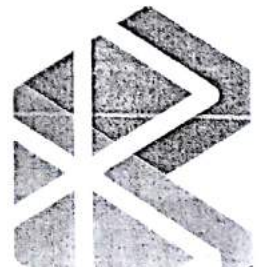



Hansan
BUILDERS

DATE:13.07.2018

INTERNSHIP CERTIFICATE

This is to certify that Mr.MOHAMED M (RRN-150011601047),a student of B.E CIVIL ENGINEERING – Final year ,Crescent Institute Of Science And Technology, vandalur ,Chennai-600130 has successfully completed 31days (11.06.2018 to 11.07.2018) internship programme at this company. During the period of his internship programme with us he was found punctual, hard working and inquisitive.

We wish him every success in life.

Yours faithfully,

For HANSAN BUILDERS

PARTNER

Hansan Builders

No:149/96, Radha Nagar Main Road,
Chrompet, Chennai-600 044.
Mobile: 94447 62797, 94446 42431,
Email: hansanbuilders@gmail.com

HPK STAR PROPERTY DEVELOPERS

Kalanjiyam Apartments, Flat No. B-1, No. 20, East Main Road, Gopal Reddy Colony, (Near Indian Bank Perambur Branch),
Chennai - 600 082. Ph : 42789040 Email : basheerccb@gmail.com

Date

CERTIFICATE

This is to certify that **Mr. S.M. MUJAHITH AFZAL (RRN. 150011601075)** studying in
B.S. Abdur Rahman Crescent Institute of Science and Technology, Vandalur, Chennai -48
Has attended training during the period from **07.06.2018 to 07.07.2018**. During the training
Period he is fully involved in preparation of Managing the site work.

Signature / with seal

For HPK Star Property Developers

Managing Partner

25-July-2018

TO WHOMSOEVER IT MAY CONCERN

This is to certify that Ms. Asmi Shahin .A (Reg No: 150011601020) Crescent Institute Of Technology - Chennai) has undergone internship with Casa Grande Civil Engineering Private Limited from 20/06/2018 to 02/07/2018 in Our Bloom Project – Thirumudivakkam, Chennai.

For Casa Grande Civil Engineering Private Limited

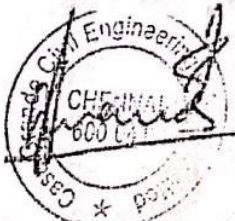

Anand S

Vice President – Human Resources



DATE:13.07.2018

INTERNSHIP CERTIFICATE

This is to certify that **Mr.PRAVEENKUMAR.S (RRN-150011601082)**, a student of B.E CIVIL ENGINEERING – Final year ,**Crescent Institute Of Science And Technology**, vandalur ,Chennai-600130 has successfully completed 31days (**11.06.2018 to 11.07.2018**)internship programme at this company. During the period of his internship programme with us he was found punctual, hard working and inquisitive.

We wish him every success in life.

Hansan Builders

No:149/96, Radha Nagar Main Road,
Chrompet, Chennai-600 044.
Mobile: 94447 62797, 94446 42431,
Email: hansanbuilders@gmail.com

Yours faithfully
For HANSAN BUILDERS

PARTNER



PAAVAYEE CONSTRUCTIONS

BUILDERS & PROMOTERS,

DATE:13.07.2018

INTERNSHIP CERTIFICATE

This is to certify that Ms.ASMISHAHIN.A (RRN-150011601020) ,a student of B.E CIVIL ENGINEERING – Final year ,Crescent Institute Of Science And Technology, vandalur ,Chennai-600130 has successfully completed 31days (04.06.2018 to 19.06.2018) internship programme at this company. During the period of her internship programme with us she was found punctual, hard working and inquisitive.

We wish her every success in life.

Yours faithfully,

For PAAVAYEE CONSTRUCTIONS

M. K. K. K.

Proprietrix

Plot No. 7/51, Viswanathan Street, Radha Nagar,
Chromepet, Chennai - 600 044. Ph : 22652671

July 6, 2018

TO WHOMSOEVER IT MAY CONCERN

This is to certify that Ms S Suhasinee (Roll. No. 150011601107), pursuing third year B-Tech Civil Engineering in B S Abdur Rahman Crescent Institute of Science & Technology, Vandalur has undergone summer internship in the civil department of our organization, for a period from June 14 to July 7, 2018.

She exhibited good conduct and attitude during the internship.

We wish her all success in her future endeavors.

For Emerald Haven Realty Limited,

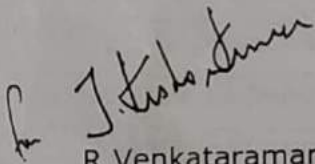
A handwritten signature in black ink, appearing to read "R Venkataramanan".

R Venkataramanan
General Manager - Civil

Emerald Haven Realty Ltd

Corporate Office : 1st Floor, Greenways Tower, 119, St. Mary's Road, Abhiramapuram, Chennai - 600 018.

Registered Office : Jayalakshmi Estates, No. 29, Haddows Road, Nungambakkam, Chennai-600 006.

T : (91) 44-2436 1261, E : corpssc@scl.co.in, W : www.tvsemerald.com

CIN : U45200TN2010PLC075953 GST : 33AACCH4288E1ZQ



Chennai Metro Rail Limited
(A Joint Venture of Govt. of India and Govt. of Tamil Nadu)

26/07/2018

TO WHOMSOEVER IT MAY CONCERN

This is to certify that Thiru. T.Sukhanthan from Crescent Institute of Science & Technology has done his In-plant Training in Chennai Metro Rail Limited from 18th June 2018 to 23rd June 2018.

During the training his conduct was good.

We wish him all the best for his better future.

S. Raghuzanan
26.07.2018
Assistant Manager (HR)



Swanag Infrastructures

No. 9, Vivekananda Street, Balaji Nagar, Ambattur, Chennai - 600 053.
Tel : 2616 4699, 26164039 E-mail : swanaag@yahoo.co.in
GSTIN : 33ABYFS8529H2ZE

Date : 15.07.2018

CERTIFICATE

This is certify that **SUMERA.J (RRN.150011601109)** studying in B.S.Abdur Rahman Crescent Institute of Science and Technology, Vandalur, Chennai - 600048 has attended training during the period from **June 11'2018 to July 11 '2018** during the training period he is fully involved in preparation of Site Work.

For SWANAG INFRASTRUCTURES

Authorised Signatory



26th June, 2018

The Principal

Crescent Institute of Science & Technology

Seethakathi Estate, GST Road, Vandalur, Chennai-600130

Dear Sir,

Sub:- Internship Training

Please refer your College letter No. 107/Dean-SOI/06/18 dated 05.06.2018 and our letter dated 07.06.2018.

The following B.E. Civil Engineering final year Students of your college have successfully completed the Internship Training at this Organisation:-

Mr. THILAKESH M	-	RRN -150011601117
Mr. SYED ABBAS S.N.	-	RRN - 150011601111
Mr. THASLIM SHABIYA Z	-	RRN - 150011601136

Their Internship Training was commenced on 09.06.2018 and completed on 23.06.2018.

During their training period, we observed that they have shown keen interest in the Inplant Training.

We wish them all success in their future endeavours.

Yours faithfully,

For RUBY BUILDERS & PROMOTERS

DGM (Admin & Sales)



PAAVAYEE CONSTRUCTIONS

BUILDERS & PROMOTERS,

Date: 12.07.2018

INTERNSHIP CERTIFICATE

This is to certify that **MR.SYED ABBAS.S.N** (RRN – 150011601111) , a student of B.E CIVIL ENGINEERING – Final year ,Crescent Institute Of Science And Technology, vandalur ,Chennai-600130 has successfully completed 15 days (25.06.2018 to 09.07.2018) internship programme at this company. During the period of his internship programme with us he was found punctual, hard working and inquisitive.

We wish him every success in life.

Yours faithfully,

For **PAAVAYEE CONSTRUCTIONS**

M. Karunanidhi

Proprietor

Plot No. 7/51, Viswanathan Street, Radha Nagar,
Chromepet, Chennai - 600 044. Ph : 22652671



AMMA BUILDERS

Admn. Office : 7/4, Ramasamy Street,
Gopalapuram, Chennai - 600 014.
Phone : 044 42618118

DATE: 08-10 2018

TO WHOMSOEVER IT MAY CONCERN

This is to certify that Mr. SYED JUNAID FAKRUDDIN worked in our organization as implant trainee from 05th June to 05th July 2018. His duties included site managing. We found him sincere, hardworking, technically sound and result oriented. He worked well as part of the team during his tenure. We take this opportunity to thank him and wish him all the best for his future.

During the above period Mr. SYED JUNAID FAKRUDDIN has engaged in G+2 RESIDENTIAL PROJECT located at LAKSHMI NAGAR MAIN ROAD at KOLATHUR

For AMMA BUILDERS

(Mohammed Jameel Ahmed)
Managing Partner

Reg. Office : 2/34, R.O.B. 5th Street, Royapettah, Chennai - 600 014.



A.S. CONSTRUCTION

No.3/16B, Gandhi Nagar,
Periyar Salai, Palavakkam,
Chennai - 600 041.

Phone : 044 - 42855101
Mobile : 9941529066
asconstructionn@gmail.com

Date :

CERTIFICATE

This is certify that **Mr.SYED SAIFUDDIN** (RRN. 150011601113) studying in
B.S.Abdur Rahman Crescent Institute of Science and Technology, Vandalur, Chennai – 48
has attended training during the period from **12.06.2018** to **11.07.2018**. During the training
period he is fully involved in preparation of **Managing the Site work**.

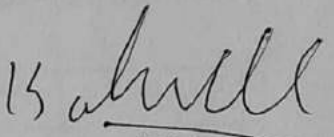
Signature / With seal

For A.S. CONSTRUCTION

Proprietor



A.S. CONSTRUCTION

No.3/16B, Gandhi Nagar,
Periyar Salai, Palavakkam,
Chennai - 600 041.

Phone : 044 - 42855101
Mobile : 9941529066
asconstructionn@gmail.com

Date :

INDUSTRIAL INTERNSHIP EVALUATION FORM

STUDENTS OF B.TECH. (CIVIL) B.S.ABDUR RAHMAN CRESCENT INSTITUTE OF SCIENCE
AND TECHNOLOGY

DATE:14.07.2018

Name of the Intern and : SYED SAIFUDDIN N
Reg. No : 150011601113
Father's Name : SYED NASIRUDDIN R
Branch : CIVIL ENGINEERING
Internship Offered : From: 12.06.2018 To: 11.07.2018

Evaluation of the Internship may be done with the following letter grades. The grade point for the letter grades is given below.

Grades	S (High)	A	B	C	D	E (Low)	U
Points	10	9	8	7	6	5	Unsatisfactor y

SL.NO.	PARAMETERS	Grade Awarded
1.	Knowledge Acquired During Internship	A
2.	Ability to use Techniques and Methods Appropriate for Assignments	A
3.	Ability to Display the Technical Skills required	A
4.	Ability to Organize, Classify and Deliver the job	A
5.	Perseverance to Complete the job	A
6.	Takes Initiative and Works with Minimal Supervision	A
7.	Attendance and Punctuality	S
8.	Ability to Establish Positive Relationships with the Manager and Peers	A
9.	Personal Conduct and Behaviour	A
10.	Ability to Cope Up with the Stressful Situations	A



A.S. CONSTRUCTION

No.3/16B, Gandhi Nagar,
Periyar Salai, Palavakkam,
Chennai - 600 041.

Phone : 044 - 42855101
Mobile : 9941529066
asconstructionn@gmail.com

Date :

11. Department (s) / Section (s) where the intern was accommodated:

SL.NO.	Department (s)/ Section(s)	Type of work	Period	
			From	To
1	CONSTRUCTION	REINFORCED CEMENT CONCRETE	12.06.2018	28.06.2018
2	CONSTRUCTON	BRICK WORK	29.06.2018	11.07.2018

12. Intern's Strength

: BRICK WORK

13. Areas for Improvement

: REINFORCED CEMENT CONCRETE

14. Additional Comments, if any

: GOOD IN GRASPING TECHNICAL DETAILS...

		Grade Awarded
15	Overall Evaluation of the Intern's Performance	A

P. Kasthick (Signature)
Name / Signature of Officer In- Charge (Training) :

13/07/18 (Signature)
Authorized Signatory

HPK STAR PROPERTY DEVELOPERS

Manjiyam Apartments, Flat No. B-1, No. 20, East Main Road, Gopal Reddy Colony, (Near Indian Bank Perambur Branch),
Chennai - 600 082. Ph : 42789040 Email : basheerccb@gmail.com

Date

CERTIFICATE

This is to certify that **Mr. T.K.MOHAME FAYAZUDEN (RRN. 150011601114)** studying in
B.S. Abdur Rahman Crescent Institute of Science and Technology, Vandalur, Chennai -48
Has attended training during the period from **07.06.2018 to 07.07.2018**. During the training
Period he is fully involved in preparation of Managing the site work.

Signature / with seal

For HPK Star Property Developers

Managing Partner



BUILT ON TRUST

ETA Properties and Investments Private Limited

CIN No.: U45202TN1996PTC051593

Regd Off: Chennai Citi Centre 4th floor, 10 & 11, Dr. Radhakrishnan Salai, Mylapore Chennai - 600 004.

Tel: + 91 - 44 - 4999 4999, 4999 4900, Fax: + 91 - 44 - 4357 7433

Email: chennai@etastar.co.in www.etastar.co.in

CERTIFICATE

This is certify that **Mr.Tauseef Ahamed R (RRN.150011601115)** studying in **B.S.Abdur Rahman Crescent Institute of Science and Technology, Vandalur,Chennai – 48** has attended training during the period **from 02.07.2018 to 14.07.2018**.during the training period he is fully involved in work of Site Engineer.

For ETA Properties and Investments Pvt.Ltd.

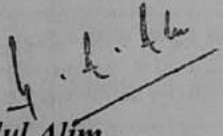
H.Abdul Alim
General Manager - HR





ASHA BUILDERS

BUILDERS & REAL ESTATE

No.243, Officers Line, Vellore - 632 001. Ph : 0416 - 2233786

Date :

CERTIFICATE

This is certify that Tauseef Ahamed R

(**RRN. 150011601115**) studying in B.S.Abdur Rahman Crescent
Insitute of Science and Technology, Vandalur, Chennai - 48 has
attended training during the period from **04/06/18 to 29/06/18**.

During the training period he is fully involved in preparation of
Repair of an old building .

For ASHA BUILDERS & REALESTATE

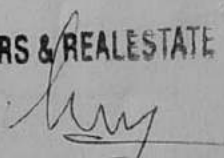
Signature / With seal



ASHA BUILDERS

BUILDERS & REAL ESTATE

No.243, Officers Line, Vellore - 632 001. Ph : 0416 - 2233786

Date :

CERTIFICATE

This is certify that **Tauseef Ahamed R**

(**RRN. 150011601115**) studying in B.S.Abdur Rahman Crescent

Institute of Science and Technology, Vandalur, Chennai - 48 has

attended training during the period from **04/06/18 to 29/06/18**.

During the training period he is fully involved in preparation of

Repair of an old building .

For ASHA BUILDERS & REAL ESTATE

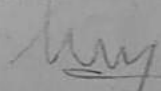
Signature / With seal

26th June, 2018

The Principal

Crescent Institute of Science & Technology

Seethakathi Estate, GST Road, Vandalur, Chennai-600130

Dear Sir,

Sub:- Internship Training

Please refer your College letter No. 107/Dean-SOI/06/18 dated 05.06.2018 and our letter dated 07.06.2018.

The following B.E. Civil Engineering final year Students of your college have successfully completed the Internship Training at this Organisation:-

Mr. THILAKESH M	-	RRN -150011601117
Mr. SYED ABBAS S.N.	-	RRN - 150011601111
Mr. THASLIM SHABIYA Z	-	RRN - 150011601136

Their Internship Training was commenced on 09.06.2018 and completed on 23.06.2018.

During their training period, we observed that they have shown keen interest in the Inplant Training.

We wish them all success in their future endeavours.

Yours faithfully,

For RUBY BUILDERS & PROMOTERS

DGM (Admin & Sales)



PAAVAYEE CONSTRUCTIONS
BUILDERS & PROMOTERS,

Date: 12.07.2018

INTERNSHIP CERTIFICATE

This is to certify that **MR.THILAKESH.M** (RRN – 150011601117) , a student of B.E CIVIL ENGINEERING – Final year ,**Crescent Institute Of Science And Technology**, vandalur ,Chennai-600130 has successfully completed 15 days (25.06.2018 to 09.07.2018) internship programme at this company. During the period of his internship programme with us he was found punctual, hard working and inquisitive.

We wish him every success in life.

Yours faithfully,

For **PAAVAYEE CONSTRUCTIONS**

M. Kannaiah

Proprietor

Plot No. 7/51, Viswanathan Street, Radha Nagar,
Chromepet, Chennai - 600 044. Ph : 22652671



EliteHomes

CONSTRUCTIONS

CERTIFICATE

This is to certify that **USAMA ZAID PL (RRN: 150011601118)** studying in B.S.Abdur Rahman Crescent Insitute of Science and Technology, Vandalur,Chennai – 48 has attended training during the period from 10-06-18 to 09-07-18. during the training period he is fully involved in preparation of **CONSTRUCTION MANAGEMENT AND ORGANIZING WORK .**

Elite Homes

892/CC, Weekly Market Road,
Khaderpet, Vaniyambadi-635751

S. R. G.
Signature / With seal

#892,Weekly market road khaderpet vaniyambadi-635751



Chennai Metro Rail Limited

(A Joint Venture of Govt. of India and Govt. of Tamil Nadu)

26/07/2018

TO WHOMSOEVER IT MAY CONCERN

This is to certify that Thiru. M.Vadivel Murugan from Crescent Institute of Science & Technology has done his In-plant Training in Chennai Metro Rail Limited from 18th June 2018 to 23rd June 2018.

During the training his conduct was good.

We wish him all the best for his better future.

S. Raghuraman
26.07.2018
Assistant Manager (HR)

CMRL Depot, Admin Building, Poonamallee High Road, Koyambedu, Chennai - 600 107.

Phone : 23792000 Fax : 23792200

E-mail : chennaietrorail@cmrl.in website : www.chennaietrorail.org

CIN : U60100TN2007SGC065596



Chennai Metro Rail Limited

(A Joint Venture of Govt. of India and Govt. of Tamil Nadu)

26/07/2018

TO WHOMSOEVER IT MAY CONCERN

This is to certify that Thiru. Vimal Raj from Crescent Institute of Science & Technology has done his In-plant Training in Chennai Metro Rail Limited from 18th June 2018 to 23rd June 2018.

During the training his conduct was good.

We wish him all the best for his better future.

S. Raghuraman
26.07.2018
Assistant Manager (HR)

CMRL Depot, Admin Building, Poonamallee High Road, Koyambedu, Chennai - 600 107.
Phone : 23792000 Fax : 23792200
E-mail : chennaietrorail@cmrl.in website : www.chennaietrorail.org
CIN : U60100TN2007SGC065596



+91 99440 39736
+91 90805 75756

A-ONE BUILDERS

PLAN | ESTIMATE | CONSTRUCTION | CIVIL CONSULTANT

No.20, Ramasamy Desigar Street, Salavanpet, Vellore - 632 001.
E-mail : a1builders.vlr@gmail.com

Date : 05-07-2018

TO WHOMSOEVER IT MAY CONCERN

This is to certify that **Mr.J Ziaudeen Ashfaq** working in our organization, as **Inplant Training** from 05th June 2018 to 05th July 2018. His duties included working site managing. We found him sincere, hardworking, technically sound and result oriented. He worked well as part of a team during his tenure. We take this opportunity to thank him and wish him all the best for his future.

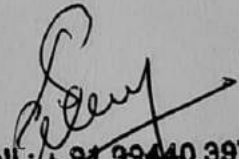

During the above period **Mr.J Ziaudeen Ashfaq** has engaged in G+1 Residential project works at Salavanpet, Vellore District.

Cell: + 91 99440 39739
A-ONE BUILDERS
Civil Engineering Consultant
No. 20, Ramasamy Desigar Street,
Salavanpet, Vellore - 632 001.



+91 99440 39736
+91 90805 75756

A-ONE BUILDERS

PLAN | ESTIMATE | CONSTRUCTION | CIVIL CONSULTANT

No.20, Ramasamy Desigar Street, Salavanpet, Vellore - 632 001.
E-mail : a1builders.vlr@gmail.com

Date : 05-07-2018

TO WHOMSOEVER IT MAY CONCERN

This is to certify that **Mr.J Ziaudeen Ashfaq** working in our organization, as **Inplant Training** from 05th June 2018 to 05th July 2018. His duties included working site managing. We found him sincere, hardworking, technically sound and result oriented. He worked well as part of a team during his tenure. We take this opportunity to thank him and wish him all the best for his future.

During the above period **Mr.J Ziaudeen Ashfaq** has engaged in G+1 Residential project works at Salavanpet, Vellore District.

Call : + 91 99440 39739
A-ONE BUILDERS
Civil Engineering Consultant
No. 20, Ramasamy Desigar Street,
Salavanpet, Vellore - 632 001.



AMMA BUILDERS

Admn. Office : 7/4, Ramasamy Street,
Gopalapuram, Chennai - 600 014.
Phone : 044 42618118

DATE: 08-10 2018

TO WHOMSOEVER IT MAY CONCERN

This is to certify that Mr. N MOHAMMED HARIS ABDULLAH worked in our organization as implant trainee from 05th June to 05th July 2018. His duties included site managing. We found him sincere, hardworking, technically sound and result oriented. He worked well as part of the team during his tenure. We take this opportunity to thank him and wish him all the best for his future.

During the above period Mr. N MOHAMMED HARIS ABDULLAH has engaged in G+2 RESIDENTIAL PROJECT located at LAKSHMI NAGAR MAIN ROAD at KOLATHUR

For AMMA BUILDERS

(Mohammed Jameel Ahmed)
Managing Partner



Swanag Infrastructures

No. 9, Vivekananda Street, Balaji Nagar, Ambattur, Chennai - 600 053.
Tel : 2616 4699, 26164039 E-mail : swanaag@yahoo.co.in
GSTIN : 33ABYFS8529H2ZE

Date : 15.07.2018

CERTIFICATE

This is certify that **MATHAN KUMAR.R (RRN.1500116011231)** studying in B.S.Abdur Rahman Crescent Institute of Science and Technology, Vandalur, Chennai - 600048 has attended training during the period from **June 11'2018 to July 11 '2018** during the training period he is fully involved in preparation of Site Work.

For SWANAG INFRASTRUCTURES

Authorised Signatory

26th June, 2018

The Principal

Crescent Institute of Science & Technology

Seethakathi Estate, GST Road, Vandalur, Chennai-600130

Dear Sir,

Sub:- Internship Training

Please refer your College letter No. 107/Dean-SOI/06/18 dated 05.06.2018 and our letter dated 07.06.2018.

The following B.E. Civil Engineering final year Students of your college have successfully completed the Internship Training at this Organisation:-

Mr. THILAKESH M	-	RRN -150011601117
Mr. SYED ABBAS S.N.	-	RRN - 150011601111
Mr. THASLIM SHABIYA Z	-	RRN - 150011601136

Their Internship Training was commenced on 09.06.2018 and completed on 23.06.2018.

During their training period, we observed that they have shown keen interest in the Inplant Training.

We wish them all success in their future endeavours.

Yours faithfully,

For RUBY BUILDERS & PROMOTERS

DGM (Admin & Sales)



CERTIFICATE

This is to certify that **SHAIK THANVEER NAZEEM** (RRN. **150011601148**) studying in B.S.Abdur Rahman Crescent Insitute of Science and Technology, Vandalur,Chennai – 48 has attended training during the period from 05/06/2018 to 06/07/2018. During the training period he is fully involved in preparation of **POLAVARAM IRRIGATION PROJECT RIGHT MAIN CANAL –PACKAGE -IV, BHIMADOLE, WEST GODAVARI DISTRICT, ANDHRA PRADESH, INDIA.**

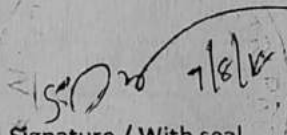
Signature / With seal

Regd. & Corp. Office :

Gayatri Projects Limited, B1, 6-3-1090, TSR Towers
Raj Bhavan Road, Somajiguda, Hyderabad 500 082, T.S
CIN: L99999TG1989PLC057289

T +91 40 2331 0330 /4284 /4296
F +91 40 2339 8435

E gplhyd@gayatri.co.in
www.gayatri.co.in

CERTIFICATE

This is certify that **SALMAN FARSI A (RRN.150011601092)** studying in (B.Tech Civil Engg) B.S.Abdur Rahman Crescent Insitute of Science and Technology, Vandalur,Chennai – 48 has attended training during the period from 05-06-2018 to 07-07-2018. during the training period he is fully involved in preparation of Estimate, Construction and Supervision Works.



Wahid
GENERAL MANAGER



Chennai Metro Rail Limited

(A Joint Venture of Govt. of India and Govt. of Tamil Nadu)

26/07/2018

TO WHOMSOEVER IT MAY CONCERN

This is to certify that Thiru. R.Sathish Kumar from Crescent Institute of Science & Technology has done his In-plant Training in Chennai Metro Rail Limited from 18th June 2018 to 23rd June 2018.

During the training his conduct was good.

We wish him all the best for his better future.

S. Raghu Ramar
26.07.2018
Assistant Manager (HR)

CMRL Depot, Admin Building, Poonamallee High Road, Koyambedu, Chennai - 600 107.

Phone : 23792000 Fax : 23792200

E-mail : chennaietrorail@cmrl.in website : www.chennaietrorail.org

CIN : U60100TN2007SGC065596



Chennai Metro Rail Limited

(A Joint Venture of Govt. of India and Govt. of Tamil Nadu)

26/07/2018

TO WHOMSOEVER IT MAY CONCERN

This is to certify that Thiru. R.Sathish Kumar from Crescent Institute of Science & Technology has done his In-plant Training in Chennai Metro Rail Limited from 18th June 2018 to 23rd June 2018.

During the training his conduct was good.

We wish him all the best for his better future.

S. RaghuRaman
26.07.2018
Assistant Manager (HR)

CMRL Depot, Admin Building, Poonamallee High Road, Koyambedu, Chennai - 600 107.

Phone : 23792000 Fax : 23792200

E-mail : chennaietrorail@cmrl.in website : www.chennaietrorail.org

CIN : U60100TN2007SGC065596



Chennai Metro Rail Limited
(A Joint Venture of Govt. of India and Govt. of Tamil Nadu)

26/07/2018

TO WHOMSOEVER IT MAY CONCERN

This is to certify that Thiru. S.Santhosh from Crescent Institute of Science & Technology has done his In-plant Training in Chennai Metro Rail Limited from 18th June 2018 to 23rd June 2018.

During the training his conduct was good.

We wish him all the best for his better future.

S. Raghunamar
26.07.2018
Assistant Manager (HR)



Chennai Metro Rail Limited

(A Joint Venture of Govt. of India and Govt. of Tamil Nadu)

26/07/2018

TO WHOMSOEVER IT MAY CONCERN

This is to certify that Thiru. S.Santhosh from Crescent Institute of Science & Technology has done his In-plant Training in Chennai Metro Rail Limited from 18th June 2018 to 23rd June 2018.

During the training his conduct was good.

We wish him all the best for his better future.

S. Raghunathan
26.07.2018
Assistant Manager (HR)

CMRL Depot, Admin Building, Poonamallee High Road, Koyambedu, Chennai - 600 107.

Phone : 23792000 Fax : 23792200

E-mail : chennaietrorail@cmrl.in website : www.chennaietrorail.org

CIN : U60100TN2007SGC065596

JAZ BUILDER
56/23C, Kattubava Pallivasal Street
Tenkasi-627811

Cell No: 9486322351
Ph:04633 225351

CERTIFICATE

This is certify that **MOHAMMED USMAN SHAREEF.M (RRN. 150011602013)** studying in B.S.Abdur Rahman Crescent Insitute of Science and Technology, Vandalur,Chennai – 48 has attended training during the period from **05/06/2018** to **06/07/2018**. during the training period he is fully involved in preparation of **RESIDENTIAL BUILDING PROJECT IN, TENKASI - 627811.**
TIRUNELVELI DIST, TAMILNADU, INDIA.

For JAZ BUILDERS

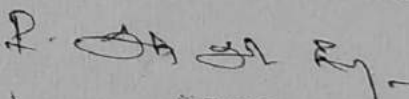
PROPRIETOR
Signature / With seal

MAGESHWARI CONSTRUCTION

S.SATHESH, B.E., P.D.Q.S.,

Engineer, Contractor & Licensed Surveyor

Office: 13, Jigini Plaza, Pillayar Kulam Street, (Inside New Bus Stand)

Chengalpattu – 603 001.

Cell: 98426 98276

IN-PLANT TRAINING CERTIFICATE

This is to certify that **N. SATHISH KUMAR**, Roll no. **150011601096**, pursuing B.E., FINAL YEAR Civil Engineering Department at Crescent Institute of Science and Technology, Vandalur, has undergone In-Plant Training in our concern between **05th JUNE to 04th JULY 2018**.

In these Periods, him performance, involvement and enthusiasm and also him Contact and Character were Very Good.

Regards,

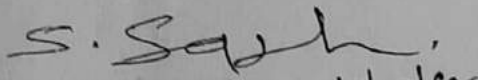

(S.SATHESH)

10/07/18

**PROPRIETOR,
MAGESHWARI CONSTRUCTIONS,
CHENGALPATTU.**

**S. SATHESH, B.E., P.D.Q.S.,
ENGINEER CONTRACTOR,
LICENSED SURVEYOR,**

M/s MAGESHWARI CONSTRUCTION

**No. 13, Jigini Plaza, Pillayarkulam St,
Chengalpattu - 603 001.**

DATE:13.07.2018

INTERNSHIP CERTIFICATE

The following B.E Civil engineering students of **BSA Crescent Institute Of Science and Technology** have successfully completed the Internship training at this company:-

Mr.RAMKUMAR.J	-RRN 150011601085
Mr.RAMKUMAR.S	-RRN 150011601086
Mr.RIYAZ AHAMED.P.M	-RRN 150011601089
Mr.SREERAJ.P	-RRN 150011601104

Their internship was commenced on **12.06.2018** and completed on **13.07.2018**.

During their training period, we observed that they have shown keen interest in the implant training.

Yours faithfully,

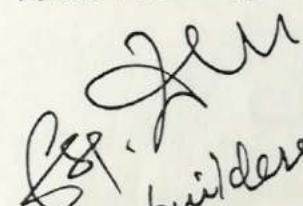
for Jetta Builders Pvt.

25-July-2018

TO WHOMSOEVER IT MAY CONCERN

This is to certify that **Ms. Sharumathi.E (Reg No: 150011601103)** Crescent Institute Of Technology - Chennai) has undergone internship with Casa Grande Civil Engineering Private Limited from **20/06/2018** to **02/07/2018** in Our Bloom Project – Thirumudivakkam, Chennai.

For Casa Grande Civil Engineering Private Limited

Anand S

Vice President – Human Resources

Date 23/06/2018

TO WHOM IT MAY CONCERN

This is certify that SHABAZ HUSSAIN . A (RRN- 150011601100) studying in B.S.Abdur Rahman Crescent Insitute of Science and Technology, Vandalur,Chennai – 48 has attended the inplant training during the period from 8-06-2018 to 22-06-2018 during the training period he is fully involved in preparation of Lions Blood Bank.

Hussian bilders

HUSSAIN BUILDERS
No. 68, L.B. ROAD,
ADYAR, CHENNAI - 600 020.
Signature / With seal

CASAGRAN

01 Nov 2018

TO WHOMSOEVER IT MAY CONCERN

This is to certify that Mr. Shaban Muxam (Reg No: 15511001100) Everett Engineering College (Chennai) has undergone inplant training with Casa Grande Civil Engineering Private Limited from 20/08/2018 to 14/09/2018 in the ECR-14 Project - Mysore, Chennai.

For Casa Grande Civil Engineering Private Limited



Anand S

Vice President - Human Resources

Megha Engineering & Infrastructures Ltd.

An ISO 9001-2008 Company

S-2, Technocrat Indl. Estate, Balanagar, Hyderabad-500037, Telangana, INDIA
Tel: +91-40-44336700 Fax: +91-40-44336800
E-mail: info@meil.in Visit us: www.meil.in U45202TG2006PLC050271

CERTIFICATE

This is certify that SHAIK SHAKEEL (RRN.150011601101) studying in
B.S.Abdur Rahman Crescent Insitute of Science and Technology, Vandalur, Chennai - 48 has
attended training during the period from 04/06/2018 to 06/07/2018.
During the training period he is fully involved in preparation of **Water Treatment Plant**,
Sangam, Nellore district, AP.

Md. Tufan
Signature / With seal





**BHARAT ENGINEERING
CONSTRUCTION COMPANY (P) LTD**

No. 1A, 'Jhaver Plaza', 6th Floor,
Nungambakkam High Road,
Nungambakkam, Chennai - 600 034.
Tel : 4214 4210, 2827 3317 / 18 / 19
Fax : 044 4214 4209
email: bharat@becc.in
Web : www.becc.in
CIN : U45201TN2006PTC059738

10/07/2018

TO WHOMSOEVER IT MAY CONCERN

This is to certify that **Mr. Seyed Ahamed Mohideen Thamby**, (Roll. No. 150011601099) is doing B.E. (Civil Engineering) final Year in Crescent Institute of Science & Technology, Vandalur, Chennai. has under gone a Inplant Training in Construction of Grade Separator Site at Irattai Eri, Kolathur, & Construction of Grade Separator Site at Pallavaram, Chennai of our concern from 25th June, 2018 to 10th July, 2018 satisfactorily. During the Course of training he was sincere, committed and showed immense interest in learning the work.

For Bharat Engineering Construction Company P. Ltd.,

12/7/18



General Manager



SMART
Constructions

04.11.2018

This is to certify that **Mr. SEYED AHAMED MOHIDEEN THAMBY**, Regn. No. 150011601099 studying at B. S. Abdur Rahman Crescent Institute of Science and Technology, Vandalur, Chennai – 600 048 has attended training during the period from 10.06.2018 to 24.06.2018

He has found to be good, punctual and observant during training period.

SMART CONSTRUCTION
99, B, Kuthukkal Street
KAYALPATNAM 623 204
Tamil Nadu

F. Mohamed

Signature with Seal

249 / 99B, Kuthukal Street,
Kayalpatnam, Tutucorin District,
Tamilnadu - 628204,
India.

T: (+91) 87782 12982
(+91) 96003 92659
(+91) 98940 30909

info@smarteverything.in
www.smarteverything.in



SMART
Everything

Date: 07.07.2018
Chennai

INPLANT TRAINING CERTIFICATE

This is to certify that Mr. PB. SANTHOSH KUMAR S/o Mr. P.BABU doing his B-Tech – civil engineering at CRESENT INSITUTE OF SCIENCE AND TECHNOLOGY VANDALUR, CHENNAI, he has under gone Inplant training from 04th JUNE 2018 to 6th JULY 2018. During which he has learned about various practical aspects of site Advanced Construction in our EMPIRE PRECAST factory at Konganacheri Village Palur post, Chengalpattu Tk, kanchipuram Dt, PIN – 603101.



C: 044 2226 1685, +91 93853 19
W: www.empireprecast.in , e: empireprecast@yahoo.
A: #13, 7th Street, Krishna nagar, West Tambaram, Chennai - 600



MG BUILDERS

☎ : 2551526

No.11, Alagar Nagar, N.G.O. 'A' Colony, Tirunelveli - 7.
Website : www.mgbuilders.in E-mail : mgbuildersvms@yahoo.com

Date: 12.7.18

CERTIFICATE

This is certify that N.SAMEER AHMED (RRN. 150011601093) studying in B.S.Abdur Rahman Crescent Insitute of Science and Technology, Vandalur, Chennai - 48 has attended training during the period from 12.6.18 to 12.7.18, during the training period he is fully involved in preparation of Site Engineer.

Signature / With Seal.
For MG BUILDERS

M. Nallanayyan
Proprietrix

DATE:13.07.2018

INTERNSHIP CERTIFICATE

The following B.E Civil engineering students of **BSA Crescent Institute Of Science and Technology** have successfully completed the Internship training at this company:-

Mr.RAMKUMAR.J -RRN 150011601085

Mr.RAMKUMAR.S -RRN 150011601086

→ Mr.RIYAZ AHAMED.P.M -RRN 150011601089

Mr.SREERAJ.P -RRN 150011601104

Their internship was commenced on **12.06.2018** and completed on **13.07.2018**.

During their training period, we observed that they have shown keen interest in the implant training.

Yours faithfully,

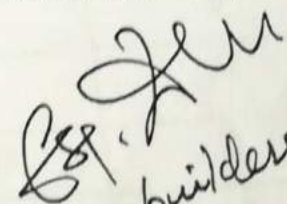
for Jettaa builders Pvt

Mangalam Constructions

Civil Engineering Contractor

4, Pillaiyar Kovil North Street, Nannilam,
Thiruvavarur - 610 105.

E-mail ID - rmangalamconstructions@yahoo.com

INDUSTRIAL INTERNSHIP EVALUTION FORM

STUDENTS OF B.TECH. (CIVIL) B.S ABDUR RAHMAN CRESCENT INSTITUTE OF SCIENCE AND TECHNOLOGY

Name of the Intern : REYAZ MOHAMED. L

Reg. No : 150011601088

Father's Name : N. LIYAKATH ALI

Branch : Civil

Internship Offered : Mangalam Construction From 05.06.18 To 06.07.18

Evaluation of the Internship may be done with the following letter grades. The grade point for the letter grades is given below.

Grades	S (High)	A	B	C	D	E (Low)	U
Points	10	9	8	7	6	5	Unsatisfactory

S.No	PARAMETERS	Grade Award
1	Knowledge Acquired During Internship	A
2	Ability to use Techniques and Methods Appropriate for Assignments	A
3	Ability to Display the Technical Skills required	A
4	Ability to Organize, Classify and Deliver the job	A

Mangalam Constructions

Civil Engineering Contractor

4, Pillaiyar Kovil North Street, Nannilam,
Thiruvarur - 610 105.

E-mail ID - rmangalamconstructions@yahoo.com

CERTIFICATE

This is certificate that REYAZ MOHAMED. L (Reg. No: 150011601088) studying in B.S. Abdur Rahman Crescent Institute of Science and Technology, Vandalur, Chennai - 48 has attended training during the period from 5.6.18 to 6.07.18, during the training period he is fully involved in preparation of Site Engineers.

For Mangalam Construction

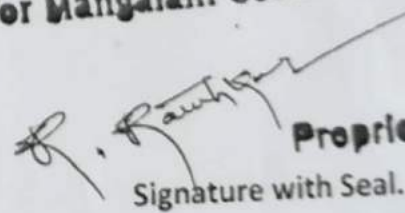
Proprietor

Signature with Seal.

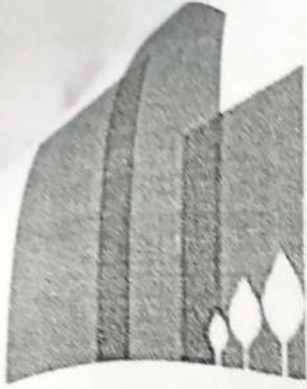

Mangalam Constructions

GST No.33BJQPS4093B2Z0
Mobile : 9443973337

Civil Engineering Contractor
4, Pillaiyar Kovil North Street, Nannilam,
Thiruvarur - 610 105.
E-mail ID - rmangalamconstructions@yahoo.com

CERTIFICATE

This is certificate that **RAMPRASATH. T** (Reg. No: 150011601087) studying in B.S. Abdur Rahman Crescent Institute of Science and Technology, Vandalur, Chennai – 48 has attended training during the period from 05.06.18 to 06.07.2018, during the training period he is fully involved in preparation of Site Engineer.

For Mangalam Construction's

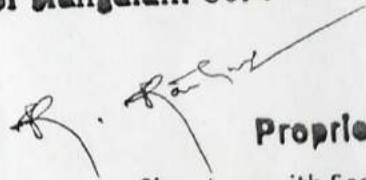
Proprietor.
Signature with Seal.

DATE:13.07.2018

INTERNSHIP CERTIFICATE

The following B.E Civil engineering students of **BSA Crescent Institute Of Science and Technology** have successfully completed the Internship training at this company:-

Mr.RAMKUMAR.J -RRN 150011601085

→ Mr.RAMKUMAR.S -RRN 150011601086

Mr.RIYAZ AHAMED.P.M -RRN 150011601089

Mr.SREERAJ.P -RRN 150011601104

Their internship was commenced on **12.06.2018** and completed on **13.07.2018**.

During their training period, we observed that they have shown keen interest in the implant training.

Yours faithfully,

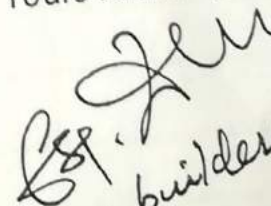
for Jettas builders P.



Chennai Metro Rail Limited

(A Joint Venture of Govt. of India and Govt. of Tamil Nadu)

26/07/2018

TO WHOMSOEVER IT MAY CONCERN

This is to certify that Thiru. D.Raghul from Crescent Institute of Science & Technology has done his In-plant Training in Chennai Metro Rail Limited from 18th June 2018 to 23rd June 2018.

During the training his conduct was good.

We wish him all the best for his better future.

S. Raghuraman
26.07.2018
Assistant Manager (HR)

July 6, 2018

TO WHOMSOEVER IT MAY CONCERN

This is to certify that Ms B Radhika (Roll. No. 150011601083), pursuing third year B-Tech Civil Engineering in B S Abdur Rahman Crescent Institute of Science & Technology, Vandalur has undergone summer internship in the civil department of our organization, for a period from June 14 to July 7, 2018.

She exhibited good conduct and attitude during the internship.

We wish her all success in her future endeavors.

For Emerald Haven Realty Limited,

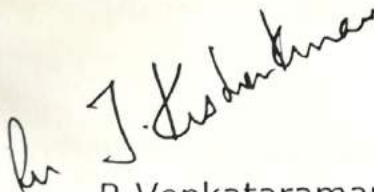
A handwritten signature in black ink, appearing to read "R Venkataramanan".
R Venkataramanan
General Manager - Civil

Emerald Haven Realty Ltd

Corporate Office : 1st Floor, Greenways Tower, 119, St. Mary's Road, Abhirampuram, Chennai - 600 018.
Corporate Office : 1st Floor, Greenways Tower, 119, St. Mary's Road, Nungambakkam, Chennai-600 006.

CERTIFICATE dated 9-july-2018

This is to certify that Monisha.A (RRN. 150011601074) studying in B.S.Abdur Rahman Crescent Institute of Science and Technology, Vandalur, Chennai – 48 has attended training in Kuwait at our office and workshop during the period from **3-6-2018 to 28-6-2018**.

During the training period she was fully involved in preparation execution of experiments in civil engineering laboratory and was involved in preparation of experimental reports at our training facility in

Kuwait

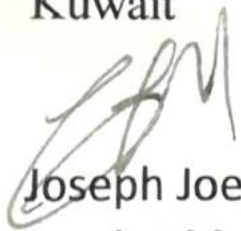

Joseph Joe Suther
Service Manager
Lab, science and technology division
Al Arfaj Engineering WLL





PAAVAYEE CONSTRUCTIONS
BUILDERS & PROMOTERS,

DATE:13.07.2018

INTERNSHIP CERTIFICATE

This is to certify that **Ms.SHARUMATHI.E (RRN-150011601103)**, a student of B.E CIVIL ENGINEERING – Final year, **Crescent Institute Of Science And Technology**, vandalur, Chennai-600130 has successfully completed 31 days (**04.06.2018 to 19.06.2018**) internship programme at this company. During the period of her internship programme with us she was found punctual, hard working and inquisitive.

We wish her every success in life.

Yours faithfully,

FOR PAAVAYEE CONSTRUCTIONS

M. Kavayal

Proprietrix

Plot No. 7/51, Viswanathan Street, Radha Nagar,
600130

VASANTH PLANNERS & DESIGNERS

Er.K.BABU, B.E., M.Sc., (Valuation)
Er.K.VIJAYABANU, M.Tech., MBA., M.Sc., (Valuation)
Licenced Building Surveyors

Office :

#13-V.C.M. Street, K.V.S.Complex (1st Floor)
(Opp.to New Bus Stand)
Tirupattur - 635 601, Vellore Dist.
Cell : 94862 81975, 94869 66002, 94868 49126
Ph : 04179 - 221975



We Undertake : Building Plans, Designs, Estimates, Lay - Out, Supervising etc...
(All are done in computer as per the Vasthu Sashtira)

CERTIFICATE

This is to certify that **SUFIYAN AHMED JEDDY** (RRN: 150011601105) studying in B. S. Abdur Rahman Crescent Institute of Science and Technology, Vandalur, Chennai - 48 has attended training during the period from 06/06/2018 to 08/07/2018. During the training period he is fully involved in

AutoCad drawing work.

K. V. H. 0.7.18.
Er. K. VIJAYA BANU
M.Tech., MBA., M.Sc. (Valuation)
Licensed Civil Engineer & Valuer
Vasanth Planners & Designers
13-E, V.C.M. Street, 1st Floor,
(Near Bus Stand)
TIRUPATTUR-635 601, Vellore Dt.
Cell: 94869 66002, 94862 81975

Signature / With seal



EliteHomes

CONSTRUCTIONS

CERTIFICATE

This is to certify that **MD ATHER K (RRN: 150011601044)** studying in B.S.Abdur Rahman Crescent Insitute of Science and Technology, Vandalur,Chennai – 48 has attended training during the period from 10-06-18 to 09-07-18. during the training period he is fully involved in preparation of **CONSTRUCTION MANAGEMENT AND ORGANIZING WORK**.

Elite Homes
892/12, Weekly Market Road,
Khaderpet, Vaniyambadi-635751
S. Pity
Signature / With seal

#892,Weekly market road khaderpet vaniyambadi-635751

Om Rajeswari Homes

We Construct New House with Vasthu Sasthiram

No. 2/239A, Anna Street, Vengalvasal Main Road, Santhoshapuram,
Chennai - 600 073.

Cell : 9382295310, 9940616546

11.06.18

Date.....

CERTIFICATE

Certified that Mr.A. ARUN, first year student of M.Tech (construction engineering & project management) in crescent institute of science and technology, Chennai, has attended In-plant training in our concern for the duration of 05.06.18 to 09.06.18

His conduct and character are good

For OM RAJESWARI

N. Arimurthi

Proprietor



harmony
homes with style

HARMONY RESIDENCES PRIVATE LIMITED

CIN : U45200TN2007PTC062379

tel: 4359 7400 / 7500 / 7600

"dal prasad", no.11, (old no. 42), 12th avenue, ashok nagar, chennai - 83.

21/9/2018

CERTIFICATE

This is certify that **R.BALA KEERTHANA (172202601002)** studying in B.S.Abdur Rahman Crescent Insitute of Science and Technology, Vandalur, Chennai – 48 has attended training during the period from **11.6.18 to 16.6.18** and from **25.6.18 to 4.7.18** during the training period She is fully involved in preparation of QUANTITY SURVEYING, DPR, PURCHASING ORDER, SCHEDULING AND SO ON.

For Harmony Residences Pvt.Ltd.

(S.Ramakrishnan)

Director

21/9/2018

CERTIFICATE

This is to certify that **B.DHEEPIKA LAKSHMI** (RRN. 172202601004) studying in B.S.Abdur Rahman Crescent Insitute of Science and Technology, Vandalur,Chennai – 48 has attended training during the period from **11-06-2018 to 16-06-2018** and from **25-06-2018 to 4-07-2018** during the training period she is fully involved in preparation of **QUANTITY SURVEYING , SCHEDULING , PREPARATION OF COMPARATIVE STATEMENT FOR PURCHASE ORDER , DPR ..ETC.**

For Harmony Residences Pvt.Ltd.



(S.Ramakrishnan)

Director

Om Rajeswari Homes

We Construct New House with Vasthu Sasthiram

No. 2/239A, Anna Street, Vengalvasal Main Road, Santhoshapuram,
Chennai - 600 073.

Cell : 9382295310, 9940616546

Date..... 11.06.18

CERTIFICATE

Certified that M. GANESH KUMAR, first year student of M.Tech (construction engineering & project management) in crescent institute of science and technology, Chennai, has attended In-plant training in our concern for the duration of 05.06.18 to 09.06.18

His conduct and character are good

For OM RAJESWARI HOMES
N. Ananthiah.
Inspector

வ.உ.சிதம்பரனார் துறைமுக பொறுப்புக் கழகம்

व.उ.चिदम्बरनार पत्तन न्यास

V.O. CHIDAMBARANAR PORT TRUST

கந்தி வ.உ.சிதம்பரனார் காமல், புறம்பு
தார வ.உ.சிதம்பரனார் பத்தன ந்யாச
GRAMS V.O. CHIDAMBARANAR PORT TRUST

தொலைபேசி } 2372999
தூய்மை / PHONE

தொலைபேசி அண் } 0461 - 2354270
பேச / FAX

website :
www.tuticorinport.gov.in
www.vocport.gov.in



மின்னஞ்சல் அஞ்சல் } info@tuticorinport.gov.in
E-Mail :

தூய்மை : 628 004
தூய்மை : 628 004
TUTICORIN : 628 004

CERTIFIED
UNDER ISO 9001:2008, ISO 14001:2004 &
ISPS COMPLIANT PORT

CIVIL ENGINEERING DEPARTMENT

सिविल इंजीनियरी विभाग

எண் / ச / No.

தேதி / தாரிச / Date

CERTIFICATE

This is to certify that Selvan.

P. Jeffreeves Ronald, M. Tech (Construction Engineering & Project Management) student of B.S.Abdur Rahman Crescent Institute of Science and Technology, Chennai has undergone Inplant training in Civil Engineering Department of V.O.Chidambaranar Port Trust, Tuticorin from 18.06.2018 to 02.07.2018. During the above period his Conduct and Character are good.

Selvan Immano
18/7
CHIEF ENGINEER i/c



Sri Surya Construction

📍 1/45, GNT Road, Sholavaram, Chennai - 600 067

📞 98416 66667 / 98416 89999 / 90926 89999

☎ 044 - 2633 0029

@ srisuryaconst@gmail.com

26.08.2018

CERTIFICATE

Certified that **Mr. R. MOHAMMED SAALIM**, Second year student of M. Tech (construction engineering & project management) BSA in Crescent Institute of Science & Technology, Chennai, has attended **In-Plant Training** in our concern for the duration of 10 days from 16-08-2018 to 26-08-2018

His conduct and character are good.

For SRI SURYA CONSTRUCTIONS
R. Anand

Proprietor

33AJGPA9857Q1ZL

CERTIFICATE

This is certify that M.KALIL RAHUMAN (RRN. 172202601009) studying in B.S.Abdur Rahman Crescent Institute of Science and Technology, Vandalur, Chennai – 48 has attended training during the period from 17/06/2018 to 10/7/2018. during the training period he is fully involved in preparation of RESIDENTIAL BUILDING OF (G+2).



For K.S.R. & Co.,

PARTNER.

Om Rajeswari Homes

We Construct New House with Vasthu Sasthiram

No. 2/239A, Anna Street, Vengalvasal Main Road, Santhoshapuram,
Chennai - 600 073.

Cell : 9382295310, 9940616546

Date..... 11.06.18

CERTIFICATE

Certified that Mr.N. MOHAMMED SALEEM BADHUSHA, first year student of M.Tech (construction engineering & project management) in crescent institute of science and technology, Chennai, has attended In-plant training in our concern for the duration of 05.06.18 to 09.06.18

His conduct and character are good

For OM RAJESWARI HOMES .

N. Arimulliah

proprietor

Om Rajeswari Homes

We Construct New House with Vasthu Sasthiram

No. 2/239A, Anna Street, Vengalvasal Main Road, Santhoshapuram,
Chennai - 600 073.

Cell : 9382295310, 9940616546

Date..... 11.06.18

CERTIFICATE

Certified that Mr.P.A. RAJA SELVA KUMAR, first year student of M.Tech (construction engineering & project management) in crescent institute of science and technology, Chennai, has attended In-plant training in our concern for the duration of 05.06.18 to 09.06.18

His conduct and character are good

For OM RAJESWARI HOMES

N. Arumuthiah

Proprietor

Om Rajeswari Homes

We Construct New House with Vasthu Sasthiram
No. 2/239A, Anna Street, Vengalvasal Main Road, Santhoshapuram,
Chennai - 600 073.

Cell : 9382295310, 9940616546

11.06.18

Date.....

CERTIFICATE

Certified that M. SANJAY RAJ, first year student of M.Tech
(construction engineering & project management) in crescent institute of
science and technology, Chennai, has attended In-plant training in our concern
for the duration of 05.06.18 to 09.06.18

His conduct and character are good

For OM RAJESWARI HOMES

N. Arimuliah
Proprietor

September 29th, 2018

TO WHOMSOEVER IT MAY CONCERN

This is to certify that **Mr. Deepak Balakumar**, student of M. Tech Construction Engineering & Project Management from Crescent Institute of Science & Technology had undergone internship at **IOCL Site, L&T GeoStructure**. The duration of the internship was from 18/06/2018 to 30/06/2018.

His conduct and performance during the training period was good.

Yours faithfully,
For L&T GEOSTRUCTURE



(Bino Mathew Jose)
Head Human Resources

- Er S.SURENDHAR BE
- Consulting engineer & L B S.

MUTHU CONSTRUCTION

NO:15 KUMARAN STREET SRINIVASAPURAM THIRUVARUR CELL:NO 8072216794

ISSUE:30-06-18

CERTIFICATE

This certify that C.SUDARSAN (RRN) studying in b.s abdur rahman cresent institute of science and technology Vadalur , Chennai -48 has attended training during the period from 12-06-18 – 30-06-18 during the training period be in fully involved in ROAD project.

Yours faithfully

For muthu constructions



S.SURENDHAR

CERTIFICATE

This is certify that S.DINESH (RRN. 172202601022) studying in B.S.Abdur Rahman Crescent Insitute of Science and Technology, Vandalur,Chennai – 48 has attended training during the period from 17/06/2018 to 10/7/2018.during the training period he is fully involved in preparation of RESIDENTIAL BUILDING OF (G+2).

Rs. Ganman

For K.S.R & Co.,

DATE: 10/7/2018

21/9/2018

CERTIFICATE

This is to certify that **B.DHEEPIKA LAKSHMI** (RRN. 172202601004) studying in B.S.Abdur Rahman Crescent Insitute of Science and Technology, Vandalur,Chennai – 48 has attended training during the period from **11-06-2018 to 16-06-2018** and from **25-06-2018 to 4-07-2018** during the training period she is fully involved in preparation of QUANTITY SURVEYING , SCHEDULING , PREPARATION OF COMPARATIVE STATEMENT FOR PURCHASE ORDER , DPR ..ETC.

For Harmony Residences Pvt.Ltd.

(S.Ramakrishnan)

Director

Sevvi Construction®

YOUR DREAMS INTO REALITY

R.SenthamizhSelvan, M.Tech

Managing Director

+9190039 35033

No.50, 1st Floor, E.C.R Road,
opp. to N.T.Mahal, Ellai pillai chavady
Puducherry - 605 005

Sevviconstruction@gmail.com

Certificate of experience

This is to certify that MS. Abinaya S(RRN:171202601001), studying M.Tech(Structural Engineering) in B.S.Abdur Rahman Institute of Science and Technology, Vandalur, Chennai-48 was undergone training from 5th june 2018 to 25th june 2018 .She has given training in AUTO CADD and STADD PRO .She has actively participated in structural design of an residential building.Her ability in designing and analysis is good.



(R.SENTHAMIZHSELVAN),M.Tech

Managing Director

SEVVI CONSTRUCTION
50, 1st Floor, ECR Road,
Opp To N.T Mahal,
Ellai pillai chavady Puducherry- 9.
Cell : 9003935033



Cell : 9840755055
9840107866
7010284866

ARNAULD BUILDERS

ARCHITECTS - ENGINEERS

R CLEMENT
Prop

Date : 09.07.2018

CERTIFICATE

This is to certify that **Mr. S.ARUN** (Reg. No.171202601002) studying I Year M.E. (STRUCTURAL ENGINEERING) in B.S. ABDUR RAHMAN CRESCENT INSTITUTE OF SCIENCE AND TECHNOLOGY, Vandalur, Chennai-48 has attended training during the period from 30.06.2018 to 09.07.2018 in our organization.

FOR ARNAULD BUILDERS

R. Clement
Proprietor



*Estimates, Plans,
Layouts, Constructions
and Documentation
Works
&
Supervisions*
REAL ESTATES



Off : 69-A/2, Kamarajar Street, (Singapore Seematty Backside)
Opp to Telegraph Office Kanchipuram.
Resi : 43, Lingappan Street, Kanchipuram - 631 502.

Cell : 98427 21499
94433 21499

J.Elangovan, D.C.E., Liv
Town Bank Panel Valuer,

Date...03/07/18.....

CERTIFICATE

This is to certify that **DIVYA.A (RRN:171202601003)** studying **M.Tech (Structural Engineering) regulation (2017 - 2019)** in B.S.Abdur Rahman Crescent Institute of Science and Technology, Vandalur, Chennai-48 has attended training during the period from **11th June 2018 to 3rd July 2018**. During the training period she is fully in preparation of following work:

1. Designed and analysed the G+1 residential building using CADD and STADD PRO software.
2. Designed and prepared the structural drawings for proposed convention hall.
3. Involved in the supervision of construction for a proposed Residential building.

**KANCHI BUILDERS,
43, LINGAPPAN STREET,
BIG KANCHIPURAM-631 502**



Estimates, Plans,
Layouts, Constructions
and Documentation
Works
&
Supervisions

REAL ESTATES



Off : 69-A/2, Kamarajar Street, (Singapore Seematty Backside)
Opp to Telegraph Office Kanchipuram.
Resi : 43, Lingappan Street, Kanchipuram - 631 502.

Cell : 98427 21499
94433 21499

J. Elangovan, D.C.E., Liv
Town Bank Panel Valuer,

Date... 05/07/18

TO WHOMSOEVER IT MAY CONCERN

This is to certify that Ms.J.DIVYA (RRN: 171202601004), studying M.Tech (Structural Engineering) regulation (2017 - 2019) in B.S.Abdur Rahman Crescent Institute of Science and Technology, Vandalur, Chennai-48 has attended training during the period from 11th June 2018 to 04th July 2018. During the training period she is fully involved in preparation of designing of building structures and detailing. Her ability in designing and analysis is good.

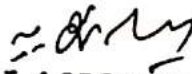
J. ELANGOVAN, D.C.E.,
LBS, Town Bank Panel Valuer,
43-B, Lingappan Street,
BIG KANCHIPURAM - 631 502.



Estimates, Plans,
Layouts, Constructions
and Documentation
Works
&
Supervisions

REAL ESTATES



Off : 69-A/2, Kamarajar Street, (Singapore Seematty Backside)
Opp to Telegraph Office Kanchipuram.
Resi : 43, Lingappan Street, Kanchipuram - 631 502.

Cell : 98427 21499
94433 21499

J.Elangovan, D.C.E., Liv
Town Bank Panel Valuer,

Date.....03/07/18

CERTIFICATE

This is to certify that **DYANESHWARAN.M (RRN:171202601005)** studying **M.Tech (Structural Engineering) regulation (2017 - 2019)** in **B.S.Abdur Rahman Crescent Institute of Science and Technology, Vandalur, Chennai-48** has attended training during the period from **11th June 2018 to 3rd July 2018**. During the training period he is fully in preparation of following work:

1. Designed and analysed the G+1 residential building using CADD and STADD PRO software.
2. Designed and prepared the structural drawings for proposed convention hall.
3. Involved in the supervision of construction for a proposed Residential building.

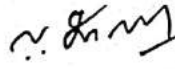
KANCHI BUILDERS,
43, LINGAPPAN STREET,
81G KANCHIPURAM-631 502



V.G. CONSTRUCTIONS

V. GANESAN
CONTRACTOR
CIVIL CONSTRUCTION

No.21, Navamani Street,
Central Bank Colony,
Chromepet, Chennai - 44.
Cell : 9444118728

Date.....20.06.2018

CERTIFICATE

This is to certify that **Mr. GREGORY MARIA CLINTON** (Reg. No. 171202601006) studying I Year M.E. (STRUCTURAL ENGINEERING) in B.S. ABDUR RAHMAN CRESCENT INSTITUTE OF SCIENCE AND TECHNOLOGY, Vandalur, Chennai-48 has attended training during the period from 05.06.2018 to 20.06.2018 in our organization.

For V.G. CONSTRUCTION

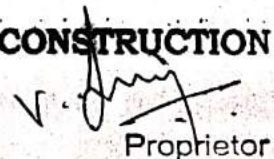
Proprietor



ARNAULD BUILDERS
ARCHITECTS - ENGINEERS

Cell :9840755055
9840107866
7010284866

R. CLEMENT
Prop

Date : 09.07.2018

CERTIFICATE

This is to certify that **Mr. GREGORY MARIA CLINTON** (Reg. No. 171202601006) studying 1 Year M.E. (STRUCTURAL ENGINEERING) in B.S. ABDUR RAHMAN CRESCENT INSTITUTE OF SCIENCE AND TECHNOLOGY, Vandalur, Chennai-48 has attended training during the period from 30.06.2018 to 09.07.2018 in our organization.

FOR ARNAULD BUILDERS

R. Clement
Proprietor



Cell :9840755055
9840107866
7010284866

ARNAULD BUILDERS

ARCHITECTS - ENGINEERS

R. CLEMENT
Prop

Date : 09.07.2018

CERTIFICATE

This is to certify that **Mr. C.JANARTHANAN** (Reg. No.171202601007) studying I Year M.E. (STRUCTURAL ENGINEERING) in B.S. ABDUR RAHMAN CRESCENT INSTITUTE OF SCIENCE AND TECHNOLOGY, Vandalur, Chennai-48 has attended training during the period from 30.06.2018 to 09.07.2018 in our organization.

FOR ARNAULD BUILDERS

R. Clement
Proprietor



V.G. CONSTRUCTIONS

V. GANESAN
CONTRACTOR
CIVIL CONSTRUCTION

No.21, Navamani Street,
Central Bank Colony,
Chromepet, Chennai - 44.
Cell : 9444118728

Date.....
20.06.2018

CERTIFICATE

This is to certify that **Mr. C.JANARTHANAN** (Reg. No.171202601007) studying I Year M.E. (STRUCTURAL ENGINEERING) in B.S. ABDUR RAHMAN CRESCENT INSTITUTE OF SCIENCE AND TECHNOLOGY, Vandalur, Chennai-48 has attended training during the period from 05.06.2018 to 20.06.2018 in our organization.

For V.G. CONSTRUCTION

V. Ganesh
Proprietor



Date: 20/06/2018

'8

CERTIFICATE

This is certify that Mr. R.JEEVA (RRN: 171202601008) Studying in B.S. Abdur Rahman Crescent Institute of Science and Technology, Vandalur, Chennai- 600 048. Has attended training during the period (From 4th June, 2018 to 20th June, 2018). During the training period he is fully involved in preparation of "DETAILED DESIGN CONSULTANCY WORK QUANTITY SURVEY, AUTOCAD PLAN, TRAFFIC ANALYSIS AND STRUCTURAL DRAWINGS. "

For Sonne Infrastructure Pvt Ltd

Authorized Signature





Date: 20/06/2018

CERTIFICATE

This is certify that Mr. R.JEEVA (RRN: 171202601008) Studying in B.S. Abdur Rahman Crescent Institute of Science and Technology, Vandalur, Chennai- 600 048. Has attended training during the period (From 4th June, 2018 to 20th June, 2018). During the training period he is fully involved in preparation of "DETAILED DESIGN CONSULTANCY WORK QUANTITY SURVEY, AUTOCAD PLAN, TRAFFIC ANALYSIS AND STRUCTURAL DRAWINGS."

For Sonne Infrastructure Pvt Ltd

Handwritten signature

Authorized Signature





Cell :9840755055
9840107866
7010284866

ARNAULD BUILDERS

ARCHITECTS - ENGINEERS

R. CLEMENT
Prop.

Date : 09.07.2018

CERTIFICATE

This is to certify that **Mr. A.KAJA MOHAMED HASEEF** (Reg. No.171202601009) studying I Year M.E. (STRUCTURAL ENGINEERING) in B.S. ABDUR RAHMAN CRESCENT INSTITUTE OF SCIENCE AND TECHNOLOGY, Vandalur, Chennai-48 has attended training during the period from 30.06.2018 to 09.07.2018 in our organization.

FOR ARNAULD BUILDERS

R. Clement
Proprietor



V.G. CONSTRUCTIONS

V. GANESAN
CONTRACTOR
CIVIL CONSTRUCTION

No.21, Navamani Street,
Central Bank Colony,
Chromepet, Chennai - 44.
Cell : 9444118728

Date.....
20.06.2018

CERTIFICATE

This is to certify that **Mr. A.KAJA MOHAMED HASEEF** (Reg. No.171202601009) studying I Year M.E. (STRUCTURAL ENGINEERING) in B.S. ABDUR RAHMAN CRESCENT INSTITUTE OF SCIENCE AND TECHNOLOGY, Vandalur, Chennai-48 has attended training during the period from 05.06.2018 to 20.06.2018 in our organization.

For V.G. CONSTRUCTION

V. 
Proprietor



V.G. CONSTRUCTIONS

V. GANESAN
CONTRACTOR
CIVIL CONSTRUCTION

No.21, Navamani Street,
Central Bank Colony,
Chromepet, Chennai - 44.
Cell : 9444118728

Date.....
20.06.2018

CERTIFICATE

This is to certify that **Mr. S.A.KARRTHIK** (Reg. No.171202601010) studying I Year M.E. (STRUCTURAL ENGINEERING) in B.S. ABDUR RAHMAN CRESCENT INSTITUTE OF SCIENCE AND TECHNOLOGY, Vandalur, Chennai-48 has attended training during the period from 05.06.2018 to 20.06.2018 in our organization.

For V.G. CONSTRUCTION

V. 
Proprietor



Cell :9840755055
9840107866
7010284866

ARNAULD BUILDERS

ARCHITECTS - ENGINEERS

R. CLEMENT
Prop

Date : 09.07.2018

CERTIFICATE

This is to certify that **Mr. S.A.KARRTHIK** (Reg. No.171202601010) studying 1
Year M.E. (STRUCTURAL ENGINEERING) in B.S. ABDUR RAHMAN CRESCENT
INSTITUTE OF SCIENCE AND TECHNOLOGY, Vandalur, Chennai-48 has attended
training during the period from 30.06.2018 to 09.07.2018 in our organization.

FOR ARNAULD BUILDERS
R. Clement
Proprietor



Sevvi Construction®

YOUR DREAMS INTO REALITY

Managing Director

+9190039 35033



No.50, 1st Floor, E.C.R Road,
opp. to N.T.Mahal, Ellaipillaichavady
Puducherry - 605 005



Sevviconstruction@gmail.com

Certificate of experience

This is to certify that **Mr.KISHOREKUMAR V(RRN:171202601011)** studying **M.Tech(Structural Engineering)** in **B.S.Abdur Rahman Institute of Science and Technology,Vandalur,Chennai-48** was undergone training from **5th june 2018 to 25th june 2018** .He has given training in **AUTO CADD** and **STADD PRO** .He has actively participated in structural design of an residential building.His ability in designing and analysis is good.

(R.SENTHAMIZHSELVAN),M.Tech

Managing Director

SEVVI CONSTRUCTION
50, 1st Floor, ECR Road,
Opp To N.T Mahal,
Ellaipillaichavady Puducherry- 9.
Cell : 9003935033



GSTIN: 33AAJFD2581J1ZE

Cell : 9994345366
9894122398
9944144387

DIVAGAR CONSTRUCTION

Regd. Office:

#72, Tamilnadu Housing Board,
Keelperumbakkam, Phase-1, Villupuram.-605602.

Branch:

#171/89, Second Street, South Kesava Perumalpuram,
Greems Road, Chennai-28.

E-mail : dharani0404@yahoo.com

Date: _____

25-07-2018

TO WHOMSOEVER IT MAY CONSERN

This is certify that N.MOHAMMED AMEERDEEN (171202601012) studying in B.S. Abdurrahman crescent institute of science and technology, Vandalur, Chennai-48. Has attend training during the period from 06-06-2018 to 23-06-2018. During the training period he is fully involved in preparation of designing of buildings and constructions. His ability in designing and analysis is good.

FOR DIVAGAR CONSTRUCTION

For DIVAGAR CONSTRUCTION.

K. Dhivul.

Partner.



GSTIN : 33AAJFD2581J1ZE

Cell : 9994345366
9894122398
9944144387

DIVAGAR CONSTRUCTION

Regd. Office:

#72, Tamilnadu Housing Board,
Keelperumbakkam, Phase-1, Villupuram.-605602.

Branch:

#171/89, Second Street, South Kesava Perumalpuram,
Greems Road, Chennai-28.

E-mail : dharani0404@yahoo.com

Date: _____

25-07-2018

TO WHOMSOEVER IT MAY CONSERN

This is certify that **N.MUTHUPANDI** (171202601013) studying in B.S.Abdur rahman crescent institute of science and technology, Vandalur, Chennai-48. Has attend training during the period from 06-06-2018 to 23-06-2018. During the training period he is fully involved in preparation of designing of buildings and constructions. His ability in designing and analysis is good.

FOR DIVAGAR CONSTRUCTION

For DIVAGAR CONSTRUCTION

K. Dhivul

Partner.

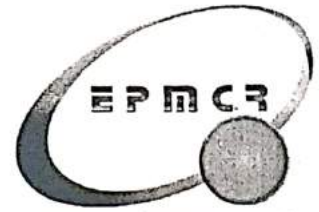

CREATING VALUES FOR YOUR INVESTMENT

An IIT Madras Incubated
Construction Technology Company

JULY 10, 2018

REF: EPMCRPL/18-19/INTERN/07-01

INTERNSHIP CERTIFICATE

Ms. Nandhini C, pursuing her Master of Technology in Structural Engineering (M.Tech) (Roll No: 171202601014) at B.S.Abdur Rahman Crescent Institute of Science and Technology, Vandalur, Chennai has completed internship training at our company, from June 11, 2018 to July 10, 2018.

Main Tasks accomplished:

1. Preparation of Bill of Quantities for Sodecia Compound wall and drain work.
2. Prepared detailed drawing of R.C.C Cover slab for the existing open well in the football ground of VCHS school for AMM foundation
3. Designed and Prepared the Structural Drawings for a residential building.

We found her sincere, hardworking, and technically sound and result oriented. She worked efficiently as part of a team during her tenure. We take this opportunity to thank her and wish her all the best in all her future endeavours.

FOR ENGINEERING PROJECT MANAGEMENT CONSULTANCY & RESEARCH PVT LTD.,

P.S. Muthu

MUKUNDAN P S
DIRECTOR



Engineering Project Management Consultancy and Research Private Limited



Regd. Office: #15, Rajamanickam Street, New Perungalathur, Chennai-600 063.
Tel : 044-4282 4759 | email : epmcr@epmcr.co.in | Web : www.epmcr.co.in





Surendra Infrastructure (P) Ltd.

19/1, V.I.P. ROAD, JUNGLI GHAT, PORTBLAIR-744 103, Q : 233517, FAX: 03192 - 231781

Email – sursale@yahoo.com

ADMN/PB/SPL

8th July 2018

To Whom So Ever It May Concern

This is to certify that Mr. NISHANT MALLICK (RRN- 171202601015) studying in B.S. Abdur Rahman Crescent Institute of Science and Technology, Vandalur, Chennai- 48 has attended training during the period from 5th JUNE 2018 to 5th JULY 2018 during the training period he was fully involved in designing of building and detailing at the site.

His ability in design aid is excellent.

Surendra Infrastructure Pvt. Ltd.

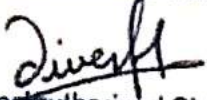
Director/Authorised Signatory

Surendra Infrastructure Pvt Ltd.



Estimates, Plans,
Layouts, Constructions
and Documentation
Works
&
Supervisions

REAL ESTATES



Off : 69-A/2, Kamarajar Street, (Singapore Seematty Backside).
Opp to Telegraph Office Kanchipuram.
Resi : 43, Lingappan Street, Kanchipuram - 631 502.

Cell : 98427 21499
94433 21499

J.Elangovan, D.C.E., Liv
Town Bank Panel Valuer,

Date.....03/07/18.....

CERTIFICATE

This is certify that **THRIBURASUNDHARY.L (RRN:171202601017)** studying **M.Tech (Structural Engineering) regulation (2017 - 2019)** in **B.S.Abdur Rahman Crescent Institute of Science and Technology, Vandalur, Chennai-48** has attended training during the period from **11th June 2018 to 3rd July 2018**. During the training period he is fully in preparation of following work:

1. Designed and analysed the G+1 residential building using CADD STADD PRO software.
2. Designed and prepared the structural drawings for proposed convention hall.
3. Involved in the supervision of construction for a proposed Residential building.

**KANCHI BUILDERS,
43, LINGAPPAN STREET,
KANCHIPURAM-631 502**

S.P.S. Inbarajan, M.E., A.M.I.E.,
Chief Consultant

BOURNA
CONSULTANTS-ENGINEERS

3rd JULY 2018

TO WHOMSOEVER IT MAY CONCERN

This is to certify that Mr.UMESH RAJAN J K (RRN:171202601018), studying in M.Tech(Structural Engineering) in B.S.Abdur Rahman Institute of Crescent Science & Technology, Vandalur, Chennai - 48 was undergone training from 5th June 2018 to 3rd July 2018.He has trained in designing of building structure and detailing. His ability in designing and analysis is good.

FOR BOURNA CONSULTANTS ENGINEERS,

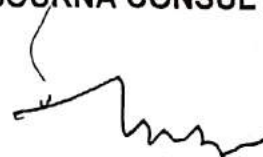

(S.P.S. INBARAJAN)

Chief Consultant.

S.P.S INBARAJAN

M.E.,(Structural) A.M.I.E.

Structural Consultant

Class-I, Licensed Surveyor

Corporation of Chennai No.1794/2017-2018

Door No.3, Flat No.G-2,

Ramakrishna Puram III Street,

West Mambalam, Chennai-600 033

From

M.SIVARAMAKRISHNA,
Head, ISS/SISD/EIG,
Indira Gandhi Centre for Atomic Research,
Department of Atomic Energy,
Kalpakkam.

To

M.BASHEER AHMED,
Head Of the Department,
Crescent Institute Of Science And Technology,
Vandalur,
Chennai.

Respected Sir,

Subject: ATTENDANCE REPORT

This is to certify that the following students were doing their project at ISS Laboratory, IGCAR, Kalpakkam from 20.03.19 to 15.04.19. This is for your kind perusal.

170572601003- HASIF ANSAR-

170572601005- S.KARTHICK

170572601009- R.PRIYA KADHAMBARI-

170572601011- A.UBAIYATHULLA-

THROUGH:

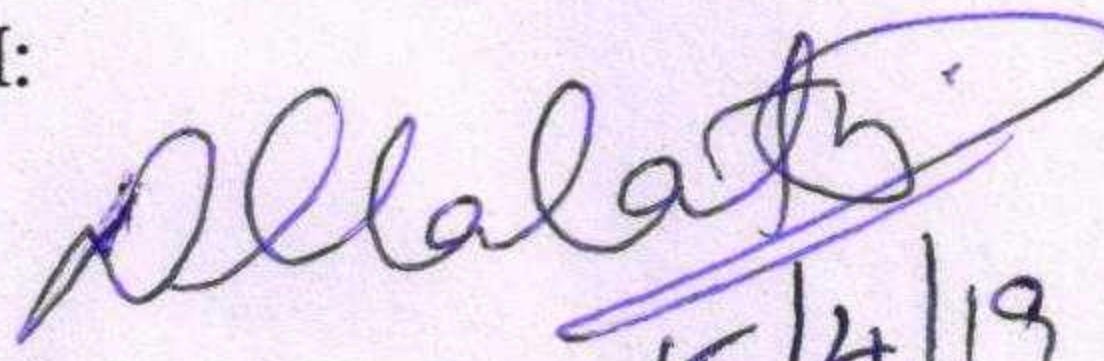
15/4/19
C.N. MALATHI, SO(E)
ISS/EIG/IGCAR

Regards,

Scientific Officer (E)
IIS, EG,
'Indira Gandhi Centre for Atomic Research'
Kalpakkam-603 102. Tamil Nadu.

From

M.SIVARAMAKRISHNA,
Head, ISS/SISD/EIG,
Indira Gandhi Centre for Atomic Research,
Kalpakkam.

To

M.BASHEER AHMED,
Head Of the Department,
Crescent Institute Of Science And Technology,
Vandalur,
Chennai.

Sir,

Subject: Attendance report of project students at ISS laboratory.

This is to certify that the following students are doing their project at ISS Laboratory, IGCAR, Kalpakkam from 08.01.19 till today (19-03-2019)

170572601003- HASIF ANSAR

170572601005- S.KARTHICK

170572601009- R.PRIYA KADHAMBARI

170572601011- A.UBAIYATHULLA

These students were present at our lab for 48 days out of 50 working days. This is for your kind perusal.

Recommended.  19/3/19

Through:

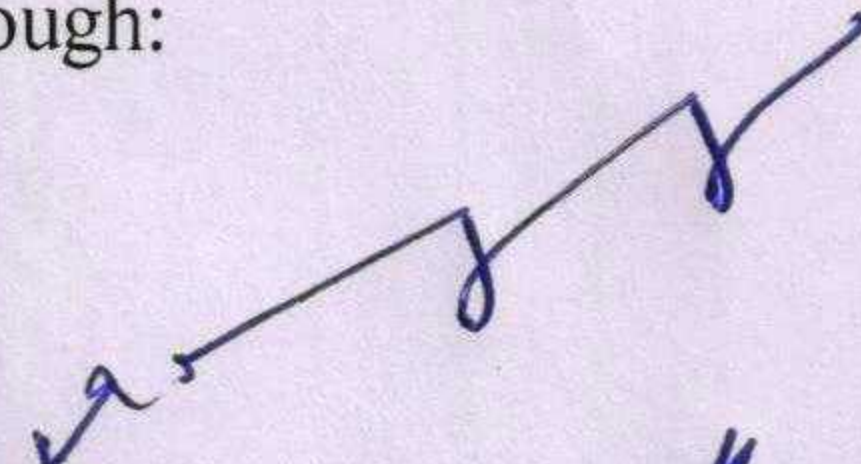
Dr. R. Ananthasayan, SO/F
IC No: 6504.

Regards,

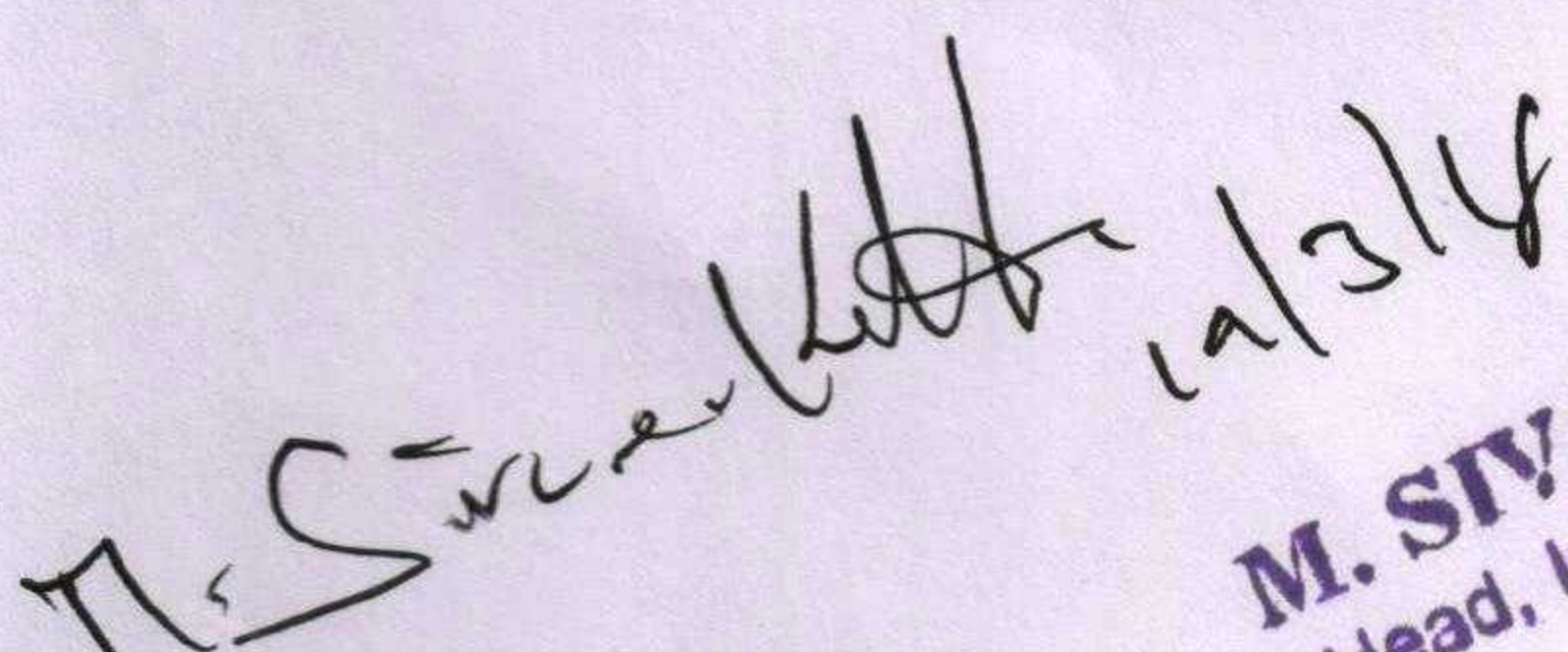
19/3/19

M. SIVARAMAKRISHNA
Head, Innovative Sensors Section
SISD/EIG
Indira Gandhi Centre for Atomic Research
Department of Atomic Energy
Kalpakkam - 603 102, Tamil Nadu



B.S. Abdur Rahman

Crescent

Institute of Science & Technology

Deemed to be University u/s 3 of the UGC Act, 1956

School of Physical and Chemical Sciences

Department of Physics

The following second year B. Sc., Physics students from Meenakshi College of women (Autonomous), Kodambakkam have carried out their summer internship programme at Department of Physics, B. S. Abdur Rahman Crescent Institute of Science and Technology from 13-05-2019 to 24-05-2019.

Sl. No.	Name of the Student	Signature of Student
1.	M.NANDHINI	M. Nandhini
2.	G.AKALYA	G. Akalya
3.	R.ANUNITHA	R. Anunitha
4.	A.JOTHIKA	A. Jothika
5.	R.SABITHA	R. Sabitha
6.	S.MADHUMITHA	S. Madhumitha
7.	R.AARTHI	R. Aarthi

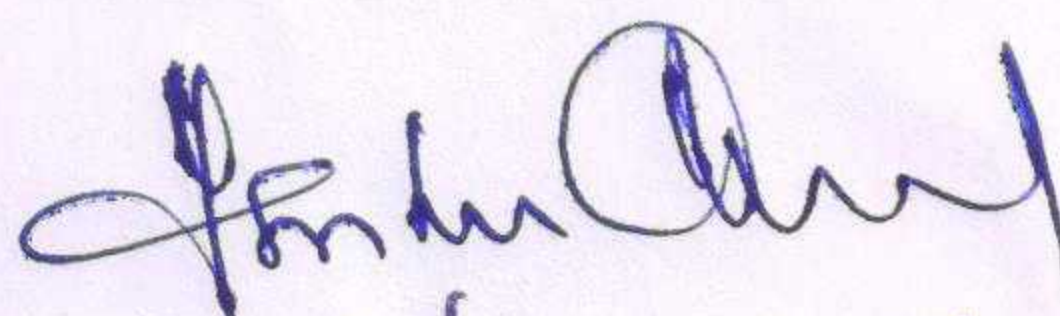
HOD / PHYSICS

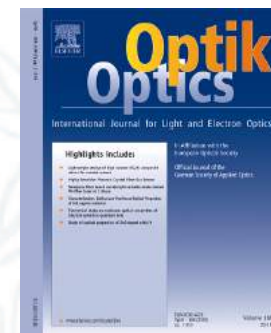

Optik

Certificate of Reviewing

Awarded since March 2019 (1 review)
presented to

BASHEER AHAMED M

in recognition of the review contributed to the journal

The Editors of Optik

