



B.S.ABDUR RAHMAN

**CRESCENT UNIVERSITY**

B.S.Abdur Rahman Crescent Institute of Science & Technology  
(Estd. u/s 3 of the UGC Act, 1956)

**SCHOOL OF PHYSICAL AND CHEMICAL SCIENCES**

**DEPARTMENT OF PHYSICS**

**ENGINEERING PHYSICS  
LAB MANUAL**

*(As per 2017 Academic Regulation)*

***Common to all branches of B. Tech. First Year***

# CONTENTS

## LAB INSTRUCTIONS

## MEASURING INSTRUMENTS

- I. Screw Gauge
- II. Vernier Calipers
- III. Travelling Microscope
- IV. Spectrometer

## LIST OF EXPERIMENTS

1. Determination of Velocity of Ultrasonic waves in a given liquid using Ultrasonic Interferometer.
2. Determination of thickness of a thin wire using Air Wedge method.
3. Determination of wavelength of light using spectrometer diffraction grating.
4. Determination of angle of divergence of a laser beam using He-Ne laser.
5. Determination of particle size of lycopodium powder using semiconductor laser.
6. Determination of wavelength of laser light using semiconductor laser diffraction.
7. Determination of Acceptance angle and Numerical Aperture using fiber optic cable.
8. Determination of thermal conductivity of a bad conductor by Lee's disc method.
9. Determination of wavelength of ultrasonic waves using Kundt's tube method.
10. Determination of thermal conductivity of a good conductor by Forbe's method.
11. Determination of solar cell characteristics.

## GENERAL LAB INSTRUCTIONS

1. The students should attend the lab neatly with proper prescribed uniform.
2. The record notebook should be covered with the laminated brown sheet neatly and they should bring it to every lab class.
3. Before any cycle of experiments, a class is spent on demonstrating those experiments. The students should not miss that class for any reason and they have to be very attentive in that class.
4. They should read the procedure thoroughly for the lab experiment from the manual and come well prepared.
5. They should bring the required things like scientific calculator, eraser, pencil, pen etc to every lab class. Borrowing things is not allowed.
6. They should not go to others table leaving their place without taking permission from the staff. They should maintain silence in the class.
7. They should do the experiment systematically and write their observations neatly in the record note book with pen. After writing a few readings in the beginning, they should show the record note book to their faculty member and get attestation for the readings from the faculty. After completing the experiment, they should do the calculations neatly.
8. They should complete the calculation in the lab class itself and get the signature from the staff. In case if they are not able to complete, they should get attestation from the staff in the record note book for the readings taken and get the result corrected the next day itself, by submitting the notebook in the lab. They have to collect their note book from the staff after a day.
9. They should not miss any lab class. This will be viewed very seriously. If they miss the lab class due to unavoidable reason, they will be allowed for the next lab provided they submit a letter signed by the parent or Deputy warden (hosteller) stating the reason. It is the responsibility of the students to complete

the missed experiments as soon as possible after getting permission from the faculty incharge.

10. In every lab class, the students have to sign in a register while receiving the apparatus from the lab assistants. After completing the experiment, they should hand over the apparatus and sign in the register again, failing which it would be assumed that they haven't returned the apparatus and the cost of the apparatus will be collected from them. So it is the responsibility of the students to return the apparatus to the lab assistants as soon as they complete the lab work.

## INSTRUCTIONS FOR WRITING IN RECORD NOTE

- Before coming to the lab, the students should write the experiment number, date, aim, formula, least count calculation, ray diagram or circuit diagram, tabular column neatly in the record note book. The record note book will be checked in the beginning of the lab class.

## RECORD NOTE LAYOUT

1. Title of the Experiment : (Right hand side)
2. Date of Commencement : (Right hand side)
3. Date of Completion and reporting : (Right hand side)
4. Objectives of the experiment : (Right hand side)
5. Aim of the experiment : (Right hand side)
6. Apparatus required : (Right hand side)
7. Formula in detail : (Right hand side)
8. Procedure of the experiment : (Right hand side)
9. Experimental setup/Circuit diagram : (Left hand side)
10. Tabular column : (Left hand side)
11. Calculation : (Left hand side)
12. Result : (Right hand side)
13. Learning outcome achieved : (Right hand side)

## I. SCREW GAUGE

### Aim

To determine the thickness of a glass plate.

### Apparatus required

Screw gauge and glass plate

### Description

It is based upon the principle of a screw. It consists of a U-shaped metal frame. One end of which carries a fixed stud A whereas the other end B is attached to a cylindrical tube as shown in Fig. 1. A scale graduated in millimetres is marked on the cylindrical tube along its length. It is called Pitch scale.

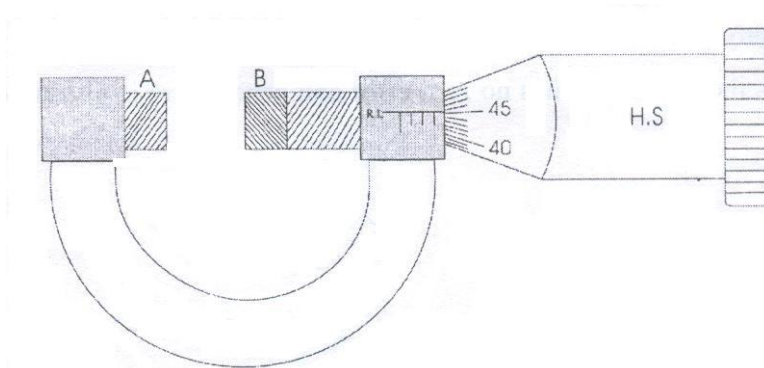

**Fig.1 Screw Gauge**

The screw carries a head H which has a beveled edge. The edge is divided into 100 equal divisions. It is called the Head scale H.S. When the head is rotated, the head scale moves on the pitch scale.

### Procedure:

#### 1. To find the least count (LC) of the screw gauge

Least count of a screw gauge is the distance through which the screw tip moves when the screw is rotated through one division on the head scale.

$$\text{Pitch} = \frac{\text{Distance moved by the head scale on the pitch scale}}{\text{Number of rotations given to the head scale}}$$

$$\text{Least count (LC)} = \frac{\text{Pitch}}{\text{Total number of divisions on head scale}}$$

To find the pitch, the head or the screw is given say 5 rotations and the distance moved by the head scale on the pitch scale is noted. Then by using the above formula, the least count of the screw gauge is calculated.

$$\text{Pitch} = 5 \text{ mm} / 5 = 1 \text{ mm}$$

$$\text{Least Count} = 1 \text{ mm} / 100 = 0.01 \text{ mm}$$

The screw head is rotated until the two plane faces A and B are just in contact.

## 2. To find the zero correction (ZC)

### i) Nil error

If the zero of the head scale coincides with the zero of the pitch scale and also lies on the base line (B.L), the instrument has no zero error and hence there is no zero correction (See Fig.

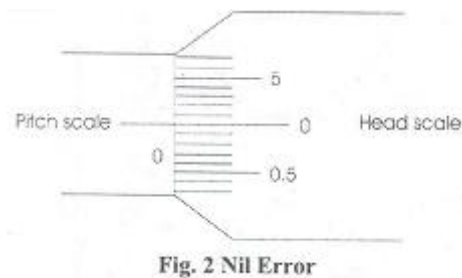

### ii) Positive zero error

If the zero of the head scale lies below the base line (B.L) of the pitch scale then the zero error is positive and zero correction is negative. The division on the head scale, which coincides with the base line of pitch scale, is noted. The division multiplied by the least count gives the value of the positive zero error. This error is to be subtracted from the observed reading i.e. the zero correction is negative (See Fig.3).

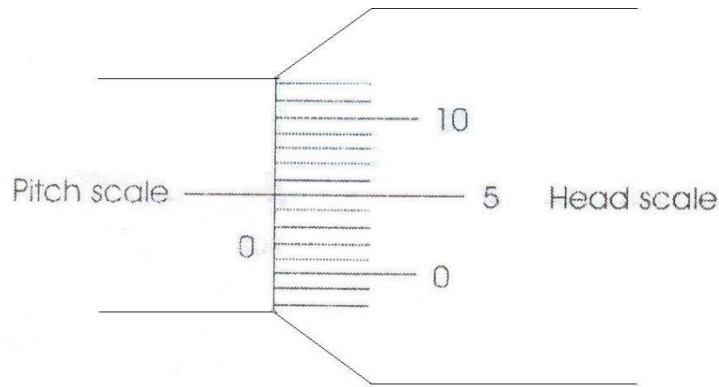

**Fig. 3. Positive Zero Error**

### Example

If 5<sup>th</sup> division of the head scale coincides with the base line of the pitch scale then Zero error = +5 divisions

$$\text{Zero correction} = (\text{Z.E} \times \text{LC}) = -(5 \times 0.01) = -0.05 \text{ mm.}$$

### iii) Negative zero error

If the zero of head scale lies above the base line (B.L) of the pitch scale, then the zero error is negative and zero correction is positive. The division on the head scale which coincides on the base line of pitch scale is noted. This value is subtracted from the total head scale divisions. This division multiplied by the least count gives the value of the negative error. This error is to be added to the observed reading i.e. zero correction is positive (See Fig. 4).

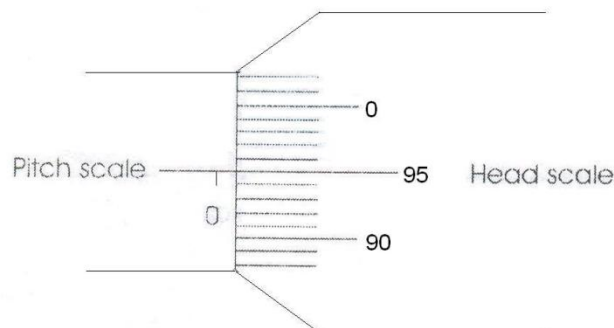

**Fig. 4 Negative Zero Error**

### Example

If the 95<sup>th</sup> division of the head scale coincides with the base line of the pitch scale then,

$$\text{Zero error} = -5 \text{ divisions}$$

$$\text{Zero correction} = +0.05 \text{ mm}$$



### 3. To find the thickness of the glass plate

The glass plate is gently gripped between the faces A and B. The pitch scale reading and the head scale coincidence are noted. The readings are tabulated.

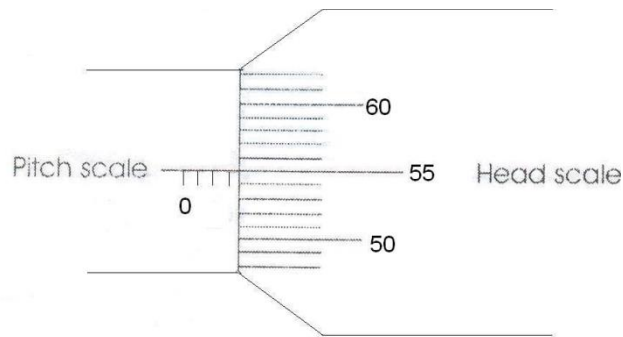

**Fig. 5 Screw Gauge Readings**

#### Pitch Scale Reading (P.S.R)

Number of pitch scale division just in front of the head scale fully completed is noted (see Fig. 5). It is measured in millimeter.

#### Head Scale Coincidence (H.S.C)

Coincidence of head scale division on the base line of the pitch scale is also noted.

#### Example:

**Screw gauge readings:** (see Fig. 5)

LC = 0:01 mm      Zero error = -3 divisions      Zero correction (Z.C.) = +0.03 mm

S.No.	P.S.R mm	H.S.C div	H.S.R = (H.S. C x LC) mm	Total Reading = P.S.R+ H.S.R mm	Corrected Reading = T.R. ± Z.C. mm
1	4	56	0.56	4.56	4.59
2					
3					
4					

Mean thickness of the glass plate =

## II. VERNIER CALIPERS

### Aim

To measure the dimensions of the given object.

### Apparatus

Vernier Calipers and Wooden block

### Description

The vernier calipers consist of a long rigid rectangular steel strip called the main scale (M.S) with a jaw (A) fixed at one end at right angles to its length as shown in Fig.1. The main scale is graduated both in centimeters and inches. The second jaw (B) carrying a vernier scale and capable of moving along the main scale can be fixed to any position by means of a screw cap S. The vernier scale is divided into 10 divisions, which is equivalent to 9 main scale divisions (M.S.D). So the value of 1 vernier scale division is equal to  $\frac{9}{10}$  M.S.D. The value of 1 M.S.D. is 1 mm

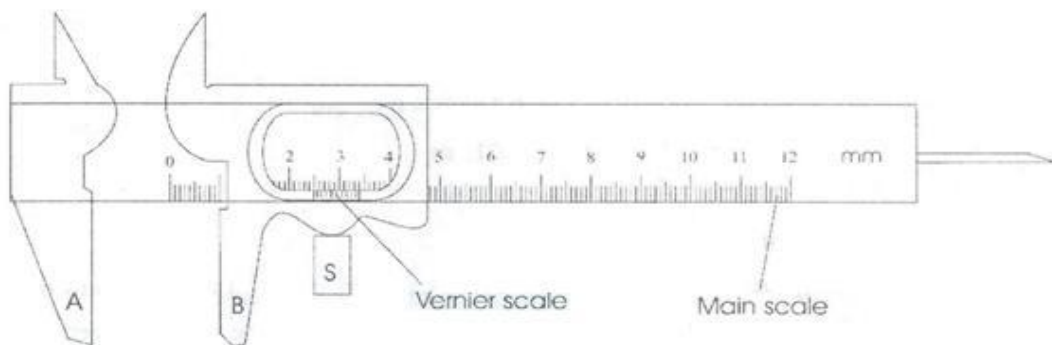
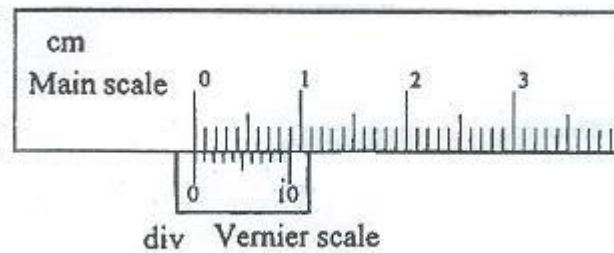

**Fig.1. Vernier Calipers**

### Procedure:

#### 1. To find the Least Count (LC) of the vernier calipers (see Fig. 2)

It is the smallest length that can be measured accurately by the vernier calipers and is measured as the difference between one main scale division and one vernier scale division.



**Fig. 2 Vernier scale and main scale**

$$\text{Least Count (LC)} = 1 \text{ M.S.D} - 1 \text{ V.S.D}$$

Value of 1 M.S.D = 1 mm

No of divisions on the vernier scale = 10 divisions.

$$10 \text{ V.S.D} = 9 \text{ M.S.D}$$

$$1 \text{ V.S.D} = 9/10 \text{ M.S.D} = 9/10 \times 1 \text{ mm} = 9/10 \text{ mm}$$

$$\text{L.C.} = 1 \text{ M.S.D} - 1 \text{ V.S.D}$$

$$= 1 \text{ mm} - 9/10 \text{ mm}$$

$$= 0.1 \text{ mm} = 0.01 \text{ cm}$$

$$\text{L.C.} = 0.01 \text{ cm}$$

## 2. To find the Zero Correction (ZC)

Before taking the readings with the vernier calipers, we must note the zero error of the vernier calipers. When the two jaws of the vernier calipers are pressed together, if the zero of the vernier scale coincides with the zero of the main scale the instrument has no error, otherwise there is a zero error. The zero error is positive if the vernier zero is after the main scale zero. The zero error is negative when the vernier zero is before the main scale zero. Ordinarily, the zero error is negligible in the case of vernier calipers and so zero error can be considered to be nil.

## 3. To find the length of the given object

The given object is firmly gripped between the jaws, taking care not to press it too hard. The main scale reading and the vernier coincidence are noted. The main scale reading is the reading on the main scale that is just before the vernier

zero. The vernier scale coincidence is found by noting the vernier division that coincides with any one of the main scale. Then the vernier scale reading is found by multiplying the vernier coincidence with the least count. The observations are repeated for various positions of the object.

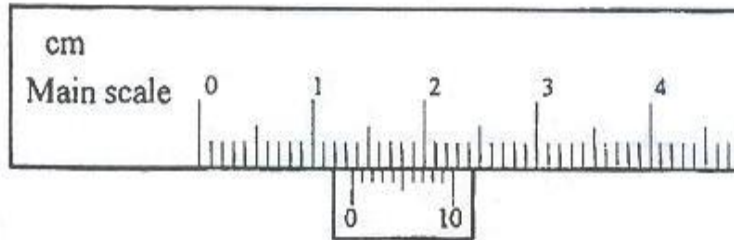

**Fig. 3 Vernier Caliper readings**

**Example:**

**Vernier Calipers readings: (See Fig. 3)**

LC = 0.01cm

S. No.	M.S.R cm	V.S.C.- div	V.S.R = (V.S.0 x LC) cm	Total Reading = M.S.R+ V.S.R cm	Corrected Reading = T.R. ± Z.C. cm
1	1.3	6	0.06	1.36	1.36
2					
3					
4					

Mean length of the given object =

### III. THE TRAVELLING MICROSCOPE

#### Aim:

To learn the parts of a Travelling Microscope and to read a reading.

#### Apparatus:

Reading lens and capillary tube

#### Description:

It is a compound microscope attached to a graduated vertical pillar, which is mounted on rigid platform (Fig. 1). The platform is provided with three levelling screws. The microscope can be set with its axis either in the vertical or the horizontal position. The microscope can be moved in the vertical or horizontal direction by means of a screw arrangement attached to it. The distance through which the microscope is moved is read on the scale. There are two scales one for horizontal movement and the other for the vertical movement. Each scale has a main scale ( $M_1$ ,  $M_2$ ) and a vernier scale ( $V_1$ ,  $V_2$ ). The vernier moves with the microscope. As in the spectrometer, there is a set of main screw and fine adjustment screw, for the horizontal and the vertical movements. One set is fixed to the pillar for vertical movement and the other set is fixed to the platform for horizontal movement. The eyepiece of the microscope is provided with cross-wires. The image of an object is focussed by the microscope using a side screw (focusing screw) attached to the microscope.

#### Procedure:

##### 1.To find the Least Count (LC) of the travelling microscope

The main scale is graduated in mm. There are 50 V.S.D equivalent to 49 M.S.D.

The value of one M.S.D. is  $0.5\text{mm}=0.05\text{cm}$

$$\begin{aligned}
 \text{LC} &= 1 \text{ M.S.D} - 1 \text{ V.S.D.} \\
 1 \text{ M.S.D} &= 0.05 \text{ cm} \\
 50 \text{ V.S.D} &= 49 \text{ M.S.D} \\
 1 \text{ V.S.D} &= \frac{49}{50} \times 0.05 = 0.049 \text{ cm} \\
 \text{LC} &= 0.05 - 0.049 \text{ cm} \\
 \text{LC} &= \mathbf{0.001\text{cm}}
 \end{aligned}$$



**Fig. 1 Travelling Microscope**

## 2. To read a reading

When the microscope is clamped by the main screw or fine adjustment screw at any position, the reading is taken in the vertical scale or in the horizontal scale according to the requirement. M.S.R and V.S.R are taken as in the vernier calipers. For example see Fig. 2. And write the M.S.R and V.S.R.

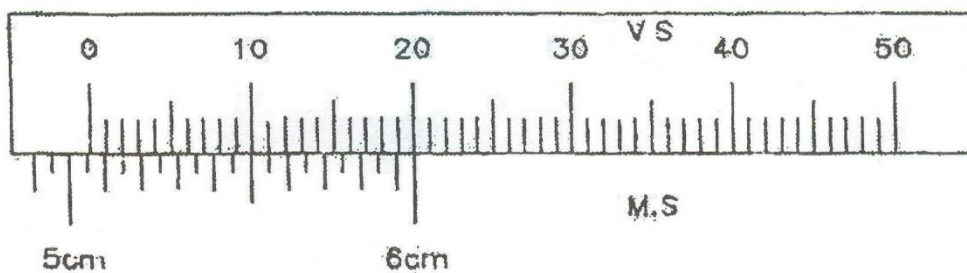

**Fig. 2 Vernier and Main scale**

### Note:

In the Vernier calipers, travelling microscope and the spectrometer, the MS zero may coincide with the VS zero. In such cases, the MSD, which coincides with the VS zero is the MSR reading.

**Example:****Travelling microscope readings:**

LC = 0.001cm

S. No.	M.S.R cm	V.S.C div	V.S.R = (V.S.C x LC) Cm	T.R = M.S.R + V.S.R cm
1	5.05	20	0.02	5.07
2				
3				
4				
5				

**Result:**

The parts and functions of the travelling microscope are studied and a few readings are taken.

## IV. THE SPECTROMETER

### Aim:

To learn the parts of a spectrometer and to read a reading.

### Apparatus required:

Spectrometer, reading lens and spirit level

### Description:

i. It has the following three main parts ( see Fig.1) .

1. The collimator    2. The telescope    3. The prism table

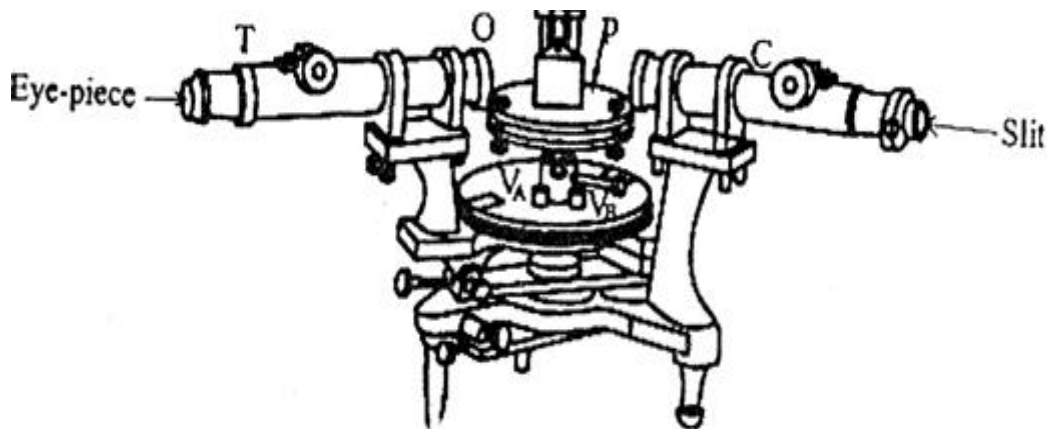

**Fig. 1. Spectrometer**

**1. The collimator:** Its purpose is to produce a parallel beam of light. It consists of a lens and slit. The slit faces the source of light. The distance between the slit and the lens can be adjusted by a screw fixed to the collimator tube C to obtain parallel beam of rays. The slit consists of two sharp edges. One of the edges is fixed while the other can be moved parallel to it by working the screw provided at its side. The collimator cannot be rotated.

**2. The telescope:** The telescope T consists of an objective O at one and an eyepiece fixed with the cross wires on the other end. The telescope is fixed to the circular scale graduated in degrees. The circular scale is in between the collimator and the telescope. The telescope can be turned with the scale about a vertical axis passing through the center of the spectrometer. The eyepiece of the telescope is provided with cross — wires. The telescope can be fixed in any position by a main screw. Fine adjustment can be made by a fine adjustment screw which is



tangential to the main screw. The focusing of the telescope is done by a screw to the side of the telescope.

3. **The prism table:** This consists of a upper plate and a lower plate separated by three springs. Three screws pass through these springs. There are lines engraved in the upper plate so as to mount the prism in proper position. The prism table P can be mounted in any position by means of a screw at its bottom. The prism table can be rotated about the same vertical axis as the telescope.

## ii. The initial adjustments:

1. **Telescope adjustment:** The telescope is turned towards a distant object and its focusing screw is adjusted till the image of the object is clearly seen. In this position, the telescope is capable of receiving parallel rays.
2. **Collimator adjustment:** The slit is illuminated with sodium vapour lamp or Hg vapour lamp. The telescope is turned so that the telescope and the collimator are in a line. In this position one can see the image of the slit through the telescope. The clear image of the slit is obtained by adjusting the collimator screw. The slit must be adjusted to be narrow and vertical.
3. **Levelling of the prism table:** This is done with a spirit level. The spirit level is kept on the prism table and the three leveling screws of the prism table are adjusted till the air bubble comes to the centre.

## Procedure:

### 1. To find the least count of the spectrometer:

The main scale is a circular scale graduated in degrees. The value of one MSD is half degree. Each vernier scale consists of 30 divisions (Fig. 2).

29 MSD are equal to 30 VSD (Fig.2).

$$\begin{aligned}
 \text{LC} &= 1 \text{ MSD} - 1 \text{ VSD} \\
 1 \text{ MSD} &= 0.5^\circ = 30' \quad (1^\circ = 60') \\
 30 \text{ VSD} &= 29 \text{ MSD} \\
 1 \text{ VSD} &= \frac{29}{30} \text{ MSD} \\
 &= \left(\frac{29}{30}\right) \times 30' \\
 &= 29'
 \end{aligned}$$

$$1 \text{ LC} = 30' - 29'$$

$$\text{LC} = 1'$$

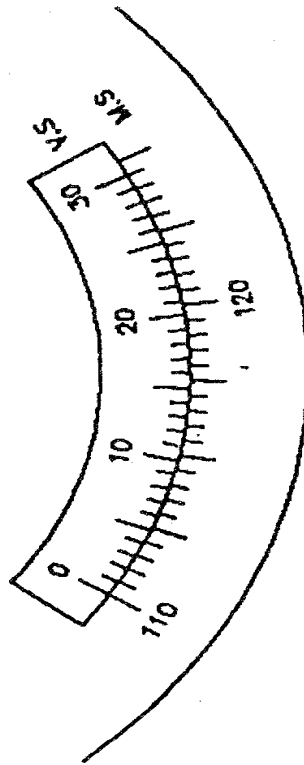
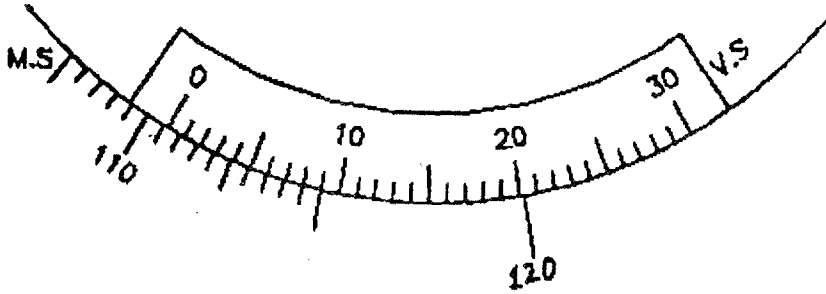

**Fig. 2 Circular scale of the spectrometer**

## 2. To read a reading

Main scale reading (MSR) and vernier scale reading (VSR) are noted as explained in the vernier calipers when the telescope and the disc (prism table) are fixed at the required position by the main or fine adjustment screw.

The two vernier scales VA and VB are fixed to the disc, which can be rotated about the same vertical axis. A main screw and a fine adjustment screw as in the telescope control the movement of the vernier scales.



**Fig. 3 Spectrometer readings**

**Example:**

**Spectrometer readings: (see fig. 3)**

LC = 1'

S. No.	M.S.R	V.S.C div	V.S.R = V.S.C x L.C	T.R = M.S.R + V.S.R
1	110.5° = 110° 30'	9	9'	110°39'

# 1. DETERMINATION OF VELOCITY OF ULTRASONIC WAVES IN A LIQUID USING ULTRASONIC INTERFEROMETER

## Objectives

- To make students to understand the principle of interferometer
- To make students to understand the principle of acoustical grating
- To determine the velocity of the ultrasonic waves in the liquid using acoustical grating
- To determine the compressibility of the given liquid from the velocity of the ultrasonic waves

## Aim

To determine the velocity of ultrasonic waves in a given liquid and also to determine the compressibility of the liquid

## Apparatus required

Ultrasonic interferometer, measuring cell, frequency generator, given liquid, etc.

## Formula

**1. Velocity of ultrasonic waves in the given liquid,  $v = \lambda f$  m/s**

**2. Compressibility of the given liquid,  $K = \frac{1}{v^2 \rho} m^2/N$**

where  $\lambda = 2d/n$  is the wavelength of the Ultrasonic wave in m

f is the Frequency of Ultrasonic waves in Hz

d is the distance moved by the micrometer screw in m

n is the number of oscillations  $\rho$  is the density of the given liquid in  $kgm^{-3}$

## Theory

An Ultrasonic Interferometer is a simple and direct device to determine the velocity of Ultrasonic waves in liquid with a high degree of accuracy. Here the high frequency generator generates variable frequency, which excites the Quartz crystal placed at the bottom of the measuring cell (Fig. 1). The excited Quartz crystal generates Ultrasonic waves in the experimental liquid. The liquid will

now serve as an acoustical grating element. Hence when Ultrasonic waves pass through the rulings of grating, successive maxima and minima occur, satisfying the condition for diffraction.

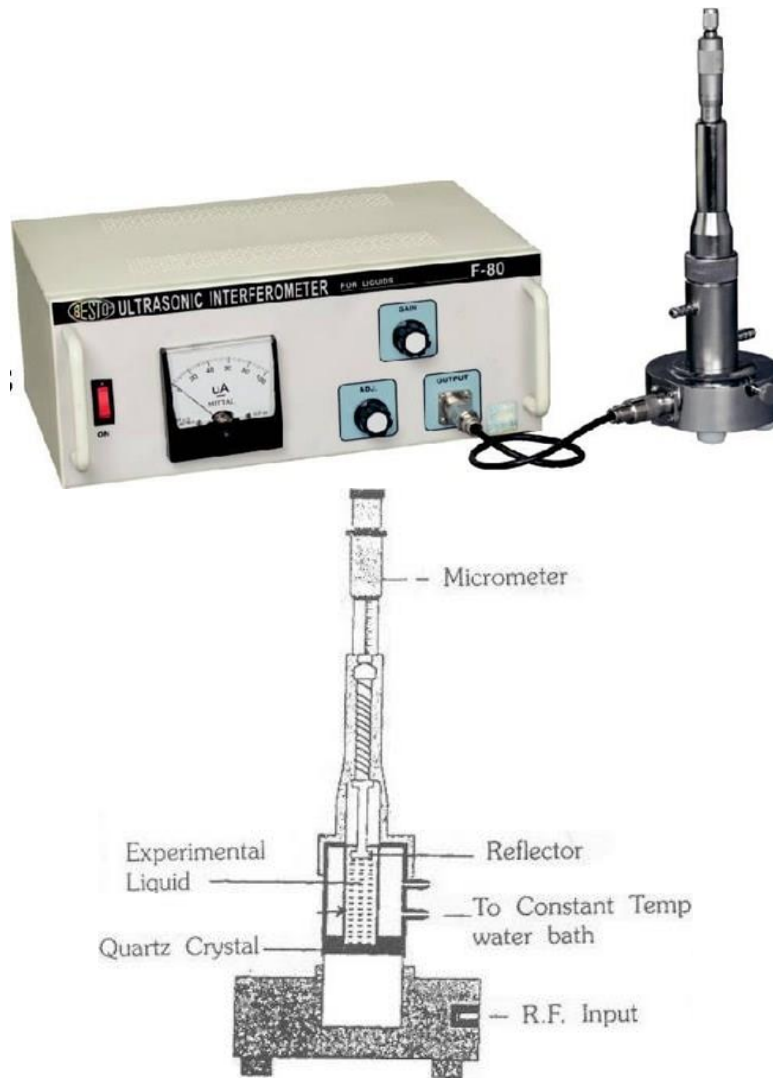

Figure 1

**Fig. 1 Ultrasonic interferometer**

**Initial adjustments:** In high frequency generator two knobs are provided for initial adjustments. One is marked with 'Adj (set)' and the other with 'Gain' (Sensitivity). With knob marked 'Adj' the position of the needle on the ammeter is adjusted and with the knob marked 'Gain', the sensitivity of the instrument can be increased for greater deflection, if desired.

## Procedure

The measuring cell is connected to the output terminal of the high frequency generator through a shielded cable. The cell is filled with the experimental liquid before switching ON the generator. Now, when the frequency generator is switched ON, the Ultrasonic waves move normal from the Quartz crystal till they are reflected back by the movable reflector plate. Hence, standing waves are formed in the liquid in between the reflector and the quartz crystal. The distance between the reflector and crystal is varied using the micrometer screw such that the anode current of the generator increases to a maximum and then decreases to a minimum and again increases to a maximum. The distance of separation between successive maximum or successive minimum in the anode current is equal to half the wavelength of the Ultrasonic waves in the liquid. (see Fig.2). Therefore, by noting the initial and final position of the micrometer screw for one complete oscillation (maxima—minima—maxima) the distance moved by the reflector can be determined

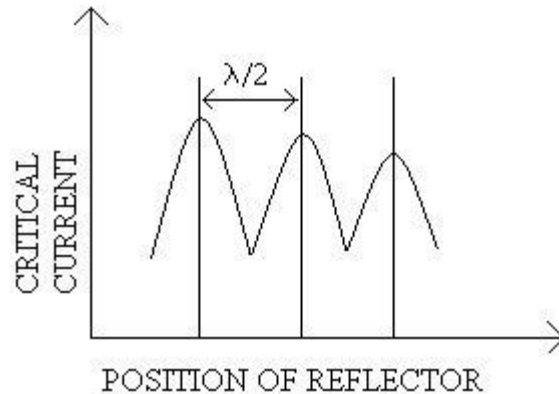

To minimize the error, the distance ( $d$ ) moved by the micrometer screw is noted for ' $n$ ' number of oscillations (successive maxima), by noting the initial and final reading in the micrometer screw and is tabulated. From the total distance ( $d$ ) moved by the micrometer screw and the number of oscillations ( $n$ ), the wavelength of ultrasonic waves can be determined using the formula  $\lambda = 2d/n$ . From the value of  $k$  and by noting the frequency of the generator ( $f$ ), the velocity of the Ultrasonic waves and compressibility of the given liquid can be calculated using the given formula.

## (i) To find the velocity of Ultrasonic waves in the liquid

Type of liquid =

Frequency of the Generator (f) = .....Hz

LC = 0.01 mm

S. No.	No. of oscillations (n)	Reading for 'n' oscillations								d=R <sub>1</sub> -R <sub>2</sub> X 10 <sup>-3</sup> in m	λ= 2d/n X 10 <sup>-3</sup> in m	Velocity v= f λ in ms <sup>-1</sup>
		Initial reading ( R <sub>1</sub> )				Final Reading( R <sub>2</sub> )						
		PSR X 10 <sup>-3</sup> m	HSC div	HSR X10 <sup>-3</sup> m	TR X10 <sup>-3</sup> m	PSR X 10 <sup>-3</sup> m	HSC div	HSR X 10 <sup>-3</sup> m	TR X10 <sup>-3</sup> m			

Mean =





### Calculation

- (i) Wavelength of the Ultrasonic waves =  
 Frequency of Ultrasonic waves =  
 The velocity of Ultrasonic waves in the given liquid,  $v$  =
- (ii) Density of the given liquid ( $\rho$ ) =  
 The Compressibility of the given liquid,  $K$  =

Velocity of Ultrasonic waves in the given liquid,  $v = \lambda f$

Compressibility of the given liquid,  $K = 1/v^2 \rho$

### Result

1. Velocity of ultrasonic waves in the given liquid,  $v$  =
2. Compressibility of the given liquid,  $K$  =

### Outcome

At the end of this experiment, the students would be able

- To know the principle underlying the formation of acoustical grating
- To know how to determine the velocity of ultrasonic waves in liquid
- To know how to determine the compressibility of the liquid from the velocity of the ultrasonic waves

## 2. DETERMINATION OF THICKNESS OF A THIN WIRE USING AIR WEDGE METHOD

### Objectives

- To familiarize with the working knowledge of the principle of interference
- To determine the dimensions of very small specimen using the principle of Air wedge
- To observe the variation of fringe width for different positions of specimen
- To determine the wavelength of monochromatic source with knowledge of dimension of specimen

### Aim

To determine the thickness of a thin wire using air wedge method

### Apparatus required

Two optically plane rectangular glass plates, thin wire, travelling microscope, reading lens, sodium vapour lamp, condensing lens with stand, wooden box with glass plate inclined at 45°.

### Formula

**1. The thickness of the wire,  $t = \frac{l\lambda}{2\beta} m$**

**2. Wedge angle,  $\theta = \frac{t}{l} \text{ radians}$**

Where  $\lambda$  is the wavelength of sodium light in m

$l$  is the distance of the wire from the edge of contact (l) in m

$\beta$  is the width of one fringe in m

### Procedure

The experimental arrangement and ray diagram are shown in Fig. 1. Two optically plane glass plates are placed one over other and tied together by means of a rubber band at one end. A thin wire is inserted between the plates at the other end. Now

a wedge shaped air film is formed between the two glass plates. The slide system is kept on the platform of a travelling microscope. The light from a sodium vapour lamp is rendered parallel with a condensing lens and is made to incident on a plane glass sheet held over the wedge at an angle of  $45^\circ$  with the vertical. The light falling on the sheet is partially reflected which is in turn incident normally on the air wedge. Adjusting the arrangement properly, the microscope field of view is made bright to the maximum extent. The microscope is moved vertically up and down till parallel fringes are visible which are located on the surface of the air film (Fig.2). By moving the microscope in a horizontal direction, the cross-wires of the microscope are set on one of the dark ( $n^{\text{th}}$ ) fringes in the pattern. Its position is noted down in the horizontal scale.

The microscope is moved further using the tangential screw along the length of the air film counting the number of dark fringes. After counting 2 dark fringes, the cross wire is coincided with the  $(n+2)^{\text{nd}}$  fringe and its position is noted. The measurements are repeated similarly for every alternate dark fringe and are noted. The width of 10 dark fringes is calculated from the table and the mean width of 10 fringes is averaged out. From this, the fringe width  $\beta$  is calculated. The length of the air film is measured as the distance between the line of contact and the inner edge of the wire. The measurement can be done using the travelling microscope or with the calibrated scale.

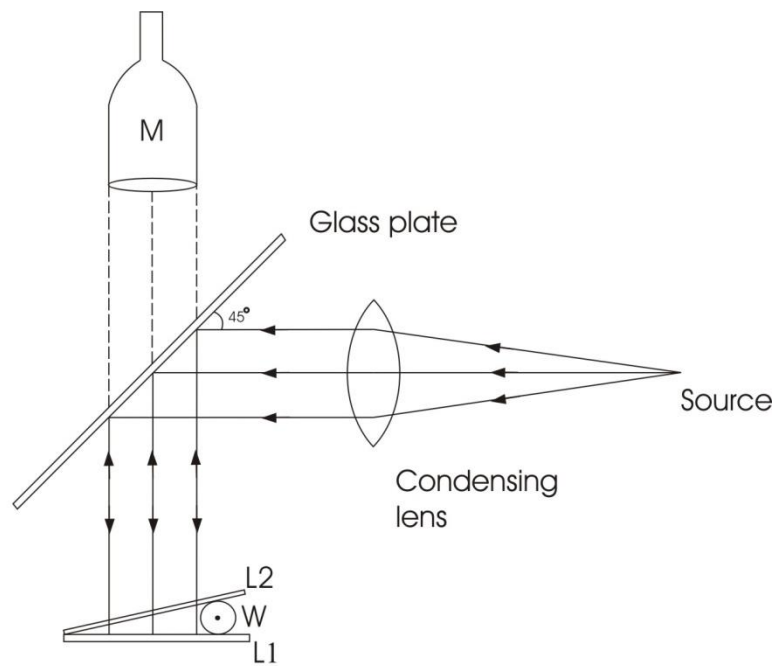

- S - Source (Sodium vapour light)  
 L - Condensing lens (convex lens)  
 G - Glass plate inclined at  $45^\circ$   
 L1, L2 - Transparent plane glass plates

**Fig. 1 Experimental arrangement**

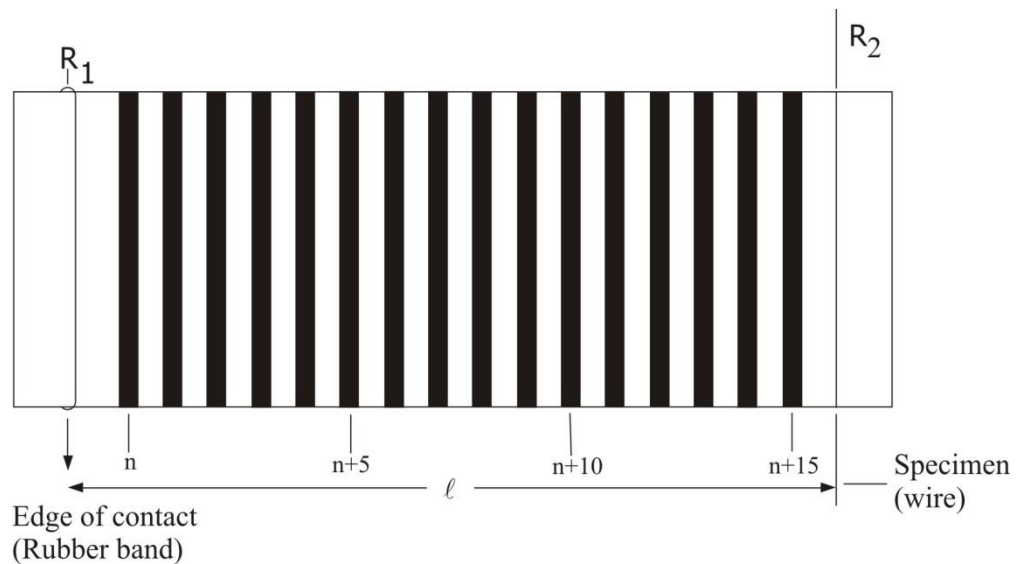

**Fig. 2 Fringe pattern**

To find the fringe width ( $\beta$ )

Least count = 0.001cm

Order of fringes	Microscope reading				Order of fringes	Microscope reading				Width of 25 fringes cm
	M.S.R cm	V.S.C div	V.S.R cm	T.R cm		M.S.R cm	V.S.C div	V.S.R cm	T.R cm	
n					n+25					
n+5					n+30					
n+10					n+35					
n+15					n+40					
n+20					n+45					

Mean width of 25 fringes =

### Calculations

Wavelength of sodium light ( $\lambda$ ) = m

Distance of the wire from the edge of contact ( $l$ ) = m

Mean width of 25 fringes = m

Width of one fringe ( $\beta$ ) = m

$$\text{The thickness of the wire, } t = \frac{l\lambda}{2\beta}$$

$$\text{Wedge angle, } \theta = \frac{t}{l}$$

### Result

1. The thickness of the wire,  $t =$
2. Wedge angle,  $\theta =$

**Outcome**

At the end of this experiment, the students would be able

- To understand the principle of interference
- To determine the dimensions of a thin specimen such as wire, thin foil, thin paper
- To determine the wavelength of monochromatic source applying the principle of Air wedge
- To understand applications of interference

### 3. DETERMINATION OF WAVELENGTH OF LIGHT USING SPECTROMETER DIFFRACTION GRATING

#### Objectives

- To understand the types of diffraction
- To familiarize with the principle of diffraction in plane transmission grating
- To know the procedure for standardization of the grating
- To determine the wavelengths of prominent spectral lines of mercury spectrum

#### Aim

To determine the wavelength of the prominent lines in the mercury spectrum using spectrometer diffraction grating

#### Apparatus required

Spectrometer, plane transmission grating, sodium vapour lamp, mercury vapour lamp, reading lens

#### Formula

*Wavelength of the prominent lines in the mercury spectrum,  $\lambda = \frac{\sin\theta}{Nn} m$*

where  $\theta$  is the angle of diffraction in degrees

n is the order of diffraction (spectrum)

N is the number of lines per metre in the grating

#### Procedure

##### Initial adjustments

- Telescope adjustment:** The telescope is turned towards a distant object and its focusing screw is adjusted till the image of the object is clearly seen. In this position, the telescope is capable of receiving parallel rays.

- b. Collimator adjustment:** The slit is illuminated with sodium vapour lamp or Hg vapour lamp. The telescope is turned so that the telescope and the collimator are in a line. In this position one can see the image of the slit through the telescope. The clear image of the slit is obtained by adjusting the collimator screw. The slit must be adjusted to be narrow and vertical.
- c. Levelling of the prism table :** This is done with a spirit level. The spirit level is kept on the prism table and the three levelling screws of the prism table are adjusted till the air bubble comes to the centre.

#### **Adjustment of the grating for normal incidence (Fig.1)**

1. After making the initial adjustments, the plane transmission grating is mounted on the grating table.
2. The telescope is released and placed in front of the collimator. The direct reading is taken after making the vertical cross-wire to coincide with the fixed edge of the image of the slit which is illuminated by a source of light.
3. The telescope is then rotated by an angle  $90^{\circ}$  (either left or right) and fixed.
4. The grating table is rotated until on seeing through the telescope the reflected image of the slit coincides with the vertical cross-wire. This is possible only when a light emerging out from the collimator is incident at an angle  $45^{\circ}$  to the normal to the grating.

The vernier table is now released and rotated by an angle  $45^{\circ}$  towards the collimator. Now light coming out from the collimator will be incident normally on the grating (Fig. 1).



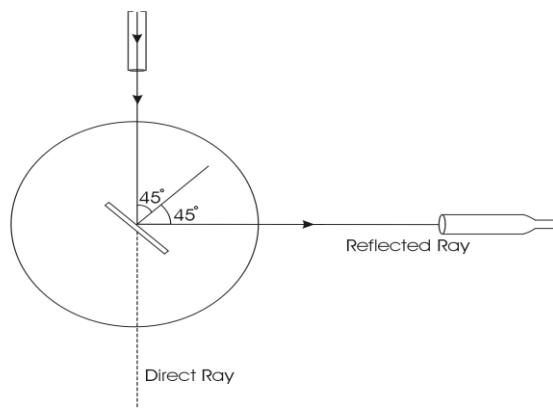

Normal Incidence position

### To find the wavelengths of the spectral lines of the mercury spectrum

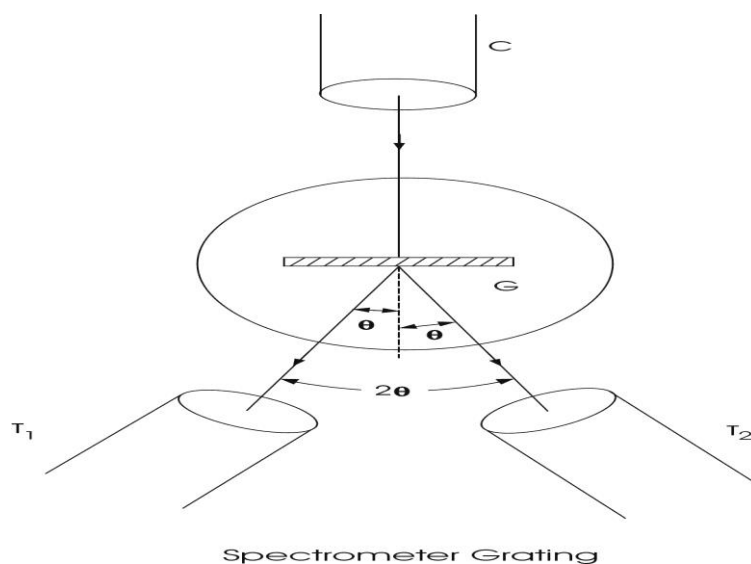

The slit is now illuminated by white light from mercury vapour lamp. (Fig. 2)

The central direct image will be an undispersed image. The telescope is moved to either side of the direct image, the diffraction pattern of the spectrum of the first order and second order are seen.

The readings are taken by coinciding the prominent lines namely violet, green, yellow and red with the vertical cross wire. The readings are tabulated and from this, the angles of diffraction for different colours are determined. The wavelengths for different lines are calculated by using the given formula. The number of lines per metre in grating is assumed.



### Calculation

Order of diffraction (n)	=	
Number of lines per meter in the grating (N)	=	-----lines/m
Angle of diffraction in degrees for violet line ( $\theta$ )	=	
Wavelength of the violet line ( $\lambda_V$ )	=	$\frac{\sin \theta}{Nn}$ m =
Angle of diffraction in degrees for blue line ( $\theta$ )	=	
Wavelength of the blue line ( $\lambda_B$ )	=	$\frac{\sin \theta}{Nn}$ m =
Angle of diffraction in degrees for green line ( $\theta$ )	=	
Wavelength of the green line ( $\lambda_G$ )	=	$\frac{\sin \theta}{Nn}$ m =
Angle of diffraction in degrees for yellow line ( $\theta$ )	=	
Wavelength of the yellow line ( $\lambda_Y$ )	=	$\frac{\sin \theta}{Nn}$ m =
Angle of diffraction in degrees for red line ( $\theta$ )	=	
Wavelength of the red line ( $\lambda_R$ )	=	$\frac{\sin \theta}{Nn}$ m =

### Result:

1. Wavelength of the violet line ( $\lambda_V$ ) =
2. Wavelength of the blue line ( $\lambda_b$ ) =
3. Wavelength of the green line ( $\lambda_g$ ) =
4. Wavelength of the yellow line ( $\lambda_y$ ) =
5. Wavelength of the red line ( $\lambda_r$ ) =

### Outcome

At the end of this experiment, the students would be able

- To understand the principle of diffraction
- To differentiate Fraunhofer and Fresnel's diffraction
- To determine the wavelengths of prominent spectral lines of mercury spectrum

## 4. DETERMINATION OF ANGLE OF DIVERGENCE OF LASER BEAM

### Objectives

- To learn about the characteristics of lasers
- To study angle of divergence of the laser beam

### Aim

To determine the angle of divergence of laser beam using He-Ne laser and Semiconductor laser and to find out which laser is highly directional.

### Apparatus required

He-Ne laser, Semiconductor laser, optical bench, screen and ruler.

### Formula

$$\text{Angle of divergence of the laser beam, } \Phi = \frac{(a_2 - a_1)}{(d_2 - d_1)} m$$

where  $d_1$  is the distance between laser source and the screen in m

$a_1$  is the spot size of the laser beam on the screen for distance  $d_1$  in m

$d_2$  is the new distance between laser source and the screen in m

$a_2$  is the spot size of the laser beam on the screen for distance  $d_2$  in m

### Procedure

The experimental setup used to find the angle of divergence of the laser beam is shown as in fig.1.

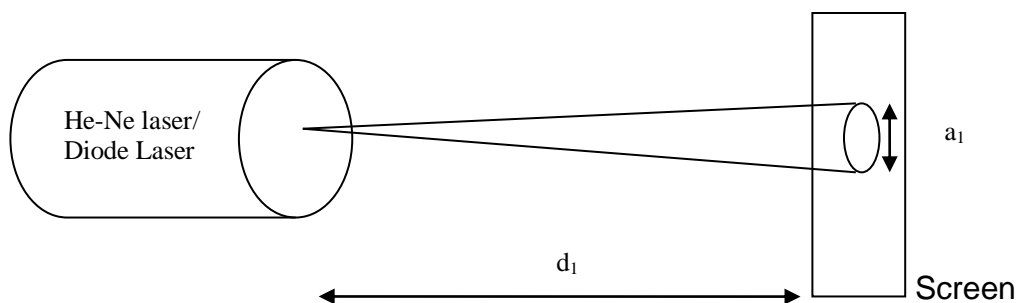

**Fig.1. Measurement of Divergence of Laser beam**

The Laser beam is allowed to fall on the screen and the spot of the beam is

observed and the spot size of the beam is measured as shown in Fig.1.

1. The laser beam from He-Ne is made to fall on the screen which is kept at a distance of  $d_1$  from the source.
2. The spot size of the beam is noted and is taken as  $a_1$ .
3. Now the position of the screen is altered to a new position  $d_2$  from the laser source and again the spot size of the beam is noted as  $a_2$ .
4. The same procedure is repeated by changing the position of the screen at equal intervals atleast 5 times.
5. The readings corresponding to the position of the screen and spot size of the beam is tabulated.
6. From this, the angle of divergence of the laser beam is calculated using the formula
 
$$\Phi = (a_2 - a_1) / (d_2 - d_1) \text{ radians}$$
7. The same is repeated by using semiconductor laser diode for the same distances as done with He-Ne laser.
8. The angle of divergence calculated was compared and the results are interpreted using two different types of laser beam.

### 1. Measurement of angle of divergence using He-Ne laser

S. No.	Distance between laser beam and screen X 10 <sup>-2</sup> m	Diameter of the spot (Horizontal) X 10 <sup>-2</sup> m	Diameter of the spot ( Vertical) X 10 <sup>-2</sup> m	Mean Diameter of the spot X 10 <sup>-2</sup> m	$\phi = (a_2 - a_1) / (d_2 - d_1)$ radians

## 2. Measurement of angle of divergence using semiconductor laser diode

S. No.	Distance between laser beam and screen $\times 10^{-2}\text{m}$	Diameter of the spot (Horizontal) $\times 10^{-2}\text{m}$	Diameter of the spot (Vertical) $\times 10^{-2}\text{m}$	Mean Diameter of the spot $\times 10^{-2}\text{m}$	$\phi = (a_2 - a_1) / (d_2 - d_1)$ radians

### Calculation

Distance between laser source and the screen ( $d_1$ ) =                  m

Spot size of the laser beam on the screen for distance  $d_1$  ( $a_1$ ) =                  m

Distance between laser source and the screen ( $d_2$ ) =                  m

Spot size of the laser beam on the screen for distance  $d_2$  ( $a_2$ ) =                  m

Angle of divergence of the laser beam,  $\Phi = (a_2 - a_1) / (d_2 - d_1)$  radians

### Result

1. Angle of divergence of the beam using He-Ne laser =
2. Angle of divergence of the beam using semiconductor laser =

### Outcome

At the end of the experiment, the students would be able

- To understand the importance of laser beam compared to ordinary light
- To determine the angle of divergence of the laser beam
- To understand the applications of Lasers in Engineering and Medical fields

## 5. DETERMINATION OF PARTICLE SIZE OF LYCOPODIM POWDER USING SEMICONDUCTOR LASER

### Objectives

- To determine the concept of diffraction
- To determine the size of particles using the given Laser source
- To learn about the characteristics of Lasers
- To study the various types of Lasers

### Aim

To determine the particle size of microparticles (lycopodium powder) using laser diffracting grating.

### Apparatus Required

Laser source , Fine micro particles having nearly same size (say Lycopodium powder), Glass plate, Screen, and a Metre Scale.

### Formula

*Size of the microparticle using laser diffraction grating,  $2d = \frac{n\lambda D}{x_n} m$*

where n is the order of diffraction

$\lambda$  is the wave length of laser light used in m (690 nm)

D is the distance between the glass plate and the screen in m

$x_n$  is the distance between the central bright spot and the n<sup>th</sup> fringe in m.

### Procedure

When LASER is passed through a glass plate spread with fine micro particles, the beam gets diffracted by the particles and circular rings are obtained on the screen as shown in Fig. 1. By measuring the radii of the rings and the distance between the glass plate and the screen, the size of the particle can be determined.

1. Sprinkle the fine micro particles (Lycopodium ) on the glass plate.
2. Mount the LASER source on a stand
3. Place a screen in front of the LASER source at some distance
4. Mount the glass plate on a separate stand and place it between the LASER source and the screen.
5. Switch ON the laser source and allow the beam to pass through the glass plate.
6. Adjust the distance (D) between the glass plate and the screen to get a clear circular fringe pattern (diffraction pattern) on the screen. The intensity is found to decrease from zeroth order (central spot) to higher orders.
7. Measure the distance (D) between the glass plate and the screen using metre scale.
8. Measure the distance ( $x_n$ ) of the first order, second order and so on from the central bright spot (radii of the rings).
9. Repeat the experiment by varying the distance (D) between the glass plate and the screen and the readings are tabulated.



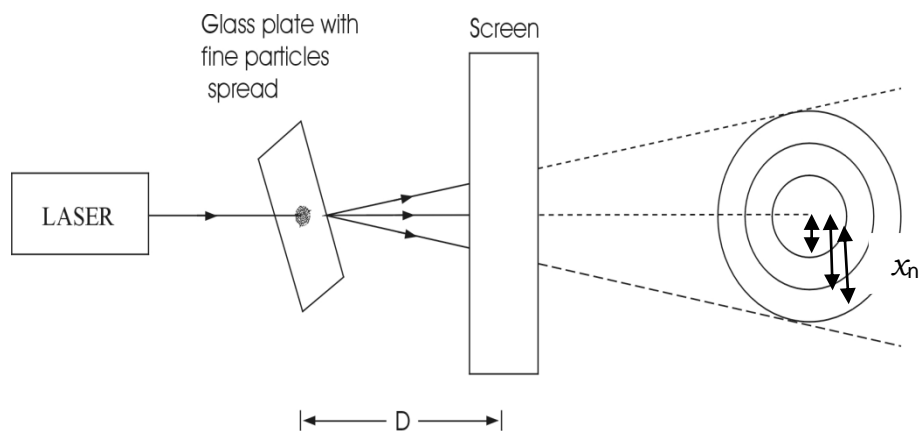

**Fig. 1.**

**To determine the particle size**

S. No.	Distance between the screen and the glass plate ( $D$ ) $\times 10^{-2}$ m	Order of diffraction $n$	Distance between the central bright and $n^{\text{th}}$ fringe ( $x_n$ ) $\times 10^{-2}$ m	Particle size $2d$ $\times 10^{-5}$ m
1	1			
	2			
	3			
2	1			
	2			
	3			
3	1			
	2			
	3			

Mean  $2d = \text{-----}$

**Calculation:**

Order of diffraction (n)	=	
Wave length of laser light ( $\lambda$ )	=	m
Distance between the glass plate and the screen (D)	=	m
Distance between the central bright spot and the n <sup>th</sup> fringe ( $x_n$ )	=	m

The size of the microparticle using laser diffraction grating,  $2d = \frac{n\lambda D}{x_n}$

**Result**

The size of the microparticle using laser diffraction grating,  $2d =$

**Outcome**

At the end of the experiment, the students would be able

- To determine the size of particles using the given Laser source
- To understand the importance of laser beam compared to ordinary light
- To provide the use of Lasers for different applications
- To understand the applications of Lasers in Engineering and Medical fields
- To get the depth in knowledge about the Lasers and its applications in various fields

**Precautions :**

It is dangerous to view the laser light directly. So direct exposure of eye to laser light should be avoided.

## 6. DETERMINATION OF WAVELENGTH OF LASER LIGHT USING DIFFRACTION GRATING

### Objectives

- To determine the concept of diffraction
- To determine the wavelength of the given Laser source
- To learn about the characteristics of Lasers
- To study the various types of Lasers

### Aim

To determine the wavelength of the laser light using diffraction grating.

### Apparatus required

Spectrometer, Diffraction grating, He-Ne laser or Semiconductor laser, optical bench and screen or scale arrangement.

### Formula

$$\text{Wavelength of laser light, } \lambda = \frac{\sin\theta}{nN} m$$

where

$\theta = \tan^{-1} (x_n / l)$  is the angle of diffraction

N is the number of lines per metre in the grating in lines/m

$x_n$  is the distance of the spot from the central maximum in m

l is the perpendicular distance between grating and the scale in m

n is the order of the spectrum

### Procedure

The laser is mounted on its saddle on the optical bench. The grating is mounted on an upright next to laser. The screen or scale arrangement is placed next to the grating as shown in Fig .1. The laser is switched on. The relative orientation of laser with respect to grating is adjusted such that spectral

spots are observed on the scale. The scale is moved towards and away from the grating till at least three (for 7500 lines/inch) spots are clearly seen on the scale on the either side of the central spot. The central maximum and other maxima corresponding to different orders of the spectrum on either side of the central maximum are identified. The scale is again adjusted in such a way that the central spot coincides with the zero in the scale. Now the distances ( $x_n$ ) of the spots corresponding to first order, second order etc on either side of central maximum are noted. The distance between the grating and the scale ( $l$ ) is measured. The readings are tabulated.

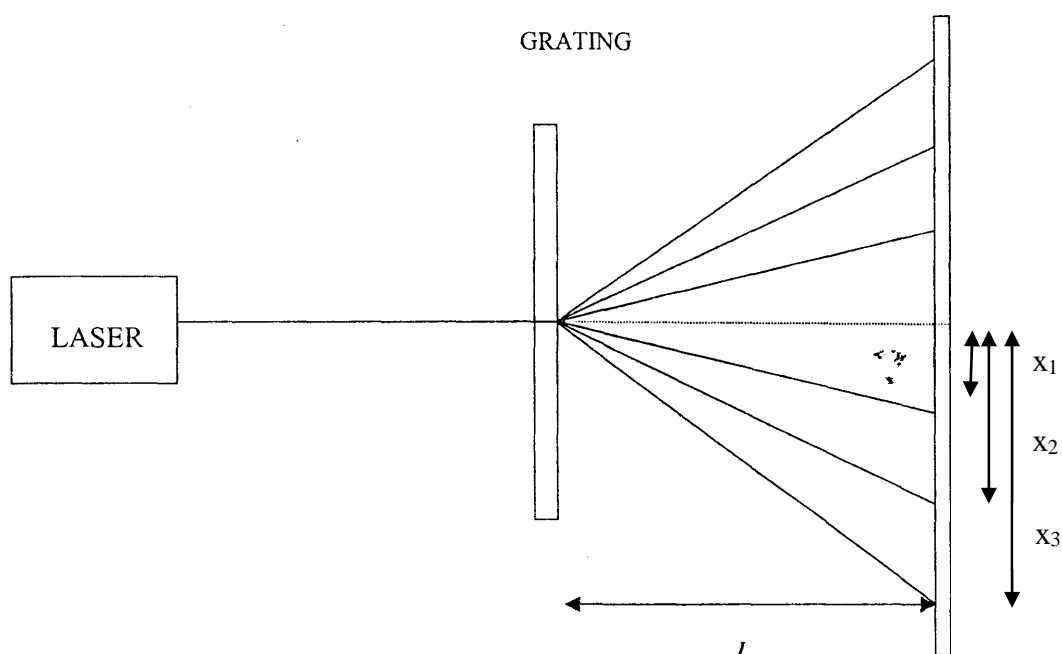

**Fig. 1. Experimental Setup**

The experiment is repeated for at least three  $P$  values (15cm, 20cm & 25cm). The value of  $x_n$  is calculated for each case using the formula  $\theta = \tan^{-1}(x_n / l)$ .

Knowing the values of  $\theta$ ,  $n$  &  $N$ , the wavelength of laser light can be calculated using the formula  $\lambda = \text{Sin}\theta / n N$

**To find  $\lambda$** 

S. No.	Order n	l cm	$x_n$ cm			$\theta = \tan^{-1}(x_n/l)$	Sin $\theta$	$\lambda$ m
			LHS	RHS	Mean			
1	1							
2	2							
3	3							
4	1							
5	2							
6	3							
7	1							
8	2							
9	3							

Mean value of  $\lambda = m$ .

**Calculation**

Distance of the spot from the central maximum ( $x_n$ ) = m

Perpendicular distance between grating & the scale (l) = m

Number of lines per metre in the grating (N) = lines/m

Angle of diffraction,  $\theta = \tan^{-1}(x_n / l)$  =

Wavelength of laser light,  $\lambda = \text{Sin}\theta / n N$

**Result**

Wavelength of laser light,  $\lambda =$

**Outcome**

At the end of the experiment, the students would be able

- To determine the wavelength of the given Laser source
- To understand the importance of laser beam compared to ordinary light
- To provide the use of Lasers for different applications
- To understand the applications of Lasers in Engineering and Medical fields
- To get the depth in knowledge about the Lasers and its applications in various fields

## 7. NUMERICAL APERTURE AND ACCEPTANCE ANGLE OF AN OPTICAL FIBRE

### Objectives

- To understand the basics of light propagation using fibre optic cable
- To understand the Numerical aperture and acceptance angle of the fibre.

### AIM

To determine the acceptance angle and numerical aperture of the given fibre optic cable.

### APPARATUS REQUIRED

Diode laser source, fibre optic cable (typically 1 m ) and NA

### FORMULA

*1. Numerical aperture of the given optical fibre,  $NA = \sin\theta_{max}$*

$$NA = \frac{D}{(4L^2 + D^2)^{1/2}}$$

*2. Acceptance angle of the given optical fibre,  $\theta_{max} = \sin^{-1}(NA)$*

where  $\theta_{max}$  is the acceptance angle of the fibre

D is the diameter of the laser spot noted on the screen in meter

L is the distance of the screen from the fibre end

### PROCEDURE :

#### Measurement of numerical aperture and acceptance angle:

Numerical aperture of any optical system is a measure of how much light can be collected by the optical system. It is the product of the refractive index of the

incident medium and the sine of the maximum ray angle. The schematic diagram of the numerical aperture measurement system is shown in the figure.

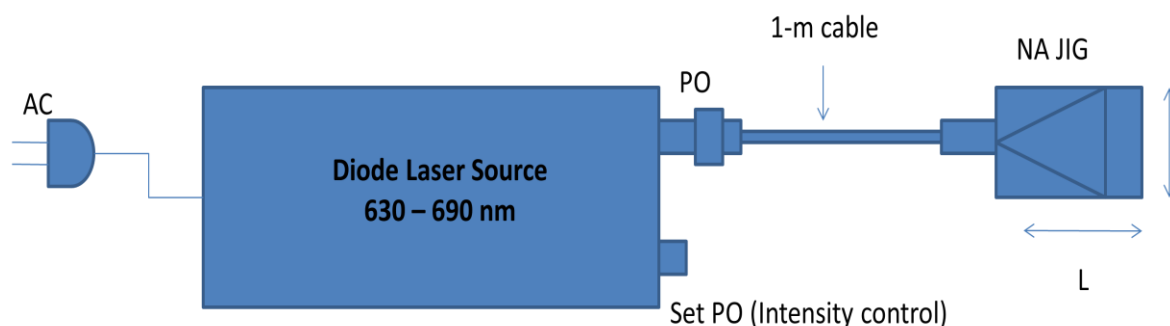

**Figure : Set up for NA measurement**

One end of the 1 – metre optical fibre cable is connected to PO of source and the other end to the NA JIG as shown in the figure. The AC main is switched on. Light should appear at the end of the fibre on the NA JIG. Turn the set Po knob clockwise to set to maximum intensity.

The white screen in the NA JIG with the 4 concentric circles each of 10, 15 20, and 25 mm in diameter is kept vertically at a suitable distance so that the red spot from the emitting fibre coincides with the smallest (10mm) circle. The circumference of the spot outermost must coincide with the circle. A dark room will facilitate good contrast. The distance of the screen from the fibre end  $L$  and the diameter of the spot are noted. The diameter of the circle is measured accurately with a suitable scale which is provided in the JIG itself. The experiment is repeated for 15 mm, 20 mm, and 25 mm diameters in the same way. The readings are tabulated.

Then the numerical aperture of the optical fibre system is computed using the formula,

$$NA = \mu_0 \sin\theta_{\max} = \frac{D}{(4L^2 + D^2)^{1/2}}$$



where  $\mu_0$  is the refractive index of the medium. For air  $\mu_0=1$ , hence  $NA = \sin\theta_{\max}$  and  $\theta_{\max}$  is the acceptance ( maximum-ray ) angle of the fibre.

Acceptance angle of the optical fibre

$$\theta_{\max} = \sin^{-1}(NA)$$

Note :

The intensity of the spot will not be evenly distributed if there are twists on the fibre. So, the twists must be checked and removed before taking measurement.

### Measurement of Numerical aperture

Sl.No.	Distance of the spot from fibre end (L) in $10^{-3}\text{m}$	Diameter of spot in $10^{-3}\text{m}$	$NA = \frac{D}{(4L^2+D^2)^{1/2}}$	$\theta_{\max} = \sin^{-1}(NA)$

### Calculation

Distance of the spot from the fibre end (L) =  $10^{-3}\text{m}$

Diameter of the spot =  $10^{-3}\text{m}$

Numerical Aperture (NA) =  $\frac{D}{(4L^2+D^2)^{1/2}}$   
=

Acceptance angle of the fibre ( $\theta_{\max}$ ) =  $\sin^{-1}(NA)$

**RESULT :**

1. Numerical aperture of the given fibre optic cable =
2. Acceptance angle of the fibre =

**Outcome**

At the end of this class, the students will be able :

- To determine the acceptance angle of the fibre
- To find out and compare the NA of the different optical fibres.

## 8. DETERMINATION OF THERMAL CONDUCTIVITY OF A BAD CONDUCTOR BY LEE'S DISC METHOD

### Objectives

- To know about different modes of heat transfer, via conduction, convection and radiation
- To understand the principle of Lee's disc experiment
- To determine the coefficient of thermal conductivity of a bad conductor using Lee's disc
- To understand the heat loss with respect to dimensions of good conductor & bad conductor

### Aim

To determine the thermal conductivity of a bad conductor by lee's disc method

### Apparatus required

Lee's disc apparatus, Bad conductor (thin cardboard or glass disc of uniform thickness) , Two thermometers, Steam boiler, Heater, Stop watch, Screw gauge, Vernier caliper, Balance.

### Formula

**Thermal conductivity of a bad conductor,  $K = \frac{Msd (r + 2h) \left(\frac{d\theta}{dt}\right)_{\theta_2}}{\pi r^2 (\theta_1 - \theta_2) (2r + h)} \text{ W/m/k}$**

where M - mass of the metal disc in kg

S – specific heat capacity of the material of the disc in  $\text{Jkg}^{-1} \text{K}^{-1}$

d – thickness of a bad conductor in m

r – radius of the metallic disc in m

h – thickness of the metal disc in m

$\theta_1$  – steady state temperature of the steam chamber in  $^{\circ}\text{C}$

$\theta_2$  - steady state temperature of the metal disc in  $^{\circ}\text{C}$

$\left(\frac{d\theta}{dt}\right)_{\theta_2}$  - rate of cooling at steady state temperature  $\theta_2$  in  $^{\circ}\text{Cs}^{-1}$

## Procedure

Lee's disc apparatus is shown in Fig.1. It consists of a highly polished brass disc B. It is suspended by three strings from a circular ring R which is fixed to an iron stand. A circular cardboard whose diameter is the same as that of the disc is placed on the disc and over it is placed a steam chamber S. The steam chamber is also circular in shape having the same diameter as that of the disc. Holes are provided in B and S to facilitate the insertion of thermometers  $T_1$  and  $T_2$ .

Steam is allowed to pass through the chamber as shown in the Fig.1. The temperatures indicated by the two thermometers will start rising. After about half an hour, a steady state is reached when the temperature of the lower disc no longer rises. At this stage, find the temperature  $\theta_2$  °C of the lower disc. Let the temperature of the steam as indicated by the thermometer in the upper chamber be  $\theta_1$  °C.

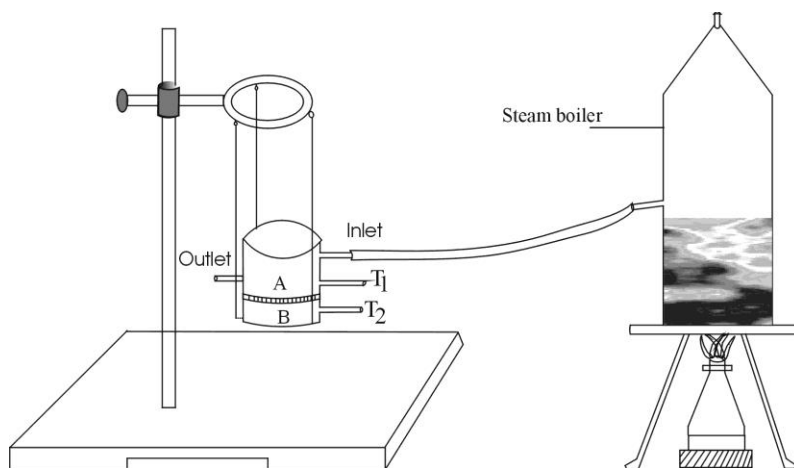

**Fig.1 Lee's disc arrangement**

Now, the cardboard is removed by gently lifting the upper chamber. The lower disc is allowed to be heated directly by keeping it in contact with the steam chamber. When the temperature of the lower disc attains a value of the about 10 more than its steady state temperature, the chamber is removed and the lower disc is allowed to cool down on its own accord. The time- temperature



### To find the diameter of the metallic disc (D)

L. C. = 0.01 cm

S.No.	M.S.R cm	V.S.C div	V.S.R cm	T. R.= MSR+ V.S.R cm
1				
2				
3				
4				
5				
				Mean (D) = ..... x 10 <sup>-2</sup> m

Mean radius of the metallic disc (r) = D/2 = ..... x 10<sup>-2</sup> m

### To find the thickness of the card board (d)

L.C. = 0.01 mm

Zero error = .....div

Zero correction = ±..... mm

S.No.	P.S.R mm	H.S.C	H.S.R	Total Reading = PSR+ (HSC X LC) mm	Corrected Reading = T.R. ± Z.C. mm
1					
2					
3					
4					
5					
					Mean (d) = ..... x 10 <sup>-3</sup> m

### To find the thickness of the metallic disc (h)

L.C. = 0.01 mm

Zero error = -----div

Zero correction =  $\pm$ ----- mm

S.No.	PSR mm	HSC div	Observed Reading = PSR+ (HSC X LC) mm	Correct Reading = O.R $\pm$ Z.C. mm
	Mean (h) = ----- x 10 <sup>-3</sup> m			

Graph :

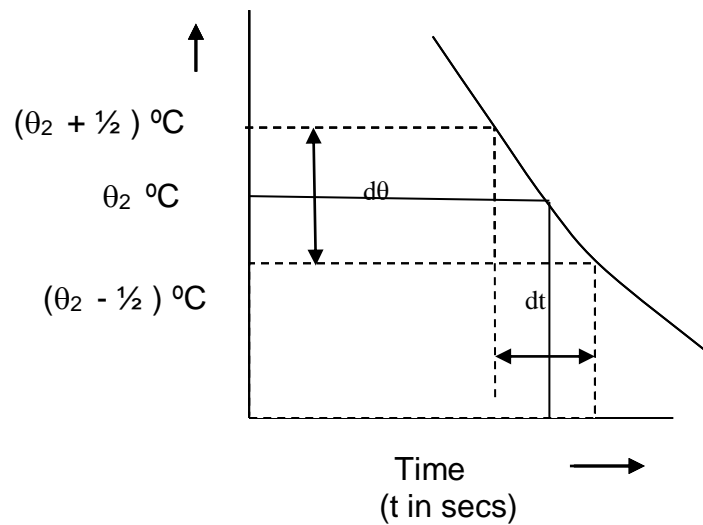

Fig. 2

### Calculations

Mass of the lower disc by a berranger balance , M = kg

Specific heat capacity of the materials of the disc, S = J kg<sup>-1</sup>k<sup>-1</sup>

Radius of the lower metallic disc, r = m

Thickness of the lower metallic disc, h = m

Thickness of the card board, d	=	m
Steady temperature of the steam chamber, $\theta_2$	=	$^{\circ}\text{C}$
Steady temperature of the disc, $\theta_1$	=	$^{\circ}\text{C}$
Rate of cooling $\left(\frac{d\theta}{dt}\right)_{\theta_2}$ at steady temperature $\theta_2$ $^{\circ}\text{C}$	=	$^{\circ}\text{C/s}$

**Result :**

Thermal conductivity of the bad conductor using Lee's disc method =

**Outcome**

At the end of this experiment, the students would be able

- To know about differentiate the different modes of heat transfer
- To understand the principle of Lee's disc experiment
- To determine the coefficient of thermal conductivity of a bad conductor using Lee's disc
- To understand the difference in heat loss in good conductor & bad conductor



## **VIVA VOCE QUESTIONS AND ANSWERS**

### **1. DETERMINATION OF VELOCITY OF ULTRASONIC WAVES IN A GIVEN LIQUID USING ULTRASONIC INTERFEROMETER.**

1. What are ultrasonics?

Ultrasonics are sound waves having frequency more than 20,000 Hz. These sound waves are inaudible to human ear.

2. What is piezo electric effect?

When two pair of opposite sides of a Quartz crystal is applied with mechanical stress, then in other two pair of opposite sides electric charges are induced. This phenomenon is called piezo electric effect.

3. What is resonance condition to produce Ultrasonic waves in a piezo electric oscillator?

The resonance is condition is that the natural frequency of vibration of Quartz must be matched with frequency of oscillatory tank circuit.

### **2. DETERMINATION OF THICKNESS OF A THIN WIRE USING AIR WEDGE METHOD**

1. What is an Air wedge?

Two plane glass plates inclined at a small angle forming a wedge shaped air film between them is called an Air wedge.

2. What is the principle of physics involved in this experiment?

Interference of light waves reflected from first and second glass plates of air wedge is the principle of physics involved.

3. What are the conditions for the light rays to obtain interference pattern?

Two light rays from coherent source should undergo superimposition with a constant path difference between them.

4. What are the uses of Air wedge?

Using Air wedge experiment, we can determine the thickness of very thin materials where conventional measuring instruments like screw gauge or vernier calipers cannot be used.

5. What is Fringe width?

The distance between any two consecutive dark or bright fringes is called fringe width.

6. What are coherent sources?

Two sources are said to be coherent if they have same frequency, same amplitude and are in same phase with each other.

### **3. DETERMINATION OF WAVELENGTH OF LIGHT USING SPECTROMETER DIFFRACTION GRATING**

1. What is plane transmission grating?

It is an optically plane glass plate on which very fine equidistant close lines or grooves are made by ruling using diamond point.

2. What is the principle of physics involved in this experiment?

The diffraction of light rays at the grating element when light rays are incident on it is the principle in the experiment.

3. What is diffraction?

The bending of light rays when they pass through an opening or about an obstacle is called diffraction.

4. What is called Standardization of Grating?

The process of determining the number of lines or grooves per meter incorporated or drawn on the grating element in a Spectrometer experiment using a source whose wavelength is known is called Standardization of grating.

### **4. DETERMINATION OF ANGLE OF DIVERGENCE OF LASER BEAM**

1. What are the characteristics of Laser

Lasers are highly coherent, highly intense, highly monochromatic and highly

directional beam of light.

2. What is stimulated emission?

A photon have energy  $E$  equal to the difference in the energy between two levels, stimulate an atom in the higher energy state to make a transition to the lower energy state with the creation of a second photon is called stimulated emission.

3. Compare the angular spread in a laser beam with an ordinary light?

The light beam can travel as a parallel beam upto a distance of  $d^2/\lambda$  where  $d$  is the diameter of the aperture through which the light is passing and  $\lambda$  is the wavelength of the light beam. After travelling the distance of  $d^2/\lambda$ , the light beam spreads radially. The angular spread is given by  $\Delta\theta = \lambda/d$ . For laser beam, the angular spread is 1mm per 1m while for an ordinary light, it is 1m per 1m. This shows that laser beam is highly directional compared to ordinary light.

## **5. DETERMINATION OF PARTICLE SIZE OF LYCOPODIUM POWDER USING SEMICONDUCTOR LASER**

1. What is the principle involved in this experiment.

Diffraction of laser light at the grating element is the principle in this experiment.

2. What is the diffraction pattern observed on the screen in particle size experiment?

In particle size experiment, concentric rings are observed as interference pattern with a central maximum.

3. What are the characteristics of Laser?

Lasers are highly coherent, highly intense, highly monochromatic and highly directional beam of light.

## **6. DETERMINATION OF WAVELENGTH OF LASER LIGHT USING SEMICONDUCTOR LASER DIFFRACTION**

1. What are the characteristics of Laser?

Lasers are highly coherent, highly intense, highly monochromatic and highly directional beam of light.

2. What is population Inversion?

If the number of atoms in the excited state is greater than the number of atoms in the ground state, it is called as population inversion.

3. What are the different pumping mechanisms in laser?

Optical pumping, electric discharge method, Inelastic atom-atom collision, direct conversion and chemical pumping.

## **7. DETERMINATION OF ACCEPTANCE ANGLE AND NUMERICAL APERTURE USING FIBER OPTIC CABLE**

1. What is the principle of fibre optic communication?

The total internal reflection of light rays along the length of the fibre is the principle in light s propagation in fibre optical communication.

2. What is Numerical Aperture?

Numerical Aperture (NA) is a measure of how much light can be collected by an optical system such as an optical fibre or a microscope lens. The NA is related to the acceptance angle  $\theta_a$ , which indicates the size of a cone of light that can be accepted by the fibre.

3. What is Acceptance angle?

It is the maximum angle that a light ray can make at the face of the optical fibre during entry which allows it to suffer total internal reflection along the length of the fibre.

## 8. DETERMINATION OF THERMAL CONDUCTIVITY OF A BAD CONDUCTOR BY LEE'S DISC METHOD

1. What is Conduction?

Conduction is a process in which heat is transferred from the hotter end to colder end without the actual motion of particles.

2. What is Thermal conductivity?

It is the property of material to conduct heat. It is defined as the amount of heat conducted through a conductor of unit area of cross section in unit time when the opposite faces of it are maintained at 1 kelvin.

3. What are static and dynamic parts of Lee's disc experiment?

**Static part:** During the first half an hour of experiment, the steam passes through the chamber and the temperature in thermometers  $T_1$  and  $T_2$  will reach a steady state ( $T_1 > T_2$ ).

**Dynamic Part:** In this part, the poor conductor is removed and Lees disc is kept in direct contact with steam chamber and temperature of disc rises. When this temperature comes to about 10 degrees above  $T_2$ , then steam chamber is removed and the disc is allowed to cool. The temperature fall is noted with respect to time.

4. What is the use of Lee's disc experiment?

Using this experiment of Lee's disc, we can determine the thermal conductivity of various poor conductors and compare them with the available standard values.

5. Can we use Lee's disc experiment to determine the thermal conductivity of good conductors?

No, Experiment like Forbes method is used to determine thermal conductivity of good conductors.